

**MW9076 Series**  
**Optical Time Domain Reflectometer**  
**Operation Manual**

**19th Edition**

**For safety and warning information, please read this manual before attempting to use the equipment.  
Keep this manual with the equipment.**

**ANRITSU CORPORATION**

# Safety Symbols

To prevent the risk of personal injury or loss related to equipment malfunction, Anritsu Corporation uses the following safety symbols to indicate safety-related information. Ensure that you clearly understand the meanings of the symbols BEFORE using the equipment. Some or all of the following symbols may be used on all Anritsu equipment. In addition, there may be other labels attached to products that are not shown in the diagrams in this manual.

## Symbols used in manual

**DANGER**  This indicates a very dangerous procedure that could result in serious injury or death if not performed properly.

**WARNING**  This indicates a hazardous procedure that could result in serious injury or death if not performed properly.

**CAUTION**  This indicates a hazardous procedure or danger that could result in light-to-severe injury, or loss related to equipment malfunction, if proper precautions are not taken.

## Safety Symbols Used on Equipment and in Manual

The following safety symbols are used inside or on the equipment near operation locations to provide information about safety items and operation precautions. Ensure that you clearly understand the meanings of the symbols and take the necessary precautions BEFORE using the equipment.



This indicates a prohibited operation. The prohibited operation is indicated symbolically in or near the barred circle.



This indicates an obligatory safety precaution. The obligatory operation is indicated symbolically in or near the circle.



This indicates a warning or caution. The contents are indicated symbolically in or near the triangle.



This indicates a note. The contents are described in the box.



These indicate that the marked part should be recycled.

MW9076 Series  
Optical Time Domain Reflectometer  
Operation Manual

25 August 1999 (First Edition)  
26 December 2008 (19th Edition)

Copyright © 1999-2008, ANRITSU CORPORATION.

All rights reserved. No part of this manual may be reproduced without the prior written permission of the publisher.

The contents of this manual may be changed without prior notice.

Printed in Japan

# For Safety



## DANGER

NEVER touch parts where the label shown on the left is attached. Such parts have high voltages of at least 1 kV and there is a risk of receiving a fatal electric shock.



## WARNING

1. ALWAYS refer to the operation manual when working near locations at which the alert mark shown on the left is attached. If the advice in the operation manual is not followed there is a risk of personal injury or reduced equipment performance. The alert mark shown on the left may also be used with other marks and descriptions to indicate other dangers.

### 2. IEC 61010 Standard

The IEC 61010 standard specifies four categories to ensure that an instrument is used only at locations where it is safe to make measurements. This instrument is designed for measurement category I (CAT I). DO NOT use this instrument at locations specified as category II, III, or IV as defined below.

Measurement category I (CAT I):

Secondary circuits of a device that is not directly connected to a power outlet.

Measurement category II (CAT II):

Primary circuits of a device that is directly connected to a power outlet, e.g., portable tools or home appliance.

Measurement category III (CAT III):

Primary circuits of a device (fixed equipment) to which power is supplied directly from the distribution panel, and circuits running from the distribution panel to power outlet.

Measurement category IV (CAT IV):

Building service-line entrance circuits, and circuits running from the service-line entrance to the meter or primary circuit breaker (distribution panel).

# For Safety

## WARNING

### Electric Shock

### Repair

WARNING 

### Calibration



### Falling Over

### Replacing Battery



3. Laser radiation warning
  - NEVER look directly into the cable connector on the equipment nor into the end of a cable connected to the equipment. There is a risk of injury if laser radiation enters the eye.
  - The Laser Safety label is attached to the equipment for safety use as indicated in "Laser Safety" later in this section.
4. To ensure that the instrument is earthed, always use the supplied 3-pin power cord, and insert the plug into an outlet with an earth terminal. If power is supplied without earthing the equipment, there is a risk of receiving a severe or fatal electric shock or causing damage to the internal components.
5. This equipment cannot be repaired by the operator. DO NOT attempt to remove the equipment covers or unit covers or to disassemble internal components. Only qualified service personnel with a knowledge of electrical fire and shock hazards should service this equipment. There are high-voltage parts in this equipment presenting a risk of severe injury or fatal electric shock to untrained personnel. In addition, there is a risk of damage to precision components.
6. The performance-guarantee seal verifies the integrity of the equipment. To ensure the continued integrity of the equipment, only Anritsu service personnel, or service personnel of an Anritsu sales representative, should break this seal to repair or calibrate the equipment. If the performance-guarantee seal is broken by you or a third party, the performance of the equipment cannot be guaranteed.
7. This equipment should always be positioned in the correct manner. If the cabinet is turned on its side, etc., it will be unstable and may be damaged if it falls over as a result of receiving a slight mechanical shock.  
Always set up the equipment in a position where the power switch can be reached without difficulty.
8. When replacing the battery, use the specified battery and insert it with the correct polarity. If the wrong battery is used, or if the battery is inserted with reversed polarity, there is a risk of explosion causing severe injury or death.

# For Safety

## WARNING

### Battery Fluid

9. DO NOT short the battery terminals and never attempt to disassemble the battery or dispose of it in a fire. If the battery is damaged by any of these actions, the battery fluid may leak. This fluid is poisonous.

DO NOT touch the battery fluid, ingest it, or get in your eyes. If it is accidentally ingested, spit it out immediately, rinse your mouth with water and seek medical help. If it enters your eyes accidentally, do not rub your eyes, rinse them with clean running water and seek medical help. If the liquid gets on your skin or clothes, wash it off carefully and thoroughly.

### LCD

10. This instrument uses a Liquid Crystal Display (LCD). DO NOT subject the instrument to excessive force or drop it. If the LCD is subjected to strong mechanical shock, it may break and liquid may leak.

This liquid is very caustic and poisonous.

DO NOT touch it, ingest it, or get in your eyes. If it is ingested accidentally, spit it out immediately, rinse your mouth with water and seek medical help. If it enters your eyes accidentally, do not rub your eyes, rinse them with clean running water and seek medical help. If the liquid gets on your skin or clothes, wash it off carefully and thoroughly.

# For Safety

## WARNING

### Laser Safety

Before using this instrument, always ensure that the warning light is lit when the optical output switch is turned on. If this warning light does not turn on, the equipment may be faulty and for safety reasons should be returned to an Anritsu service center or representative for repair.

Optical units for MW9076 Series Optical Time Domain Reflectometer have Class 1, 1M laser emitting parts as specified in IEC 60825-1, or Class I, II parts as specified in 21 CFR 1040.10 (Refer to Table 1). The explanatory labels shown on “Laser Radiation Markings” are attached

Never use optical instruments to directly view Class 1M laser products. Doing so may result in serious damage to the eyes.

Table 1

Kind of Light Source	Standard Name	
	IEC 60825-1	21 CFR 1040.10
OTDR light source	Class 1	Class I
Visible LD light source	Class 1M	Class II

## CAUTION

Use of controls or adjustments or performance of procedures other than those specified herein may result in hazardous radiation exposure.

The use of optical instruments with this product will increase eye hazard.

# For Safety

Class 1, 1M indicate the danger degree of the laser radiation specified below according to IEC 60825-1.

Class 1: Lasers that are safe under reasonably foreseeable conditions of operation, including the use of optical instruments for intrabeam viewing.

Class 1M: Lasers emitting in the wavelength range from 302.5 to 4000 nm that are safe under reasonably foreseeable conditions of operation, but may be hazardous if the user employs optics within the beam. Two conditions apply:

- a) for diverging beams, if the user views the laser output with certain optical instruments (for example, eye loupes, magnifiers and microscopes ) within a distance of 100 mn ;  
or
- b) for collimated beams, if the user views the laser output with certain optical instruments ( for example , telescopes and binoculars ).

And, Class I, IIa, II indicate the degree of danger of the laser radiation outlined below as defined by 21 CFR 1040.10.

Class I: Class I labels of laser radiation are not considered to be hazardous.

Class IIa: Class IIa labels of laser radiation are not considered to be hazardous if viewed for any period of time less than or equal to  $1 \times 10^3$  seconds but are considered to be a chronic viewing hazard for any period of time greater than  $1 \times 10^3$  seconds. The wavelength range of laser radiating is in 400 to 710 nm.

Class II: Class II labels of laser radiation are considered to be a chronic viewing hazard. The wavelength range of laser radiating is in 400 to 710 nm.

---

# For Safety

## Laser Radiation Markings

(Attached when visible LD light source installed)



FDA (Attached when visible LD light source installed and only for exportation to the United States of America)

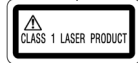
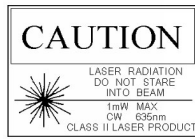

AVOID EXPOSURE- Visible Laser radiation is emitted from this aperture

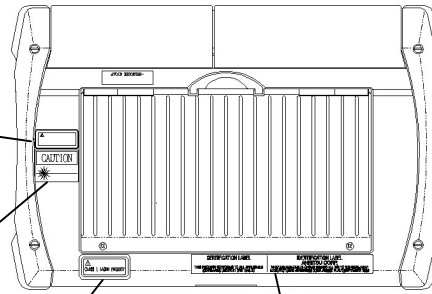

FDA (Attached when visible LD light source installed and only for exportation to the United States of America)



FDA (Attached only for exportation to the United States of America)



# For Safety

## CAUTION

### **Replacing Memory Back-up Battery**

This equipment uses a Poly-carbomonofluoride lithium battery to backup the memory. This battery must be replaced by service personnel when it has reached the end of its useful life; contact the Anritsu sales section or your nearest representative.

Note: The battery used in this equipment has a maximum useful life of 7 years. It should be replaced before this period has elapsed.

### **External Storage Media**

This equipment uses memory cards as external storage media for storing data and programs.

If this media is mishandled or becomes faulty, important data may be lost. To prevent this chance occurrence, all important data and programs should be backed-up.

Anritsu will not be held responsible for lost data.

Pay careful attention to the following points.

- Never remove the memory card from the pulse tester while it is being accessed.
- The memory card may be damaged by static electric charges.
- Anritsu has thoroughly tested all external storage media shipped with this instrument. Users should note that external storage media not shipped with this instrument may not have been tested by Anritsu, thus Anritsu cannot guarantee the performance or suitability of such media.

### **Floppy Disk**

Do not place in a dusty area.

Clean the magnetic head periodically to ensure normal operation.

Refer to the section on cleaning the head later in this manual.

### **Use in a residential environment**

This instrument is designed for an industrial environment.

In a residential environment this instrument may cause radio interference in which case the user may be required to take adequate measures.

## **Equipment Certificate**

Anritsu Corporation certifies that this equipment was tested before shipment using calibrated measuring instruments with direct traceability to public testing organizations recognized by national research laboratories, including the National Institute of Advanced Industrial Science and Technology, and the National Institute of Information and Communications Technology, and was found to meet the published specifications.

## **Anritsu Warranty**

Anritsu Corporation will repair this equipment free-of-charge if a malfunction occurs within one year after shipment due to a manufacturing fault, under the condition that this warranty is void when:

- The fault is outside the scope of the warranty conditions described in the operation manual.
- The fault is due to mishandling, misuse, or unauthorized modification or repair of the equipment by the customer.
- The fault is due to severe usage clearly exceeding normal usage.
- The fault is due to improper or insufficient maintenance by the customer.
- The fault is due to natural disaster including fire, flooding, earthquake, etc.
- The fault is due to use of non-specified peripheral equipment, peripheral parts, consumables, etc.
- The fault is due to use of a non-specified power supply or in a non-specified installation location.

In addition, this warranty is valid only for the original equipment purchaser. It is not transferable if the equipment is resold.

Anritsu Corporation shall assume no liability for injury or financial loss of the customer due to the use of or a failure to be able to use this equipment.

## **Anritsu Corporation Contact**

In the event that this equipment malfunctions, contact an Anritsu Service and Sales office. Contact information can be found on the last page of the printed version of this manual, and is available in a separate file on the CD version.

## Notes On Export Management

---

This product and its manuals may require an Export License/Approval by the Government of the product's country of origin for re-export from your country.

Before re-exporting the product or manuals, please contact us to confirm whether they are export-controlled items or not.

When you dispose of export-controlled items, the products/manuals need to be broken/shredded so as not to be unlawfully used for military purpose.

## Disposal Procedure

---

The product that you have purchased contains a rechargeable battery. The battery is recyclable. At the end of its useful life, under various state and local laws, it may be illegal to dispose of this battery into the municipal waste stream. Check with your local solid waste officials for details in your area for recycling options or proper disposal.

## Lifetime of Parts

---

The life span of certain parts used in this instrument is determined by the operating time or the power-on time. Due consideration should be given to the life spans of these parts when performing continuous operation over an extended period. These parts must be replaced at the customer's expense even if within the guaranteed period described in Warranty at the beginning of this manual. For details on life span, refer to the corresponding section in this manual.

## **Crossed-out Wheeled Bin Symbol**

Equipment marked with the Crossed-out Wheeled Bin Symbol complies with council directive 2002/96/EC (the “WEEE Directive”) in European Union.



For Products placed on the EU market after August 13, 2005, please contact your local Anritsu representative at the end of the product's useful life to arrange disposal in accordance with your initial contract and the local law.

# CE Conformity Marking

Anritsu affixes the CE Conformity marking on the following product(s) in accordance with the Council Directive 93/68/EEC to indicate that they conform to the EMC and LVD directive of the European Union (EU).

## CE marking



### 1. Product Model

Model: MW9076xx Optical Time Domain Reflectometer

### 2. Applied Directive

EMC: Council Directive 2004/108/EC

LVD: Council Directive 2006/95/EC

### 3. Applied Standards

- EMC: Emission: EN 61326-1: 2006 (Class A)  
Immunity: EN 61326-1: 2006 (Table 2)

	Performance Criteria*
IEC 61000-4-2 (ESD)	B
IEC 61000-4-3 (EMF)	A
IEC 61000-4-4 (Burst)	B
IEC 61000-4-5 (Surge)	B
IEC 61000-4-6 (CRF)	A
IEC 61000-4-11 (V dip/short)	B, C

\*: Performance Criteria

- A: During testing normal performance within the specification limits.
- B: During testing temporary degradation, or loss of function or performance which is self-recovering.
- C: During testing, temporary degradation, or loss of function or performance which requires operator intervention or system reset occurs.

Harmonic current emissions:

EN 61000-3-2: 2006 (Class A equipment)

: No limits apply for this equipment with an active input power under 75 W.

- LVD: EN 61010-1: 2001 (Pollution Degree 2)

#### **4. Authorized representative**

Name: Loic Metais  
European Quality Manager  
ANRITSU S.A. France  
Address, city: 16/18 Avenue du Quebec SILIC 720 Zone de  
Courtaboeuf  
91951 Les Ulis Cedex  
Country: France

# C-Tick Conformity Marking

Anritsu affixes the C-Tick marking on the following product(s) in accordance with the regulation to indicate that they conform to the EMC framework of Australia/New Zealand.

## C-Tick marking



### 1. Product Model

Model: MW9076xx Optical Time Domain Reflectometer

### 2. Applied Standards

EMC:Emission: EN 61326-1: 2006 (Class A equipment)





# About This Manual

This operation manual explains the operation, calibration and maintenance of the MW9076 Series Optical Time Domain Reflectometer (OTDR). The features of the OTDR are described in “Section 1 Outline.”

This equipment can be connected to an external computer, from which the equipment can be controlled and the measurement results can be read out. Refer to the following operation manual for information on the type of interface to be used for connecting this equipment to an external computer.

MW9076 Series Serial Interface Operation Manual (M-W1660AE)

**1**

**2**

**3**

**4**

**5**

**6**

**7**

**8**

**9**

**Appendix**

**Index**

# Table of Contents

<b>For Safety .....</b>	<b>iii</b>
<b>About This Manual .....</b>	<b>I</b>
<b>Section 1 Outline.....</b>	<b>1-1</b>
1.1 Overview of MW9076 Series Optical Time Domain Reflectometer .....	1-2
1.2 Features .....	1-4
1.3 Loss and Total Return Loss Measurement and Splice & Return Loss Measurement .....	1-11
1.4 Reflection Height Measurement .....	1-12
1.5 Total Return Loss Measurement .....	1-13
1.6 Linear Approximation Methods LSA/2PA .....	1-14
<b>Section 2 Before Use .....</b>	<b>2-1</b>
2.1 Equipment Composition .....	2-2
2.2 Connecting the Power Supply .....	2-5
2.3 Battery Pack .....	2-6
2.4 Names of Parts .....	2-8
2.5 Replacing the Optical Connector .....	2-12
2.6 Installing and Removing the OTDR Main Unit .....	2-13
2.7 Connecting the Optical Fiber Cable .....	2-14
2.8 Connecting Peripheral Units .....	2-15
2.9 Precautions .....	2-25
<b>Section 3 Setup and Setting of Peripheral         Units .....</b>	<b>3-1</b>
3.1 Setting Method .....	3-2
3.2 Explanation of Setup Screens .....	3-6
3.3 Setting of the Peripheral Units .....	3-16
3.4 Reading, Saving, and Printing the Settings .....	3-27
3.5 Preview .....	3-33

<b>Section 4 Operation (OTDR Measurement)....</b>	<b>4-1</b>
4.1 Turning on the Power .....	4-2
4.2 Setting the Measurement Conditions .....	4-4
4.3 Starting a Measurement .....	4-9
4.4 Reading the Event Table .....	4-10
4.5 More .....	4-13
4.6 Auto Zoom .....	4-15
4.7 Editing the Events .....	4-16
4.8 Moving to the Manual Measurement Screen .....	4-26
4.9 Using the Repeat Task Function .....	4-30
4.10 Relative Distance Measurement .....	4-39
4.11 Comparing Waveforms .....	4-41
4.12 Measurement Examples .....	4-47
<b>Section 5 Operation (OLTS Measurement)....</b>	<b>5-1</b>
5.1 OLTS Function .....	5-2
5.2 Setup .....	5-3
5.3 Loss Table .....	5-10
5.4 Measurement Example (Optical Loss Measurement) ....	5-13
<b>Section 6 Operation (CD Measurement) ....</b>	<b>6-1</b>
6.1 Measurement Principles .....	6-2
6.2 Outline of Chromatic Dispersion Measurement .....	6-4
6.3 Measurement Procedures (Flow) .....	6-5
6.4 Details of Measurement Procedures .....	6-7
<b>Section 7 Operating the Functions Other Than Measurements .....</b>	<b>7-1</b>
7.1 Print .....	7-2
7.2 File Operation .....	7-8
7.3 Auto Increment Function .....	7-25

1
2
3
4
5
6
7
8
9
Appendix
Index

<b>Section 8 Performance Test and Calibration .....</b>	<b>8-1</b>
8.1 Performance Test .....	8-2
8.2 Calibration .....	8-19
8.3 Performance Test Result Record Form .....	8-20

<b>Section 9 Maintenance .....</b>	<b>9-1</b>
9.1 Optical Connector & Optical Adapter Cleaning .....	9-2
9.2 Cleaning the Floppy Disk Drive .....	9-5
9.3 Self-Diagnosis .....	9-6
9.4 Suggestions for Storage .....	9-8
9.5 Method of Transportation .....	9-9

<b>Appendix .....</b>	<b>App-1</b>
Appendix A Specifications .....	A-1
Appendix B Least Square Linear Approximation Method ..	B-1
Appendix C Splice Loss Measurement Principle .....	C-1
Appendix D Return Loss Measurement Principle .....	D-1
Appendix E Total Return Loss Measurement Principle ....	E-1
Appendix F Settings at Factory Shipment .....	F-1
Appendix G List of Recommended Printers .....	G-1
Appendix H Marker Resolution .....	H-1
Appendix I Simple OTDR Operation Method .....	I-1

<b>Index .....</b>	<b>Index-1</b>
--------------------	----------------

This section explains the features of the MW9076 Series, equipment composition, and the measurement principle. For the performance and function specifications, refer to “Appendix A Specifications.”

1.1	Overview of MW9076 Series Optical Time	
	Domain Reflectometer .....	1-2
1.1.1	Measuring cable loss and distance ....	1-3
1.2	Features .....	1-4
1.2.1	Automatic search of faults	
	· · · Full Auto Mode/Auto Mode .....	1-4
1.2.2	Detailed measurement: Manual Mode	1-5
1.2.3	Making the settings while checking the measured waveform .....	1-6
1.2.4	Simplification of repeated measurements ...	1-6
1.2.5	Reducing measurement errors .....	1-7
1.2.6	Making high resolution measurements	1-7
1.2.7	Automatic detection of warning points	1-7
1.2.8	Event functions .....	1-8
1.2.9	Averaging and real-time functions .....	1-8
1.2.10	Saving and reading the measured waveforms .....	1-8
1.2.11	Waveform comparison function .....	1-9
1.2.12	Changing from manual mode to automatic mode .....	1-9
1.2.13	Auto power off and automatic waveform save function .....	1-9
1.2.14	Visible LD .....	1-9
1.2.15	Automatic allocation of the marker for the calculation of Splice Loss .....	1-9
1.2.16	Versatile measurement functions .....	1-10
1.3	Loss and Total Return Loss Measurement and Splice & Return Loss Measurement .....	1-11
1.4	Reflection Height Measurement .....	1-12
1.5	Total Return Loss Measurement .....	1-13
1.6	Linear Approximation Methods LSA/2PA .....	1-14

## 1.1 Overview of MW9076 Series Optical Time Domain Reflectometer

The MW9076 Series Optical Time Domain Reflectometer (OTDR) can be used as an OTDR for supporting measurements at various wavelengths by combining an MW9076 Series OTDR main unit with an MU250000A/A1/A4 display unit.

Since the model name of this equipment and the name of the OTDR main unit are very similar and can give rise to confusion, they are distinguished in this document as shown below. The term “MW9076\* OTDR” refers to the combination of an MW9076 Series OTDR main unit and an MU250000A/A1/A4 display unit, while the term “MW9076\* OTDR main unit” refers to a single MW9076 Series OTDR main unit.

The MW9076 Series OTDR has been developed for the detection of faults in optical fibers during the installation and maintenance of optical fiber systems. It can be used to measure the total loss, interval loss, and cable length (distance) of an optical fiber system using laser light.

An automatic measurement procedure and small lightweight portable design facilitate its use in field installation and maintenance of optical fibers. In addition, the internal memory can be used to save measured waveform data for subsequent analysis and print-out. The MW9076 Series also has an interface for reading the measurement results from a computer connected to this equipment.

Faults are located and losses can be automatically measured by just pressing the [Start] key after setting the measurement conditions on the Setup screen.

Automatic Fault Location    Full Auto Mode/Auto Mode

Detailed Measurement of Loss and Splice Loss    Manual Mode

Moreover, when the visible LD option is used, light leakage from the cable can be easily observed.

In addition, when MW9076B/B1/C is used, the Optical Light Source and the Optical Power Meter (optional) function can be added as the Optical Loss Test Set (OLTS) for easy measurement of the total loss of optical fibers.

### 1.1.1 Measuring cable loss and distance

When laser light of a specific wavelength is introduced into an optical fiber cable from the OTDR, it is scattered as it propagates towards the far end of the cable. Part of this scattered light returns to the OTDR as backscattered light. The intensity of this backscattered light is measured and is used to determine the cable loss. In addition, the time duration from the introduction of the optical pulse into the fiber unit till it return to the OTDR from a fault is used to calculate the distance to the fault. For an accurate measurement, the light introduced into the fiber must propagate to the far end of the cable and return to the OTDR as backscattered light before the next optical pulse is sent into the fiber. Therefore, the length of the measured cable is set as “Distance Range” on the Setup screen. When the “Distance Range” and “Pulse Width” are set to Auto, the OTDR sets the optimum value of these parameters.

# 1.2 Features

## 1.2.1 Automatic search of faults . . . Full Auto Mode/Auto Mode

This function is convenient to use when the user does not know the locations of the faults.

In this mode, faults in the cable are detected and displayed by pressing the **Start** key. Set the measurement mode to Full Auto or Auto in advance on the Setup screen. After the measurement is completed, the following screen is displayed. Each fault point is indicated by an event symbol and the fault data is displayed under the waveform in the form of a table. The fault is called an event and this table is called an event table.

In Full Auto mode, the optimum “Distance Range”, “Pulse Width” and “Number of times Averaging is performed” are estimated by the OTDR. In Auto mode, these values are set on the Setup screen.

For details, refer to “Section 4.2 Setting the Measurement Conditions.”

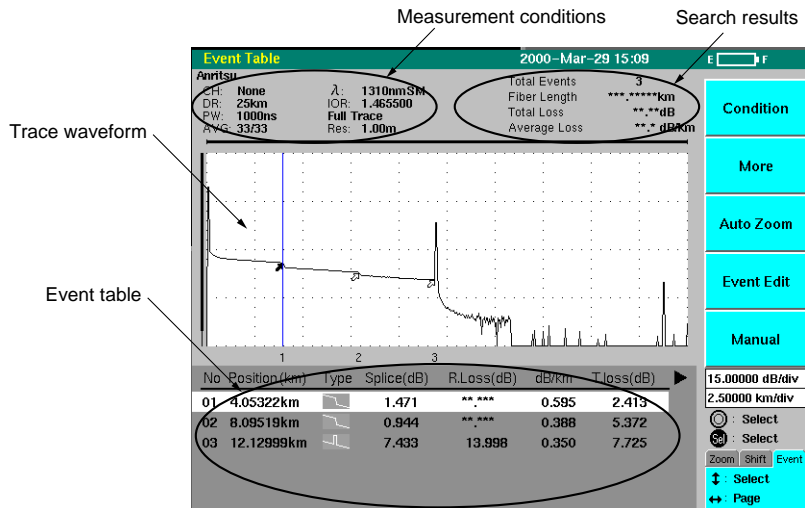

- **Trace Waveform**  
The trace waveform is displayed with the attenuation on the y-axis and the distance on the x-axis. The left-hand side of the trace display shows the OTDR optical output while the right-hand side shows the far end of the fiber cable. Each fault in the cable is marked with an event symbol.
- **Measurement Conditions**  
Light Wavelength, Distance Range, Pulse Width, Index of Refraction (IOR), Number of times Averaging is performed
- **Search Results**  
Total Number of Faults, Total Fiber Length, Loss of the Entire Fiber
- **Event Table**  
Number of Faults counted from the OTDR (No.), Distance from the OTDR, Splice Loss, Return Loss, Total loss to the Fault.

**Note:**

Automatic measurement is a supporting function which enables to operate easier, it doesn't assure results. As there is a case of miss detection, check the waveform as well.



### 1.2.2 Detailed measurement: Manual Mode

In this mode, any position on the fiber can be measured by moving the markers to it. Set the measurement mode to Manual in advance on the Setup screen and press the **(Start)** key. In this mode, “Loss and Total Return Loss Measurement” for obtaining the loss and total return loss of the cable and “Splice & Return Loss Measurement” for obtaining the connection loss and return loss can be selected. Two markers are displayed for “Loss Measurement” and six markers are displayed for “Splice & Return Loss Measurement.” A vertical cursor is displayed at the selected marker. The measured values are displayed at the bottom of the screen. Furthermore, in this mode, the Averaging mode which averages the measured value of each sweep, or the Real Time mode which rewrites the waveform at each sweep, can be selected.

The following figure shows an example of Splice & Return Loss Measurement. For details, refer to “Section 4.8 Moving to the Manual Measurement Screen.”

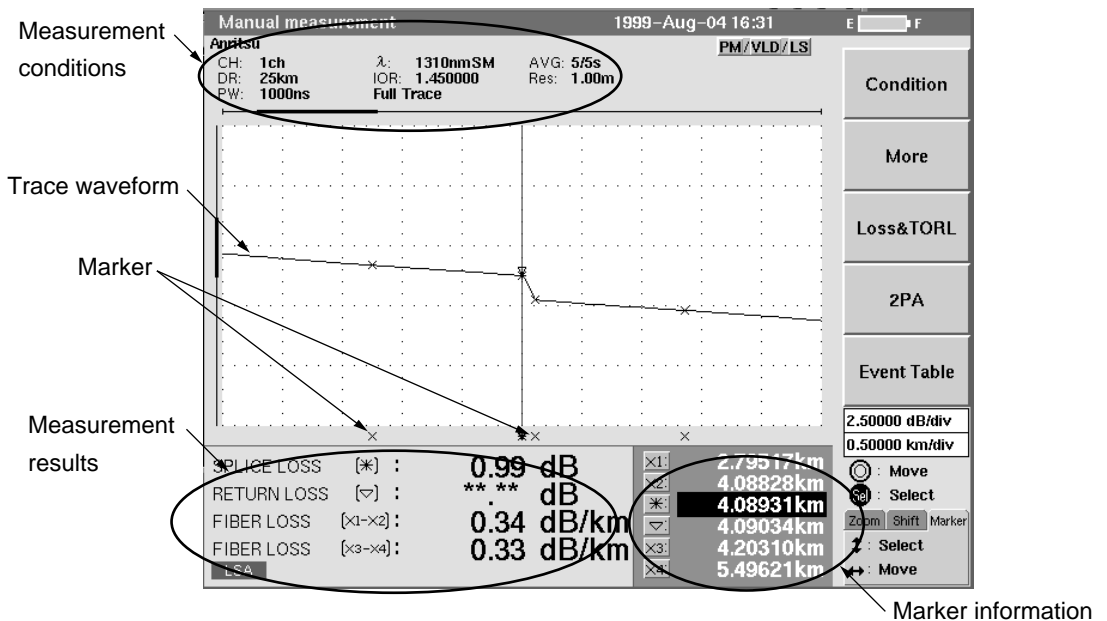

- Trace Waveform
 

The trace waveform is displayed with the attenuation on the y-axis and the distance on the x-axis.
- Measurement Conditions
 

Light Wavelength, Distance Range, Pulse Width, Index of Refraction (IOR), Number of Times of Averaging
- Measurement Results
 

Splice Loss, Return Loss  
 Loss between Marker x1 and x2 (Fiber Loss x1 - x2)  
 Loss between Marker x3 and x4 (Fiber Loss x3 - x4)
- Marker
 

Six markers are displayed on this screen. The markers are indicated by numbers x1, x2, x3, x4 from the left.
- Marker Information
 

The position information for each marker and that for the OTDR is displayed.

### 1.2.3 Making the settings while checking the measured waveform

#### **Preview mode**

In the Preview mode, the trace waveform is refreshed almost in real time (in about 0.1 to 0.5 seconds), permitting the adjustment of the connector connections while checking the waveform. Since the preview mode is used to check the shape of the waveform, it cannot be used as a measurement result.

#### **Setting the measurement conditions while checking the measured wavelength.**

Measurement conditions can be set on the OTDR while the measurement is in progress for those measurements and the measured waveform is displayed. Therefore, the measurement conditions can be easily fine-tuned while checking the measured results.

### 1.2.4 Simplification of repeated measurements

The OTDR provides functions for eliminating the necessity to perform repeated operations such as measuring the cores of a multi-core fiber cable or measures the wavelength by two or more.

#### **Continuous automatic measurement of a multi-core fiber using the optical channel selector.**

Continuous, automatic measurements of a multi-core (4-core or 8-core) fiber can be easily performed by installing an optical channel selector unit (optional) on the OTDR. Since it can be integrated into the main unit, measurements can be easily performed even on the field. The external optical channel selector can be controlled by using the RS-232C interface.

#### **Continuous measurement by automatic switching of any combination of wavelengths.**

The OTDR can perform measurements by automatically switching any combination of selectable wavelengths (determined by the OTDR main unit), allowing the user to complete the measurements of all selected wavelengths in a single operation. Therefore, the user does not need to perform repeated measurements of different wavelengths.

## 1.2.5 Reducing measurement errors

The OTDR provides check functions for preventing an incorrect measurement due to simple errors such as incorrect fiber connection.

### **Checking the communication light in the fiber under test**

Any communication light in the fiber under test may affect the communication itself and prevent the OTDR from performing an accurate measurement. To eliminate this problem, the OTDR has the Active Fiber Check function for checking the communication light in the fiber cable connected to the OTDR.

### **Checking the connection states to the fiber under test**

The OTDR checks if the fiber under test is firmly connected to the optical connector of the OTDR main unit in order to eliminate connection errors and to ensure accurate measurements.

## 1.2.6 Making high resolution measurements

The number of measured data points can be switched among the following three settings: high speed, normal speed, and high resolution. Since 40001/50001 points are sampled in the high resolution mode, all errors that could not be detected with the previous equipment can now be detected. It is also possible to measure long distances with high resolution or to make a rough measurement at high speed as required.

## 1.2.7 Automatic detection of warning points

By setting a warning level (threshold value) in advance, the OTDR automatically displays marks for measurement results of the event table that have exceeded the warning level. By checking the marks, it can be easily determined if the measurement results are acceptable or not.

## 1.2.8 Event functions

The fault, the connecting point, and the far end of the fiber cable at the time of Full Auto mode/Auto mode measurement are known as events. Events can be easily measured using this event function.

### Editing the event points

When performing an automatic fault search in Full Auto/Auto mode, the OTDR may misidentify normal points as faults or miss real faults due to noise. By switching to the Edit mode after the waveform is displayed, the user can eliminate or move misidentified faults and add new faults. This function enables the user to correct the erroneous faults and perform measurement.

### Event registration function

With the event registration function, measuring points are preset as events and measurements are made at the preset points. This function is convenient for making repeated measurements at the same fusing or connecting points during the measurement of a multi-core fiber.

## 1.2.9 Averaging and real-time functions

The intensity of the backscattered light changes with distance. This effect is particularly large at the far end of the fiber and is observed on the screen as noise. When the Averaging function is set to ON, the measurement is averaged each time an optical pulse is sent into the fiber so that noise is reduced and a smoother waveform is observed. Set the Averaging Time or Number of Times Averaging is performed as the Averaging completion condition on the Setup screen. When the **F2** (Real Time) key is pressed, the OTDR enters the Real Time mode in which the screen data is rewritten each time a measurement is performed.

## 1.2.10 Saving and reading the measured waveforms

The waveform displayed on the screen can be saved in the OTDR internal memory, a memory card, or a FD. These saved waveforms can be read or printed by a printer connected to the OTDR as required. And, the OTDR can search the read waveform for faults or measure the points on which the markers are set.

### File name and title auto-increment function

This function automatically increments the number specified for a title or file name each time the file is saved. This function eliminates the inconvenience of rewriting the title contents or file name each time the file is saved.

### 1.2.11 Waveform comparison function

Reads the waveform that is saved in a file as the reference waveform for OTDR. The reference waveform remains displayed on the OTDR monitor during measurement. This function displays the difference between the measured and reference waveforms, thus the difference in distance and level easily observable. This makes it convenient to monitor aging or compare multiple fibers. See “Comparing Waveforms” in section 4.11 for details.

### 1.2.12 Changing from manual mode to automatic mode

If the data has been collected in the Manual mode and then it is searched for faults in the Auto mode, event markers are displayed at the faults and an Event Table is displayed. Since a waveform, for which a sufficiently long time interval is used for averaging, can be used in this mode, the fault misdetection rate can be reduced. It is also possible to edit event points as in Auto mode.

### 1.2.13 Auto power off and automatic waveform save function

When a key or a button is not pressed for a specified period of time, the power is automatically switched off. This function can reduce the wastage of power when batteries are used. In addition, this function stores the current waveform to be measured automatically when the auto-power off is activated so that the measured result is not erased. The Setup screen is displayed when the power is turned on again. Select “Close” on this screen to display the stored waveform. When turning off the power for the unit using the power switch, it is possible to set whether to save the waveform or not before just as with the auto power off function.

### 1.2.14 Visible LD

A light source with 635 nm wavelength is available as an option. Since the light source emits visible light, faults in the dead zone of the OTDR can be detected using leaked light. It can also be used for collating the cores of the multi-core optical fiber.

### 1.2.15 Automatic allocation of the marker for the calculation of Splice Loss

When the measurement is switched from Loss & Total Return Loss Measurement to Splice & Return Loss Measurement, five supplementary markers are automatically allocated at the most appropriate position around the \* marker. This eliminates having to allocate the supplementary markers.

## 1.2.16 Versatile measurement functions

### **OLTS (Optical Loss Test Set) measurement function.**

The OLTS measurement is used for measuring the loss of the fiber under test by connecting the fiber under test between the light source and the optical power meter. Measurements can be made by first reading the optical power of the light source as the reference, and by obtaining the difference between the optical power of the object under measurement using the optical power meter and the reference optical power.

Since the MW9076B/C has a built-in light source as standard, it can make OLTS measurements by installing an optional optical power meter. In addition, the light source function and the optical power meter function can be used separately.

The MW9076B1 can have only the optical power meter function with the optional optical power meter installed.

### **Chromatic Dispersion measurement function**

The MW9076D/D1 can perform Chromatic Dispersion measurements using only one side of the fiber cable. This function allows the measurement of optical fiber cables that have already been installed.

## 1.3 Loss and Total Return Loss Measurement and Splice & Return Loss Measurement

Either Loss and Total Return Loss Measurement or Splice & Return Loss Measurement can be selected in the Manual mode.

### (1) Loss and Total Return Measurement

Using this measurement, the distance between the  $\times$  and  $*$  markers (DISTANCE), loss (LOSS), loss per km (FIBER LOSS), and total return loss (TOTAL RETURN LOSS) can be measured. However, Total Return Loss cannot be measured during waveform sweeping.

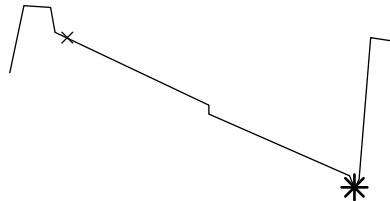

### (2) Splice and Return Loss Measurement

Using this measurement, the loss at a connection can be measured. In this measurement, a  $*$  marker is set at the connection and a pair of  $\times$  markers is set on each side of the  $*$  marker as shown in the figure below. If Fresnel reflection occurs at the connection, a  $\nabla$  marker is set at the peak point.

The four  $\times$  markers are called  $\times 1$ ,  $\times 2$ ,  $\times 3$ , and  $\times 4$  from the left. The splice loss is determined from the vertical difference at the  $*$  marker between straight lines drawn between the  $\times 1$  and  $\times 2$ , and  $\times 3$  and  $\times 4$  markers.

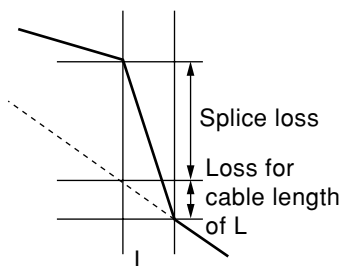

In this measurement, the distance between the  $\times 1$  and  $\times 2$  markers and that between the  $\times 3$  and  $\times 4$  markers, as well as the fiber loss (loss per unit length) are also displayed.

There is a section at the splice where the back scattered light cannot be measured precisely during a time which is equivalent to the pulse width. The distance  $L$  shown in the figure on the left is equivalent to this section. Because of the distance  $L$ , the fiber loss in the  $L$  section is included in the measurement if splice loss is measured using the same method as Loss Measurement.

More detailed explanations of the splice loss measurement and the return loss measurement are given in "Appendix C" and "Appendix D," respectively. For the total return loss, refer to "Section 1.5 Total Return Loss Measurement."

## 1.4 Reflection Height Measurement

The reflection height measurement can be performed if “Height” is selected instead of “Return Loss” in the “Reflective type” of the Display Setting of Menu.

If “Splice & Return Loss Measurement” is selected in the Manual mode, reflection (Height), instead of the return loss, is measured. In this measurement, six markers are set in the same way as the Splice & Return Loss Measurement.

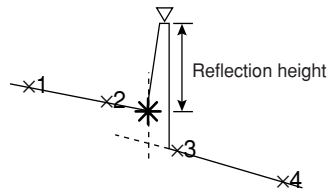

The measured value can be obtained from the difference in levels between the \* marker and ▽ marker.

In Auto mode, reflection (height), instead of the return loss, is measured. In the automatic detection of events, the item “Return Loss” in the auto measurement parameter on the Setup screen (2/3) cannot be used.



## 1.5 Total Return Loss Measurement

This measurement calculates the total return loss and displays it on the screen.

### (a) Auto measurement mode

The total return loss from 0 km to the far end of the fiber cable is measured. The backscattered level used as reference is in the location shown in the following figure.

To measure the relative distance discussed later, the backscattered level at the zero cursor location is used as reference.

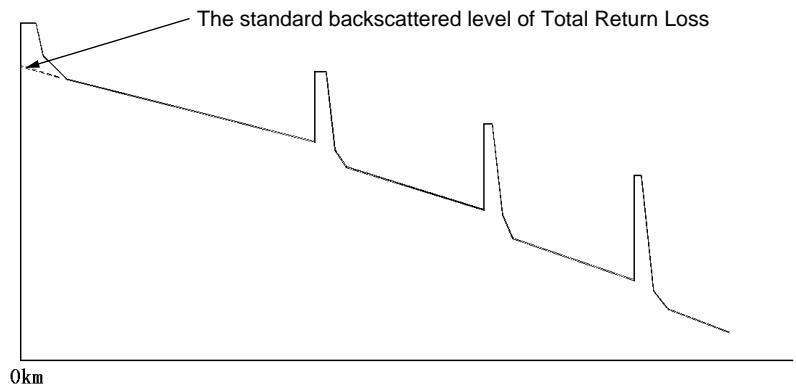

### (b) Manual measurement mode

After sweeping is completed in the Loss Measurement mode, the total return loss between two markers ( $\times$  and  $*$ ) is calculated and displayed. These markers can be moved to any position using the cursor keys.

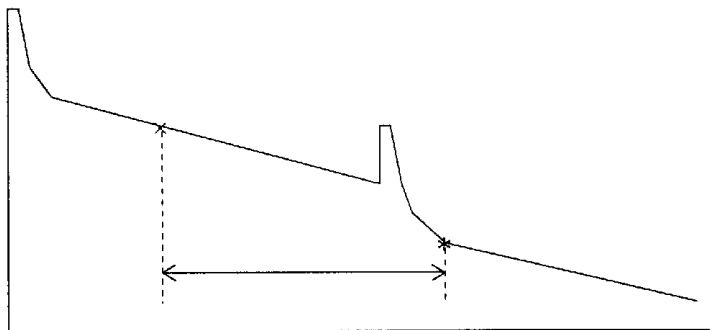

Refer to “Appendix E” for an explanation of the total return loss measurement.

# 1.6 Linear Approximation Methods LSA/2PA

In the Loss Measurement and Splice Return & Loss Measurement, the loss is found by drawing an imaginary line between the two set markers. There are two methods for drawing the line.

## LSA (Least Square Approximation) Method

In this method, the line is drawn by computing the least square of the distances from all the measured data between the two markers. This method is useful when the data contains noise. Refer to Appendix B for further details.

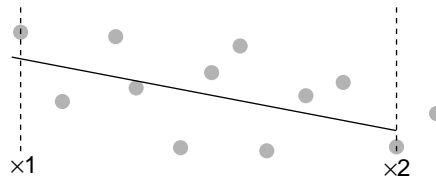

## 2PA (Two Point Approximation) Method

This method draws a line linking the two measured data points at the two markers.

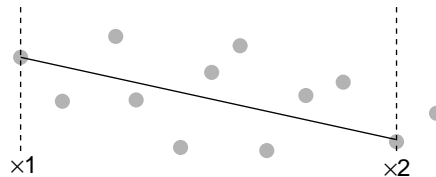

## Comparison on LSA and 2PA

These two methods are compared for Loss Measurement and Splice Loss & Return measurement when the data contains a lot of noise as follows:

### When LSA is selected

When LSA is chosen in the Loss Measurement, there is a probability of the occurrence of a large error when a fiber with splice loss is measured along its length.

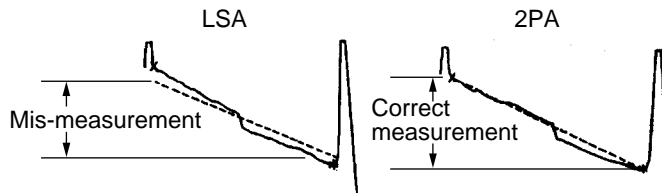

### When 2PA is selected

There is a probability of the occurrence of a large error when the noise is large. An example of the Splice & Return Loss Measurement is shown below.

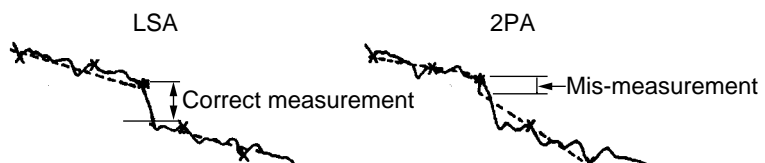

## Section 2 Before Use

This section provides important information that should be thoroughly understood before actually using the MW9076 Series. In particular, it explains how to charge the battery at first use after purchasing the OTDR.

2.1	Equipment Composition .....	2-2
2.1.1	Standard composition .....	2-2
2.1.2	Options .....	2-4
2.2	Connecting the Power Supply .....	2-5
2.3	Battery Pack .....	2-6
2.3.1	Installing the battery pack .....	2-6
2.3.2	Charging the battery pack .....	2-7
2.4	Names of Parts .....	2-8
2.4.1	Names of parts on the front, top, and left sides of the device .....	2-8
2.4.2	Names of parts on the rear, bottom, and right sides of the device .....	2-10
2.5	Replacing the Optical Connector .....	2-12
2.6	Installing and Removing the OTDR Main Unit ...	2-13
2.7	Connecting the Optical Fiber Cable .....	2-14
2.8	Connecting Peripheral Units .....	2-15
2.8.1	Inserting and removing a memory card .....	2-15
2.8.2	Inserting and removing a floppy disk ..	2-16
2.8.3	Connecting an optical channel selector .....	2-17
2.8.4	Connecting a printer .....	2-21
2.8.5	Connecting a computer .....	2-22
2.8.6	Connecting an external monitor .....	2-23
2.8.7	Connecting a keyboard .....	2-24
2.9	Precautions .....	2-25

## 2.1 Equipment Composition

### 2.1.1 Standard composition

The standard composition of MW9076 Series OTDR is listed in the following table. After unpacking, check the packing list and make sure that all the components are included. If any part is missing or damaged, contact Anritsu or your Anritsu sales agent immediately.

	Name	Q'ty	Model Name or Ordering No.	Remarks
Main unit	OTDR main unit	1	MW9076*	
Accessories	Packing list	1	CGR-B/802D or CGR-B/802E W1659AE W1660AE	Included in the accessory box
	Battery pack	1		
	Operation manual	1		
	Serial interface operation manual	1		

	Name	Q'ty	Model Name or Ordering No.	Remarks
Main unit	Display unit	1	MU250000A, MU250000A1 or MU250000A4	
Accessories	Packing list	1	Z0402 Z0403A	Included in the accessory box (with an exception of the protective cover)
	AC adapter	1		
	Power cord	1		
	Protective cover	1		
	Strap with hooks	1		

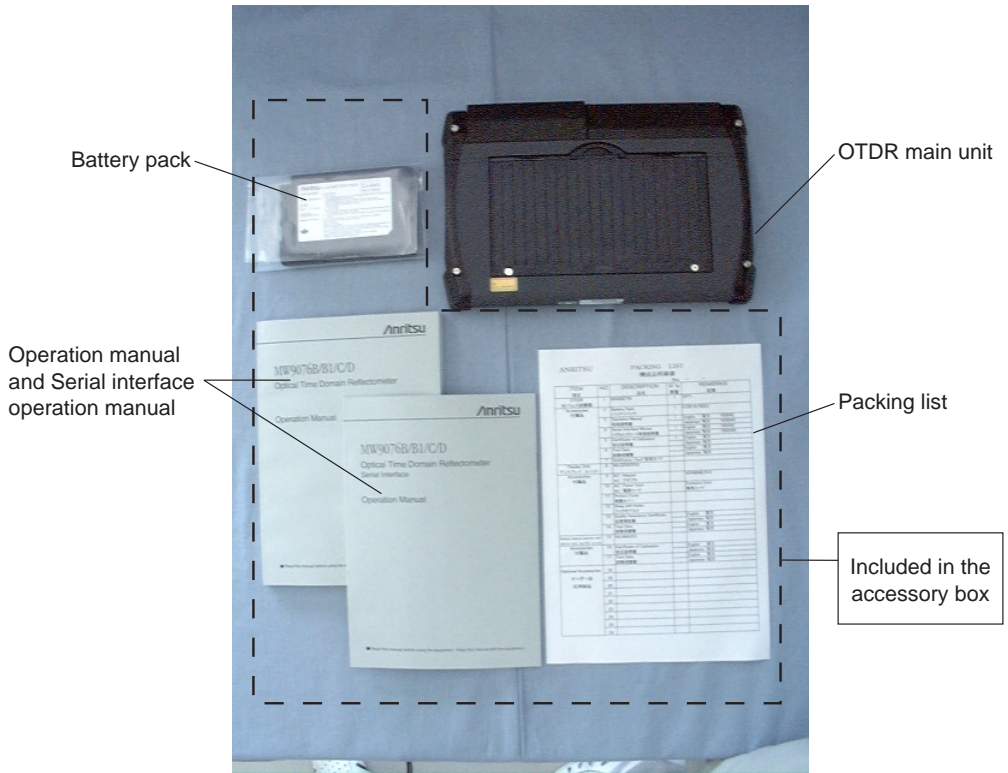

**OTDR Main Unit and Accessories**

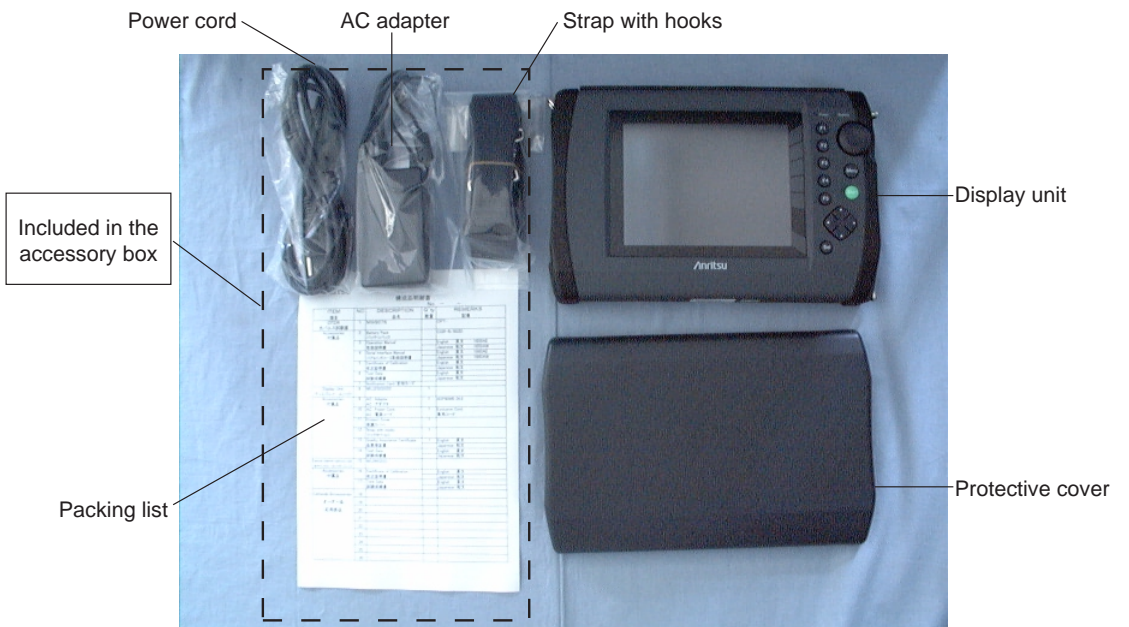

**Display Unit and Accessories**

## 2.1.2 Options

The following optional parts can be chosen for the OTDR. Note that some may need to be installed in an Anritsu factory. For the specifications, refer to “Appendix A Specifications.”

### **Visible LD (MW9076B/B1/C/D/D1/J/K-01)**

Fiber abnormalities can be visually detected using this light source.

It is necessary to bring the OTDR to the Anritsu factory for its installation.

### **Optical power meter (MW9076B/B1/C-02)**

This optional unit adds the function of the optical power meter to the OTDR. By combining it with a light source, the loss of the fiber under test can be easily measured.

It is necessary to bring the OTDR to the Anritsu factory for its installation.

### **High power optical power meter (MW9076B/B1/C-03)**

A power meter for a high input of +23 dBm.

Simultaneous installation with the optical power meter (MW9076B/B1/C-02) is not allowed.

It is necessary to bring the OTDR to the Anritsu factory for its installation.

### **Optical connectors (MW9076B/B1/C/D/D1/J/K-37-43)**

Connectors for the OTDR main unit input/output, optical power meter input, and light source output

-37: FC, -38: ST, -39: DIN, -40: SC, -43: HMS-10/A

They are all PC-type connectors.

Option 43 is for MW9076B/B1/C/D/D1 only.

### **Built-in optical channel selector (MU960001A, MU960002A)**

MU960001A: 4 channels

MU960002A: 8 channels

The optical channel selector mounted between the display unit and the OTDR main unit can be used as an integrated unit. This unit is for SM fiber only.

### **Other language display**

-18: Chinese language display

Other languages are scheduled to be added one after another.

## 2.2 Connecting the Power Supply

### Connecting the AC adapter

Use the supplied accessory AC adapter.

Using an AC adapter other than the supplied one may damage the battery and the OTDR.

Connect the AC adapter as shown in the figure below.

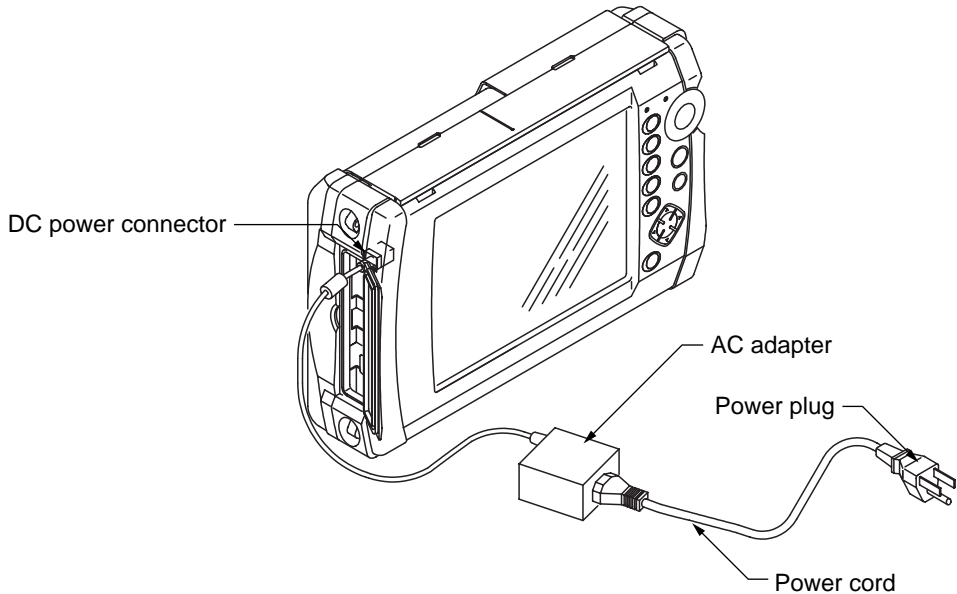

### CAUTION

Use a three-pin power plug. If you do not have a power socket for a three-pin power plug, convert the three-pin power plug into a two-pin power plug using a conversion connector and connect the ground line to the earth. Failure to ground may damage the OTDR or you may receive an electric shock.

The AC adapter is for the MW9076 only. Connecting it to other devices may cause a failure or fire, Never use it for other devices.

## 2.3 Battery Pack

### 2.3.1 Installing the battery pack

This section explains how to install/remove the battery pack to/from the OTDR. Read the following explanation when replacing the battery pack.

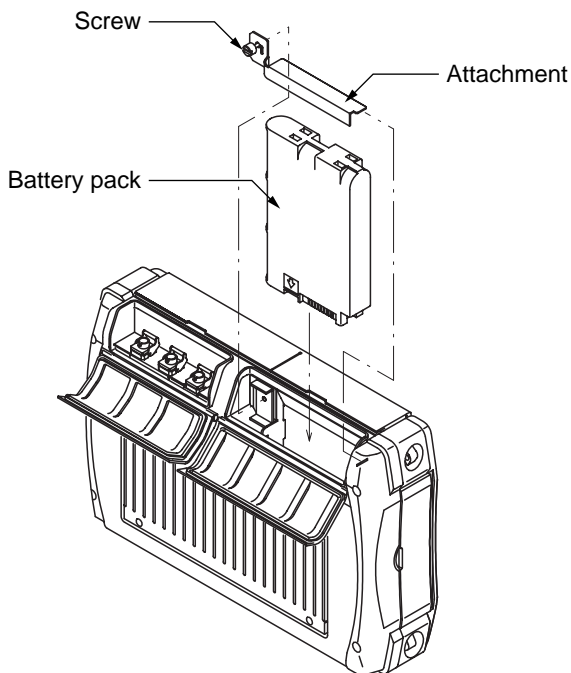

#### Installing the battery pack

- (1) Insert the battery pack into the OTDR main unit. (See the above figure for the correct insertion direction of the battery pack.)
- (2) Install the attachment. Hook the attachment into the hollow on the front right in the above figure and insert the attachment into the projection at the center.
- (3) Fix the attachment with screws. Fasten screws with a screwdriver.

#### Removing the battery pack

- (1) Loosen the driver with a screwdriver.
- (2) Remove the attachment.
- (3) Pull out the battery pack.

### CAUTION

---

**Turn off the power before removing the battery pack. The battery pack, the OTDR main unit and the display unit may be damaged if the operation is performed with the power turned on.**

---



### 2.3.2 Charging the battery pack

Charge the battery at an ambient temperature between 0 and 40 °C. Charging does not start if the battery residual capacity is more than 80%. The battery pack can be charged even when it is installed in the OTDR main unit. To charge the battery pack, connect the supplied accessory AC adapter to the DC power connector of the OTDR main unit, and then plug the cord into a receptacle. When charging starts, the orange battery lamp is illuminated. Charging is performed irrespective of whether the power switch is turned on or off.

The battery charging takes for three hours to complete. Since the battery pack is not charged at product shipment, charge it before using the products. In addition, the battery pack is a consumable supply. The lifetime of the battery is reached when the operating time becomes extremely short even if the battery is fully charged. Replace the battery pack with a new one.

**A charged battery pack becomes empty in about one week. Charge it before using this device.**

**The battery pack may not start charging even if the ambient temperature is between 0 and 40 °C when the temperature of the battery exceeds this range.**

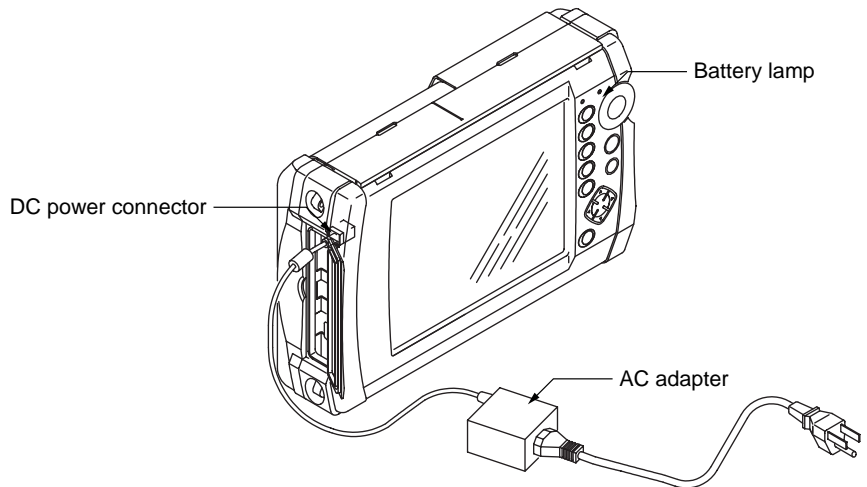

The charging status of the battery pack can be visually checked by the color of the battery pack and lamp indication.

Lamp status	Battery pack status	Remarks
Green lamp is On	Discharging is under way or charging is completed	
Red lamp is On	Charging is required.	Remaining charge: Less than 5 %
Orange lamp is On	Charging	Remaining charge is less than 99.5 % and AC adapter is connected.
Red lamp is blinking	Battery pack abnormality	Some abnormal condition such as over discharge occurs.
Off	No battery	Battery pack is not installed

**If the battery pack is not used for a long time, over discharge may occur. In this case, charge the battery for 12 hours to return the battery pack to normal.**

The residual capacity of the battery pack can also be checked on the display. See “4.1 Turning On the Power” for more information.

## 2.4 Names of Parts

Check the name and function of each part.

### 2.4.1 Names of parts on the front, top, and left sides of the device

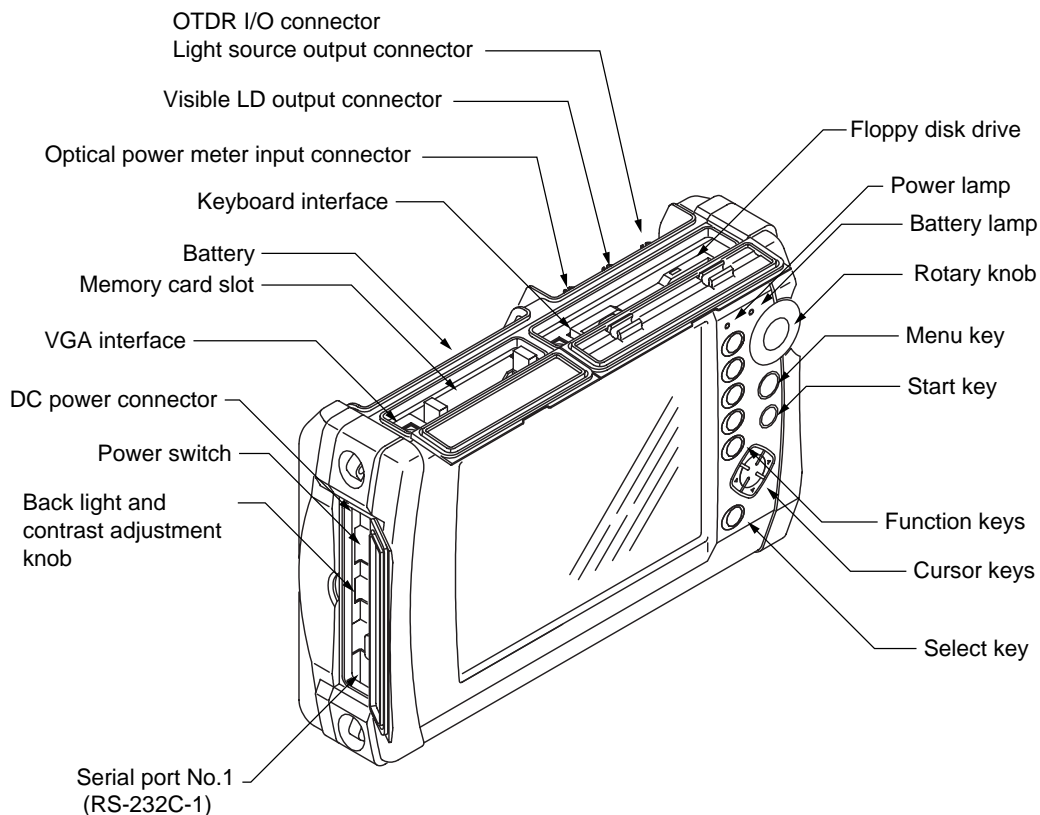







#### Power switch

A switch for turning on/off the power. ON when "I" is pressed.

#### Back light and contrast adjustment knob

A knob for adjusting the contrast and brightness of the back-light. The brightness of the back-light is switched by clicking the volume switch. The contrast is supplied when the display unit MU250000A1/A4 is installed. The contrast can be adjusted by turning the volume switch.

<b>Status Display Lamp</b> <b>Power lamp</b>	It is illuminated when the power switch is turned on and power is supplied to the OTDR main unit.
<b>Battery lamp</b>	Indicates the status of the battery by its color or by blinking. For the details of the display, refer to “Section 2.3.2 Charging the battery pack.”
<b>Start Key</b>	When this key is pressed, the measurement is started and laser light is emitted from the OTDR I/O connector. Laser output can be stopped by pressing the  (stop) function key.
<b>Select Key</b>	This key switches the functions of the Cursor keys. For details, refer to Page 2-11 “What is a card?”
<b>Cursor Keys</b>	The cursor keys consist of the top, bottom, right, and left keys. The function of each key is displayed in the card displayed at the lower right of the screen. In this manual, these keys are indicated by,  ,  ,  , and  arrows. For information on the card, refer to Page 2-11 “What is a card?”.
<b>Function Keys</b>	Function Keys F1 to F5 are provided. The function of each key is displayed on the right-hand side of the screen in a region known as the function key label.
<b>Menu Key</b>	Measurement-related functions are always displayed in the function key label. Additional functions such as screen color and file operation can be selected by pressing the Menu key. The menu window can be displayed by pressing the Menu key. The functions that can be selected on this screen are displayed in the function key label. The menu items can be switched by pressing the  and  keys. The functions can be selected using the function keys.
<b>Rotary Knob</b>	Mainly used for moving the selected markers. When a marker card is selected, it functions in the same way as the cursor keys. By pressing the entire rotary knob, markers to be moved can be switched.

## 2.4.2 Names of parts on the rear, bottom, and right sides of the device

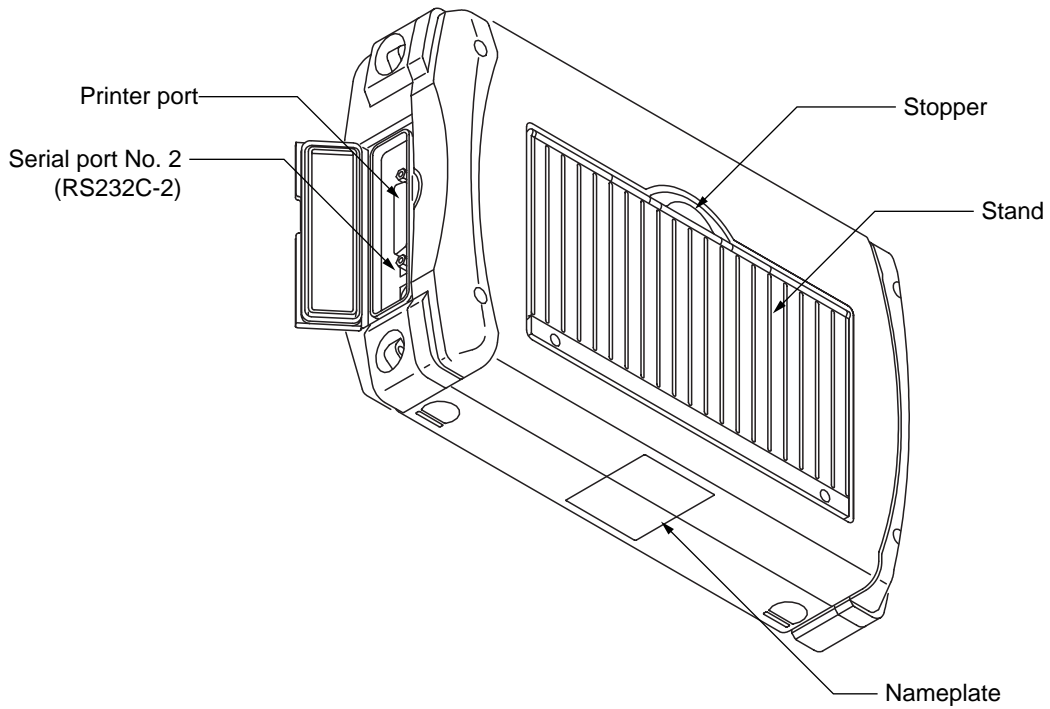

### Nameplate

The serial number of the equipment and the option numbers of the installed options are indicated on the nameplate.

### Stand

Use this stand by drawing it out for the vertical placement of the OTDR. Pull the stand stopper upward to draw out the stand.

**What is a card?**

When the cursor keys are effective, cards explaining the operations that can be performed on this screen are displayed on the lower right-hand side of the screen. The card at the front of the pile explains the functions of the Cursor keys on the card. The Cursor key functions depends on which card is at the front of the pile.

The card which comes to the front changes every time **Select** is pressed, . The display on the right-hand side of the **^** and **v** keys and **<** and **>** keys indicate the functions. If nothing is displayed on the right-hand side of the arrows, no operation is performed even if a cursor key is pressed.

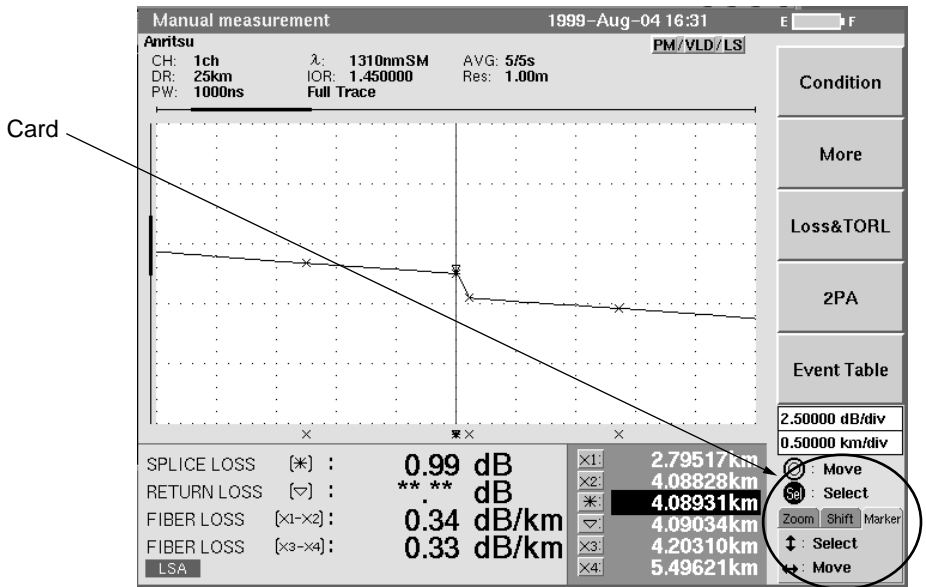

For example, in the figure above, the marker card is at the front, so the Cursor keys can be used for selecting and moving markers.

The Cursor keys **^** and **v** are used for selecting the markers, while the Cursor keys **<** and **>** are used for moving the markers.

To enlarge the waveform, press **Select** to put the zoom card at the front.

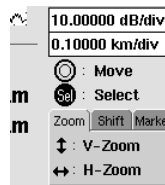

Now, the Cursor keys **^** and **v** are used for scaling in the vertical direction, while the Cursor keys **<** and **>** are used for scaling in the horizontal direction.

## 2.5 Replacing the Optical Connector

To replace the optical connector, pull the lever towards you until the latch is released. Then, remove the connector by lifting it.

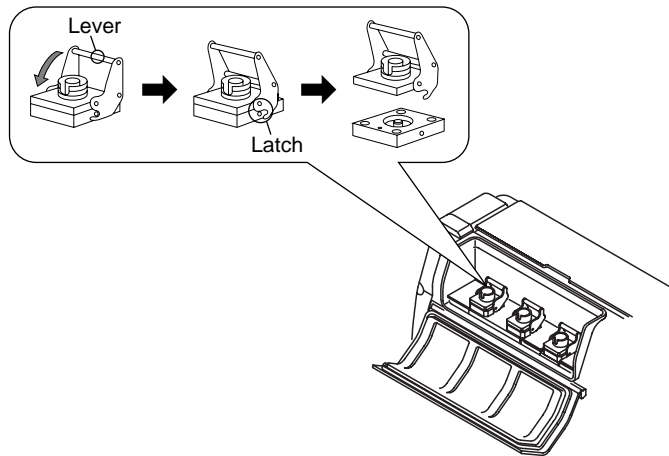

Connector types are shown below for reference.

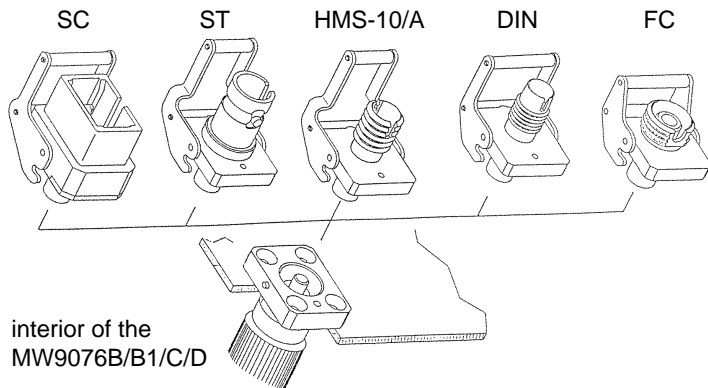

### CAUTION

When replacing the optical connector, take care not to damage the connector and the connecting surface of the connector.

### WARNING

NEVER look directly into the laser radiation emitted from the OUTPUT connector or the end of the cable connected to the OTDR. If you do so, the laser light may damage your eyes.

## 2.6 Installing and Removing the OTDR Main Unit

This section explains how to install and remove the MW9076\* OTDR main unit. Read the following explanation when replacing the OTDR main unit or installing a built-in optical channel selector.

### Removing the OTDR main unit

- (1) Turn off the power switch of the equipment.
- (2) Loosen the four screws used for fastening the OTDR main unit to the rear side of the equipment (see the figure below) using a screwdriver. The four screws cannot be completely unscrewed from the equipment.
- (3) After loosening the four screws, the OTDR main unit can be separated from the display unit.

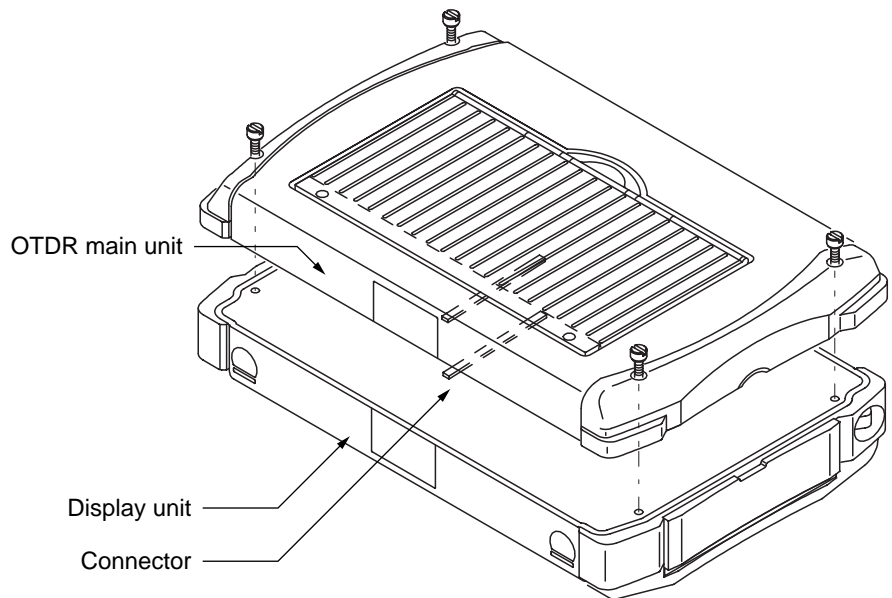

### Installing the OTDR main unit

- (1) Place the display unit under the OTDR and make adjustments in such a manner that the connectors of the display unit and the OTDR main unit are aligned. Take care not to damage the connectors during the operation.
- (2) Fasten the four screws of the OTDR main unit (see the figure above) with a screwdriver.

## CAUTION

Turn off the power before the installation or removal of the OTDR main body. The OTDR main unit and the display unit may be damaged if operation is performed with the power turned on. Perform the operation with the protective cover attached, or the display unit is damaged.

## 2.7 Connecting the Optical Fiber Cable

Open the dust proof cover of the OTDR I/O connector and connect the optical cable as shown in the figure below.

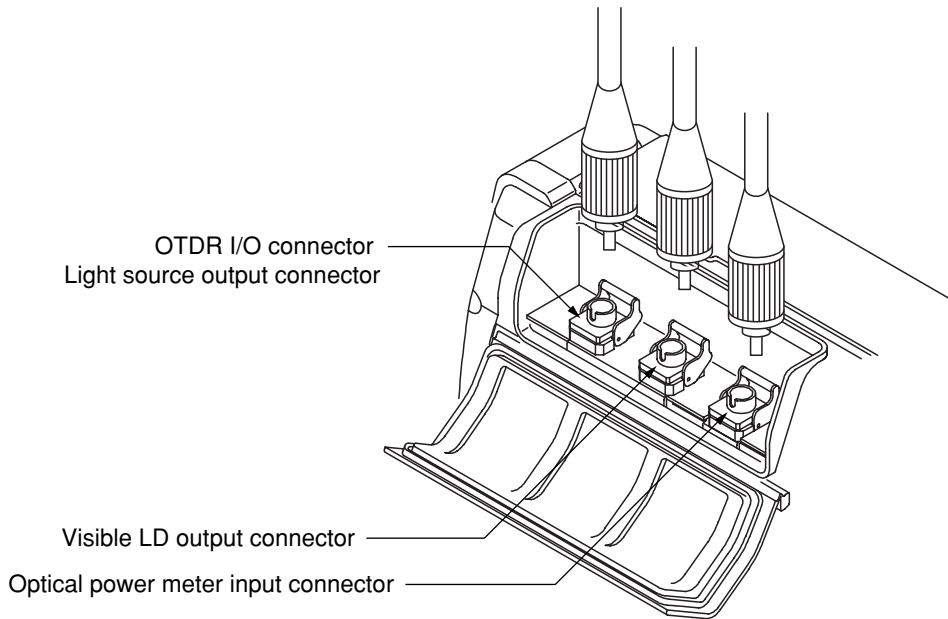

A common connector for OTDR I/O and light source output is provided if MW9076B/C is used as the main OTDR unit. If the OTDR main unit is other than the MW9076B/C, only the OTDR I/O connector is provided.

A visible LD output connector is provided when the optional visible LD (MW9076B/B1/C/D/D1/J/K-01) is installed.

An optical power meter input connector is provided when the optional optical power meter (MW9076B/B1/C-02, 03) is installed on the MW9076B/B1/C.

### **WARNING** ⚠

**NEVER** look into the cable connecting end of the optical connector of the OTDR or the end of the cable connected to the OTDR. If you do so, the laser light may damage your eyes.

### **CAUTION** ⚠

The OTDR outputs high-power optical pulses. Please disconnect the communication equipments from the optical fibers before measurement in case that the optical sensor breaks.



## 2.8 Connecting Peripheral Units

### 2.8.1 Inserting and removing a memory card

Refer to “Appendix A Peripherals and Parts” for the available memory card.

The SRAM memory card for the MW9070 cannot be used.

A new memory card must be formatted before a file can be saved on it. A new memory card must be formatted with the MS-DOS format before a file is saved on it. (The memory card described in “Appendix A Peripherals and Parts” is formatted at the shipment.) Refer to “Section 7.2.4 Initialize (Format).”

#### Inserting a memory card

The memory card has a cutout to prevent misinsertion. Insert the card so that the cutout is located as shown in the figure on the right. Do not insert a memory card into the slot of the floppy disk drive.

The slot on the front is Drive 1.

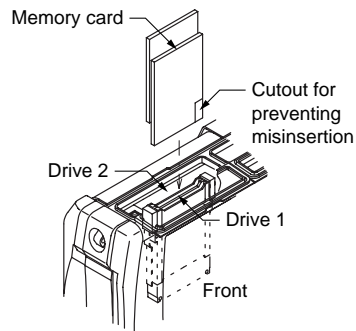

#### Removing a memory card

The memory card can be removed by pressing the eject button as shown in the figure on the right.

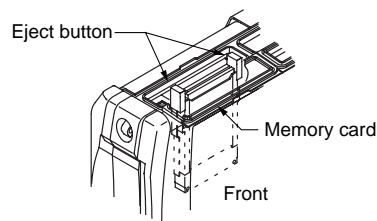

### CAUTION

If this media is mishandled, important data may be lost. To prevent this chance occurrence, all important data and programs should be backed-up.

**Anritsu will not be held responsible for lost data.**

Pay careful attention to the following points. In particular, never remove the ATA memory card from the pulse tester, while it is being accessed.

## 2.8.2 Inserting and removing a floppy disk

A 2HD floppy disk can be used.

A new floppy disk must be formatted before a file can be saved on it. In the IBM format, the capacity is 1.44 Mbytes (18 sectors/track). Refer to “Section 7.2.4 Initialize (Format).”

To save data in a floppy disk, check that the notch of the floppy disk is not set to write protect (WP) before inserting it into the floppy disk drive.

### Inserting a floppy disk

Insert a floppy disk in the direction as shown in the figure on the right.

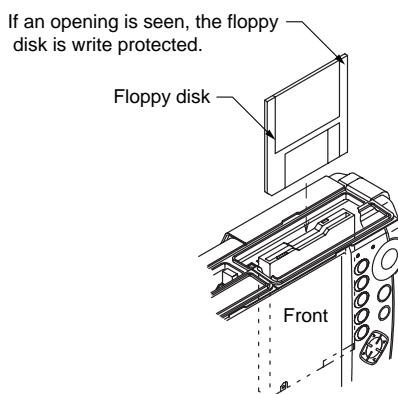

### Removing a floppy disk

The floppy disk can be removed by pressing the eject button as shown in the figure on the right.

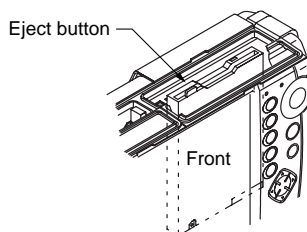

## CAUTION

1. When saving data in a floppy disk or reading data from it, the OTDR must be placed horizontally or inclined using the stand.
2. Use a floppy disk at a temperature of between 5 and 40 °C.
3. Eject the floppy disk from the disk drive before moving the OTDR.
4. Do not keep floppy disks at a location where magnetic fields are present. The data may be destroyed.

### 2.8.3 Connecting an optical channel selector

Either a built-in or external optical channel selector can be controlled. The following channel selectors can be controlled.

	Model name	Number of channels
Built-in	MU960001A	4
Built-in	MU960002A	8
External	MN9662A	8
External	MN9664A	16
External	MN9668A	32

Refer to Appendix A for the details of the built-in optical channel selector.

Refer to the operation manual of each channel selector for the details of the external optical channel selector.

When the main body of MW9076D/D1/J/K OTDR is mounted, a built-in optical channel selector cannot be connected.

#### Installing a built-in optical channel selector

Insert a built-in optical channel selector between the display unit and the OTDR main unit.

The installation and connection procedures of a built-in optical channel selector are explained below.

Refer to “Section 3.3.4 Setting the optical channel selector” for the method of setting the optical channel selector.

- (1) Turn off the power to the OTDR.
- (2) Remove the OTDR main unit. For details, refer to “Section 2.6 Installing and Removing the OTDR Main Unit.”
- (3) Put the optical channel selector on the display unit in such a manner that the connectors of the display unit and the OTDR main unit are aligned. Take care not to damage the connectors during the operation.
- (4) Fasten the four screws for the optical channel selector (see the figure on the next page) using a minus screwdriver.
- (5) Put the OTDR main unit on the optical channel selector in such a manner that the connectors of the optical channel selector and the OTDR main unit are aligned. Take care not to damage the connectors during the operation.
- (6) Fasten the four screws for the OTDR main unit (see the figure on the next page) using a minus screwdriver.

## CAUTION

- Before installing and removing the built-in optical channel selector, make sure to turn off the power. If turned on, the channel selector and the display unit may be damaged.
- Perform the operation with the protective cover attached, or the display unit is damaged.

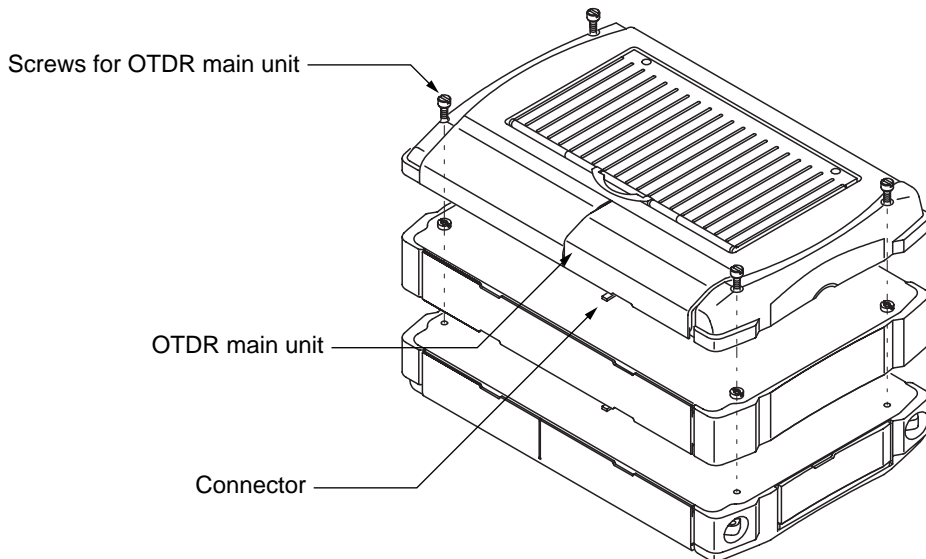
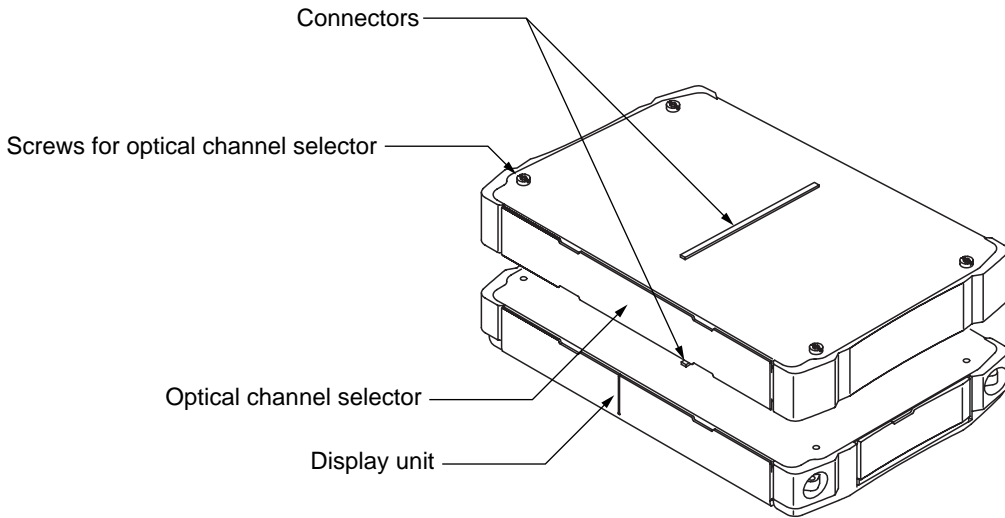

After the completion of the installation of the built-in optical channel selector, connect the OTDR I/O connector and the Com connector of the built-in optical channel selector with an optical fiber as shown in the figure below.

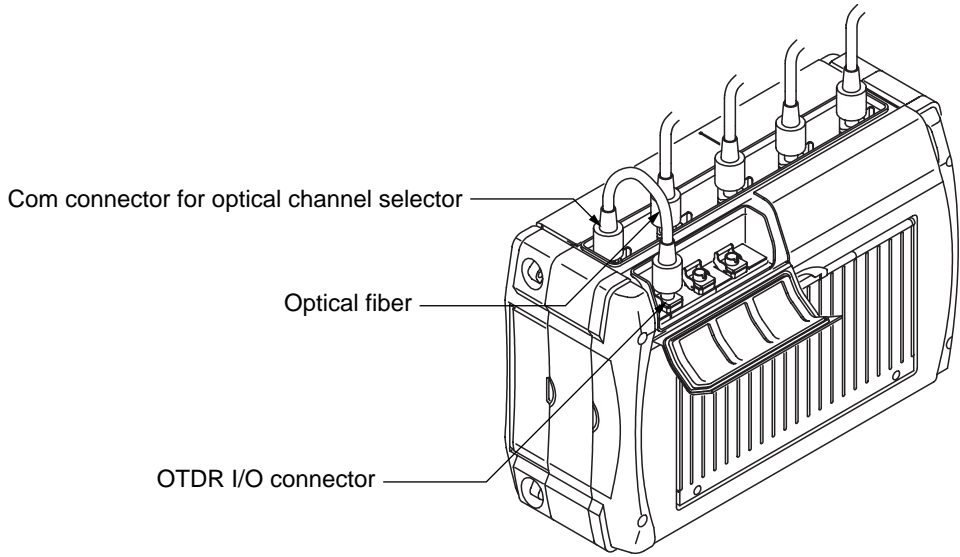

### Connecting an external optical channel selector

An external optical channel selector can be controlled by using Serial Port No. 2 (RS-232C-2) of the OTDR.

The procedure for connecting an external optical channel selector is as follows.

- (1) Turn off the power to the OTDR.
- (2) Connect Serial Port No. 2 (RS-232C-2) of the OTDR to the serial port of the external optical channel selector with a special serial interface cable. Refer to the operation manual of the external optical channel selector for information on the serial port of the external optical channel selector.
- (3) Connect the OTDR I/O connector to the Com connector or the Com1 connector of the external optical channel selector with an optical fiber.

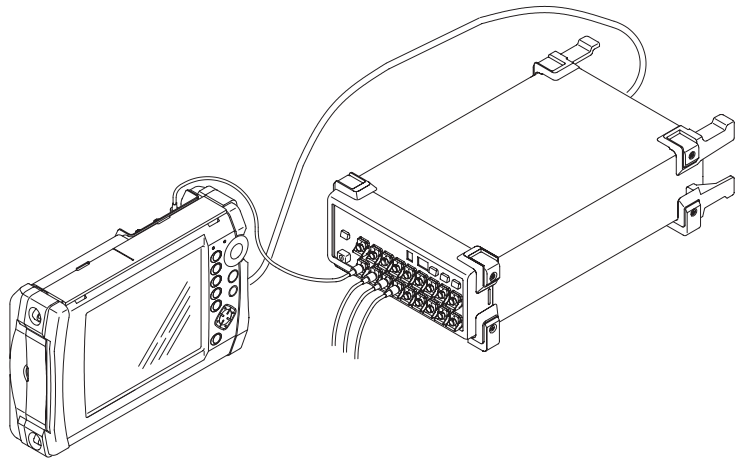

For the method of setting the optical channel selector, refer to “Section 3.3.4 Setting the optical channel selector.” For the serial interface cable, refer to “Appendix A Specifications (14) Peripherals and parts.”

### 2.8.4 Connecting a printer

The OTDR can be connected to a printer through a (D-sub 25-pin) printer port. Connect the OTDR to the printer as shown in the figure below.

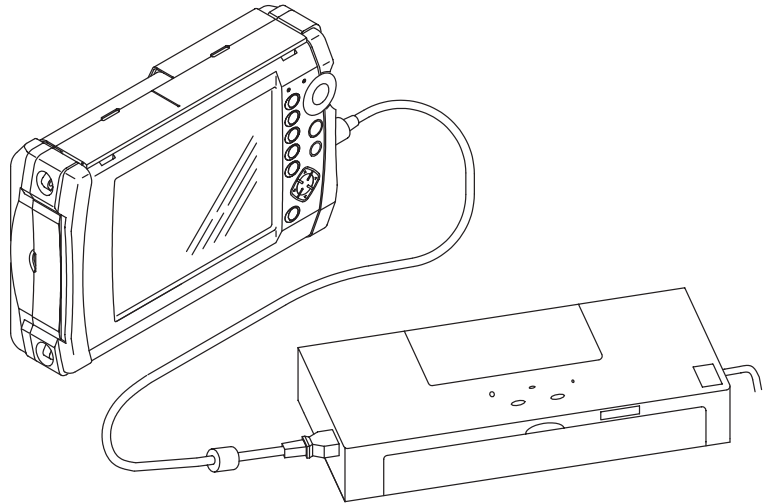

Refer to “Section 3.3.2 Setting the printer” for the printer settings.

The pin arrangement of the printer port is shown below for reference.

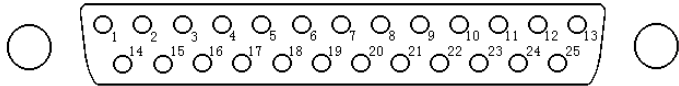

No	I/O	Name	
1	O	STB	Data Strobe
2	O	D0	Paralell Data
3	O	D1	Paralell Data
4	O	D2	Paralell Data
5	O	D3	Paralell Data
6	O	D4	Paralell Data
7	O	D5	Paralell Data
8	O	D6	Paralell Data
9	O	D7	Paralell Data
11	I	BUSY	Busy
12	I	PE	Paper End
15	I	ERROR	Error
18-25	—	SG	Signal Ground
else	—	—	—

## 2.8.5 Connecting a computer

The OTDR can be connected to a computer through a (D-sub 9-pin) RS-232C-1 interface.

Connect the OTDR to the computer as shown in the figure below.

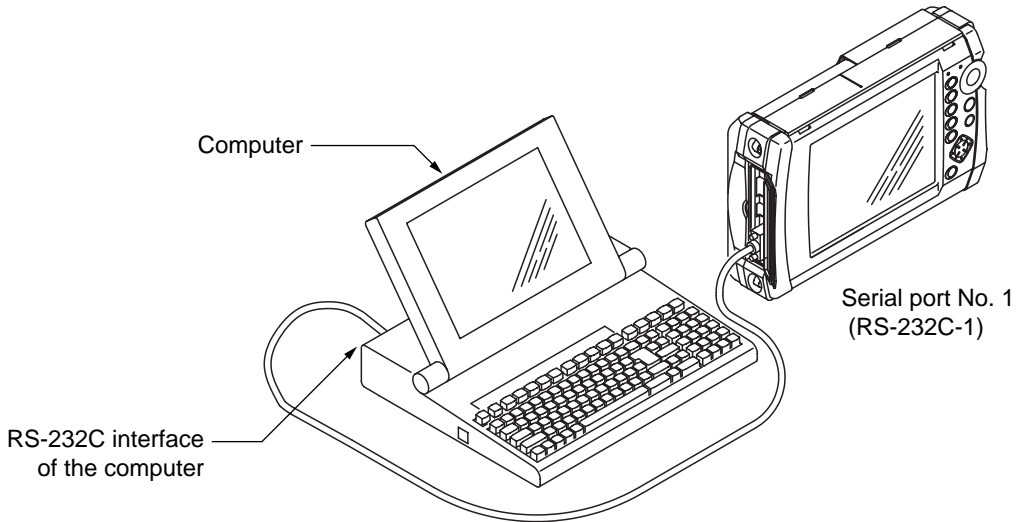

For the setting of Serial Port No. 1 of the OTDR, see “3.3.3 Setting the serial port”.

For the setting of the RS-232C interface on the computer side, refer to the operation manual of the used computer. The OTDR and the computer will not operate properly if their settings do not match

The pin arrangement of Serial Port No. 1 (RS-232C) is shown below for reference.

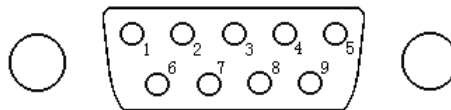

No	I/O	Name	
1	I	DCD (CD)	Carrier Detect
2	I	RXD (RD)	Receive Data
3	O	TXD (SD)	Send Data
4	O	DTR (ER)	Equipment Ready
5	—	SG	Signal Ground
6	I	DSR (DR)	Data Set Ready
7	O	RTS (RS)	Request to Send
8	I	CTS (CS)	Clear to Send
9	—	—	—



## 2.8.6 Connecting an external monitor

The OTDR can be connected to an external monitor through a (mini DIN 10-pin) VGA interface. The VGA conversion cable is required for the connection. (See Appendix A (14) Peripherals and Parts”)

Connect the OTDR to the external monitor as shown in the figure below.

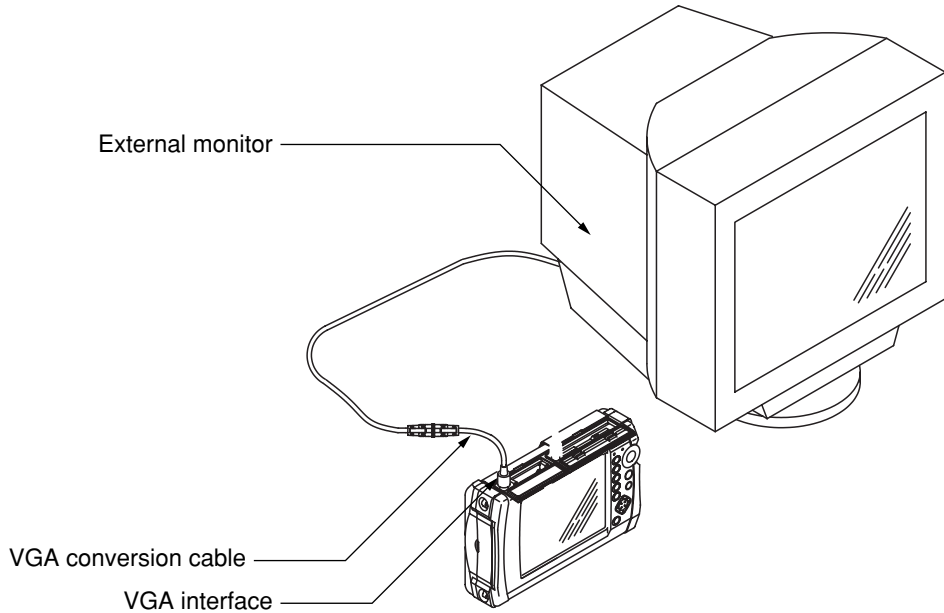

The pin arrangement of the VGA interface is shown below for reference.

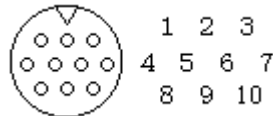

No	Signal name	Function
1	RED	Red, signal line
2	RRTN	Red, return line
3	GREEN	Green, signal line
4	GRTN	Green, return line
5	BLUE	Blue, signal line
6	BRTN	Blue, return line
7	HSYNC	Horizontal synchronous signal
8	GND	Ground
9	VSYNC	Vertical synchronous signal
10	GND	Ground

## 2.8.7 Connecting a keyboard

The OTDR can be connected to a keyboard through a (mini DIN 6-pin) keyboard interface.

Connect the OTDR to the keyboard as shown in the figure below.

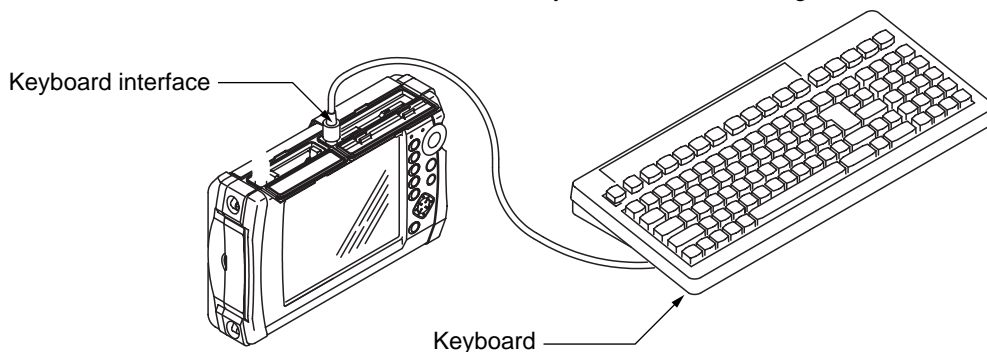

The pin arrangement of the keyboard interface is shown below for reference.

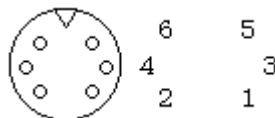

No	Signal name
1	KBDATA (O.D.)
2	MSDATA (O.D.)
3	GND
4	+5 V
5	KBCLK (O.D.)
6	KSCLK (O.D.)

O.D.: Open drain output (+5 V pull up)

### CAUTION

**The keyboard should be connected or disconnected only when the power supply to the equipment is off. The keyboard will not function properly if it is connected or disconnected when the power supply is on.**

#### Keyboard entry

Alphanumeric characters can be entered from the keyboard during the following operations.

Operation from the keyboard cannot be performed except for the following operations.

- File name entry
- Title/header entry
- Event comment entry

## 2.9 Precautions

### Connector cover

The interface connector has a dust-proof cover. Do not remove the cover except when a cable is to be connected to the connector.

### Condensation

If the OTDR is carried from a low-temperature environment to a warm room, there is danger of condensation in it. In this case, allow the OTDR to dry completely before turning on its power.

### Exposure to extremely high temperature in vehicles

Do not leave the OTDR in a vehicle. The ambient temperature may exceed the storage temperature ( $-20\text{ }^{\circ}\text{C}$  or  $+60\text{ }^{\circ}\text{C}$ ) which may result in the failure of the OTDR. Do not expose the OTDR to an extremely high or low temperature.

### Safety

Do not use an AC adapter other than the supplied accessory adapter. If another adapter is used, the OTDR may be damaged because of nonconformity with the required specifications.



# Section 3 Setup and Setting of Peripheral Units

This section explains the items that can be set on the Setup screens and the method of setting these items. It also explains the method of setting peripheral units.  in this section indicates a panel key.

3.1	Setting Method .....	3-2
3.2	Explanation of Setup Screens .....	3-6
3.2.1	Setup screen 1 .....	3-6
3.2.2	Setup screen 2 .....	3-11
3.2.3	Setup screen 3 .....	3-14
3.3	Setting of the Peripheral Units .....	3-16
3.3.1	Setting the system .....	3-16
3.3.2	Setting the printer .....	3-19
3.3.3	Setting the serial port .....	3-21
3.3.4	Setting the optical channel selector ....	3-23
3.3.5	Setting the display on the screen .....	3-24
3.3.6	Setting the color on the screen .....	3-26
3.4	Reading, Saving, and Printing the Settings ...	3-27
3.4.1	Reading the DFN file .....	3-27
3.4.2	Saving the DFN file .....	3-29
3.4.3	Printing the settings .....	3-31
3.5	Preview .....	3-33

The Setup screens are used to set and change the OTDR measurement parameters. They are composed of Setup screen 1 (Setup <1/3>), Setup screen 2 (Setup <2/3>), and Setup screen 3 (Setup <3/3>). Setup screen 1 is always displayed when the OTDR is switched on. By pressing **F1** (setup), the Setup screens can be displayed from any measurement mode to change the measurement conditions.

When the OTDR power is turned off, the measurement conditions set at that time are saved in the OTDR internal memory and the same conditions are read from the memory when the power is turned on the next time. Furthermore, when the measurement conditions have been presaved as a DFN (DeFiNition) file, the standard definition conditions can be recalled simply by reading the DFN file even after various settings have been changed.

**Note:**

The DFN file can be only saved in the OTDR internal memory.

### 3.1 Setting Method

**Setting items**

The cursor can be moved up and down to any item by rotating the rotary knob or by pressing the **^** and **v** keys.

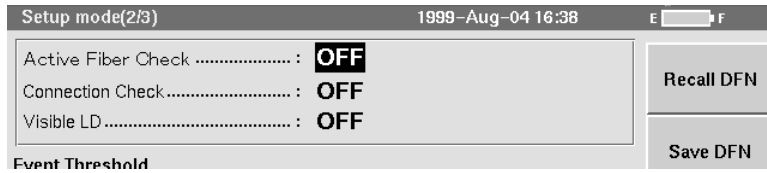

The cursor is moved to the next item by moving the rotary knob clockwise or by pressing the **v** key. (See the figure below.)

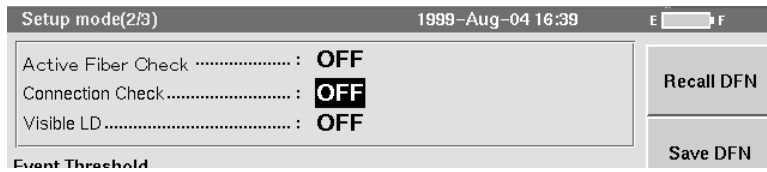

After the cursor can be moved to the target item, enter the item by pressing the center of the rotary knob or by pressing **Select**.

After the setting is completed, move to the setting of measurement conditions (parameters).

### Changing the measurement conditions (parameters)

Some of the measurement conditions can be set by either selecting a parameter from several options (numeric values or words) and by entering a numeric value.

#### Selecting a parameter

When an item is selected, a window showing its options (numeric values or words) is opened.

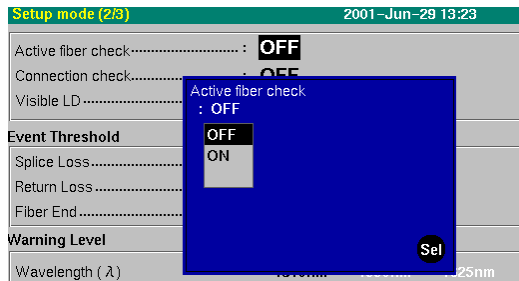

Select the desired value by moving the rotary knob or by moving the  $\wedge$  and  $\vee$  keys. (See the figure below.)

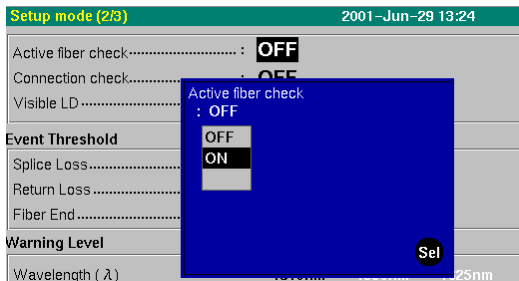

After the cursor is moved to the desired value, enter it by pressing the rotary knob or by pressing **Select**. After the value is entered, the window closes and the setting displayed on the screen is changed to the set value.

**Entering a value**

Some of the measurement conditions can be set either by only entering a numeric value or by entering ON/OFF and a numeric value.

**When entering only a numeric value**

After an item is selected, a window for entering numeric values is opened.

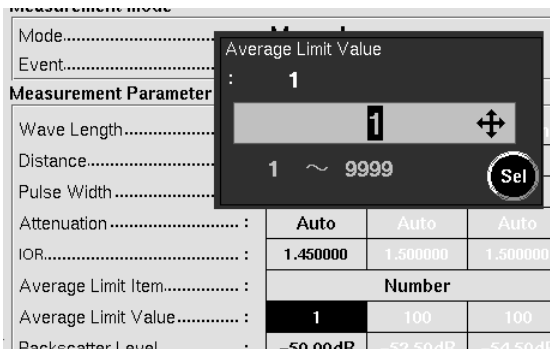

In this state, the value can be changed by +1 (-1) by moving the rotary knob or by pressing the  $\wedge$  ( $\vee$ ) keys.

It is also possible to change the numeric value by entering the numerical digits. If the  $\lt$  key is pressed once in this state in the above figure, the cursor is moved to the second digit. (See the figure below.)

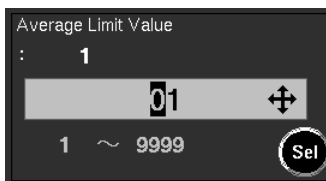

In this state, the value can be changed by +1 (-1) by rotating the rotary knob or by pressing the  $\wedge$  ( $\vee$ ) keys.

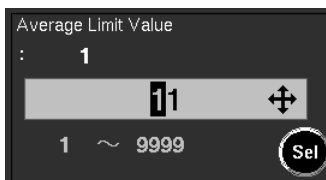



**When ON/OFF and a numeric value is entered.**

After an item is selected, a window for entering the numeric values is opened.

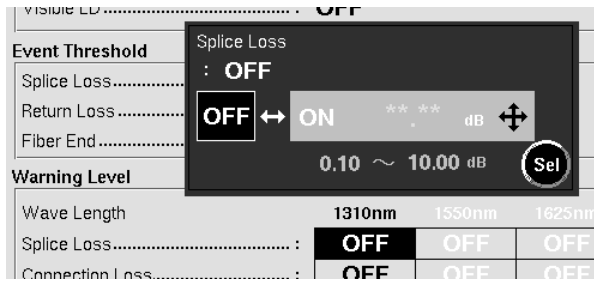

If  $\text{>}$  is pressed in this state, ON is selected and the entry of a numeric value is enabled. (See the figure below.)

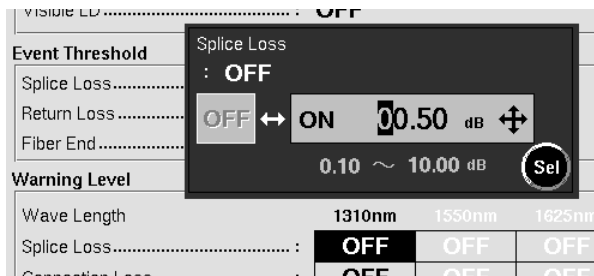

If the  $\text{^}$  and  $\text{v}$  keys are pressed in this state, the value can be changed by +1 (-1). (See the figure below.)

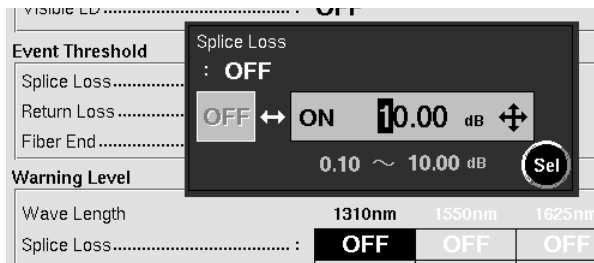

Move the cursor to the desired place by pressing the  $\text{<}$  or  $\text{>}$  key and change the value by pressing the  $\text{^}$  and  $\text{v}$  keys. If the  $\text{<}$  is pressed and held down, OFF is selected.

## 3.2 Explanation of Setup Screens

This section explains each parameter in the Setup screens. The settings at the time of shipment from the factory are explained in “Appendix F Settings at Factory Shipment.”

### 3.2.1 Setup screen 1

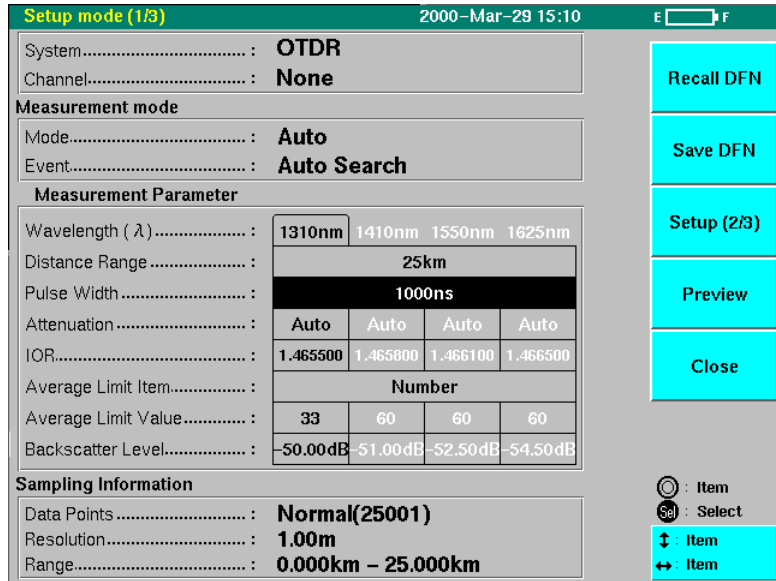

#### System

Select the measurement system (OTDR/OLTS/CD).

The OLTS measurement can be set on the MW9076B/B1/C onto which an optional optical power meter installed. The CD can be set on the MW9076D/D1 by which Chromatic Dispersion measurements can be made.

#### OTDR

Parameter setting and OTDR measurements can be performed.

#### OLTS

The light source and the optical power meter can be set for making total loss measurements.

#### CD

Chromatic Dispersion measurements can be performed.

#### Channel

Set the channel used when a built-in or external optical channel selector is connected. If no optical selector is used, 'None' is displayed.

**Measurement mode****Mode**

Select the measurement mode (Full Auto/Auto/Manual).

**Full Auto**

The distance range (Distance), pulse width (Pulse Width), attenuator (Attenuator), averaging limit (Averaging Limit Item and Value) are set to Auto and auto search is performed.

**Auto**

Input attenuator (Attenuator) is set to Auto and auto search is performed. For other items, the currently set measurement conditions are used.

**Manual**

Measurements are performed for the currently set measurement conditions and splice measurements are made. Although auto search is not performed, the auto marker that places supplementary markers for splice measurement at optimum positions is displayed.

**Event**

Select the event table creation method (Auto Search/Fixed).

**Auto Search**

Auto search is performed again without taking the previous auto search result into consideration.

**Fixed**

An event point near the event point that was detected in the previous auto search is detected.

### Measurement Parameter

#### Wavelength

Switches the measurement wavelength.

Select one, or multiple wavelengths at one time, from installed wavelengths.

Settable wavelengths vary depending on the installed OTDR main unit.

MW9076B/B1: 1310 nm/1550 nm

MW9076C: 1310 nm/1550 nm/1625 nm

MW9076D: 1310 nm/1410 nm/1550 nm/1625 nm

MW9076D1: 1310 nm/1450 nm/1550 nm/1625 nm

MW9076J: 850 nm

MW9076K: 850 nm/1300 nm

When multiple wavelengths are specified, measurement is performed sequentially from shortest to longest.

For example, 1310 nm/1550 nm/1625 nm are specified for MW9076D, wavelengths will be measured from 1310 nm → 1550 nm → 1625 nm.

#### **Note:**

In the CD measurement mode, all installed wavelengths are always selected.

#### Distance

Select the distance range (Auto/1/2.5/5/10/25/50/100/200/250/400 km. Up to 100 km for MW9076J/K.).

If the distance range is set to Auto and  is pressed, the optimal distance range is automatically detected and displayed on the screen. If the total length of the optical fiber is known, select a value slightly greater than the length. The measurement takes a longer time if the selected value is very large. If a length shorter than the fiber length is set, the measured data becomes wrong because the ghosts appear on the accurate waveform.

#### About "Ghost"

A phenomenon that the wrong waveform like Fresnel reflection appears on some points of the accurate waveform where normally no events exist.

This happens when inappropriate distance range is selected.

#### Pulse Width

Select the pulse width

(Auto/10/20/50/100/500/1000/2000/4000/10000/20000 ns. Up to 100 ns/1000 ns for MW9076J/K.).

The shorter the pulse width, the higher the resolution, and the accurate the measurement. On the other hand, the shorter the pulse width, the smaller the power, so that the noise component increases as the fiber cable length increases. If the pulse width is set to Auto and  is pressed, the optimum pulse width is automatically detected and displayed on the screen.

**Attenuation**

Set the attenuator.  
 It is necessary to increase the pulse width for performing measurements with a long fiber cable.  
 However, the increase in pulse width may cause saturation of the near-end of the received wavelength. In this case, it is necessary to insert an attenuator. The available attenuator values depend on the pulse width. If Full-auto or Auto is set in the measurement mode, an optimal attenuator is automatically inserted and it cannot be changed.

**IOR (Index of Reflection)**

Set the index of reflection (1.400000 to 1.699999).  
 When modifying the value in the IOR setting dialog, the displayed values of the selection marker position or the selection event distance are automatically changed.

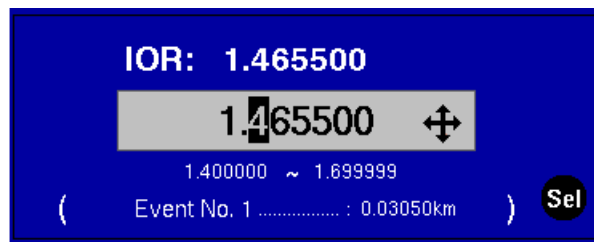

**Average Limit Item**

Select the average count mode (Auto/Number/Time)

Measurement mode	Average Limit Item
Full Auto	Cannot be set
Auto	Auto/Number/Time
Manual	Number/Time

**Auto**

The number of times and the time are set automatically.

**Number**

The number of averaging is set and the specified data points are averaged.

**Time**

The time is set and the data collected during the specified time is averaged.

**Average Limit Value**

Set the number of averaging or time (1 to 9999 times or seconds).  
 If Average Limit Item is set to Auto, \*\*\* is indicated as the Average Limit Value and no value can be set.

**Back scattering level**

Enter a corrected value (-9.99 to +9.99 dB) of the back scattering level.  
 The backscatter level is a constant number used for calculating the return loss and total return loss.

## Section 3 Setup and Setting of Peripheral Units

### Sample Information

#### Data points

Select the number of sampling points (Quick/Normal/High).

The actual number of sampling points is determined by the settings of the distance range (Distance) and Quick/Normal/High. The relationships between them are explained in Sampling Resolution (Resolution).

#### Resolution

Display the sampling resolution.

The maximum values of the sampling resolution (Resolution) depending on the distance range (Distance) and the number of sampling points (Data Points) are shown below.

Distance range	Sampling points		
	Quick	Normal	High
1 km	20 cm (5001)	5 cm (20001)	Cannot be set
2.5 km	50 cm (5001)	10 cm (25001)	5 cm (50001)
5 km	1 m (5001)	20 cm (25001)	10 cm (50001)
10 km	2 m (5001)	50 cm (20001)	20 cm (50001)
25 km	5 m (5001)	1 m (25001)	50 cm (50001)
50 km	10 m (5001)	2 m (25001)	1 m (50001)
100 km	20 m (5001)	5 m (20001)	2 m (50001)
200 km	40 m (5001)	10 m (20001)	5 m (40001)
250 km	40 m (6251)	10 m (25001)	5 m (50001)
400 km	80 m (5001)	20 m (20001)	10 m (40001)

The number in parentheses indicates the number of sampling points.

When the multiple wavelengths are set, High cannot be set.

The marker resolution is also determined by the range of the horizontal scale indication and the sampling resolution on the screen. The distance of shift at every click on the marker during the manual measurement is determined by the marker resolution. (See Appendix H.)

#### Range

Indicates the sampling range.

The range determined automatically by the sampling resolution is displayed. The sampling range cannot be set on the Setup screen.

## 3.2.2 Setup screen 2

**Setup mode (2/3)** 2000-Mar-29 14:51 E F

Active fiber check..... : **OFF**  
 Connection check..... : **OFF**  
 Visible LD..... : **OFF**

**Event Threshold**

Splice Loss..... : **+0.30dB**  
 Return Loss..... : **+25.0dB**  
 Fiber End..... : **+5.0dB**

**Warning Level**

Wavelength ( $\lambda$ )	1310nm	1410nm	1550nm	1625nm
Splice (Non Ref.)..... [dB] :	OFF	OFF	OFF	OFF
Splice (Reflect)..... [dB] :	OFF	OFF	OFF	OFF
Return Loss..... [dB] :	OFF	OFF	OFF	OFF
Fiber Loss..... [dB/km] :	OFF	OFF	OFF	OFF
Total Loss..... [dB] :	OFF	OFF	OFF	OFF
Total Return Loss..... [dB] :	OFF	OFF	OFF	OFF
Average Loss..... [dB/km] :	OFF	OFF	OFF	OFF

Recall DFN  
 Save DFN  
 Setup (3/3)  
 Preview  
 Close

⊙ : Item  
 ⊗ : Select  
 ↓ : Item  
 ↔ : Item

**Active fiber check**

Set whether to check for communication light in the fiber under test before the OTDR sends a light pulse.

ON: Check is made.

OFF: Check is not made.

If communication light is detected as a result of the check, the OTDR displays a message, and then stops the measurement.

**Connection check**

Set whether to check the connection status of the fiber under test to the OTDR.

ON: Check is made.

OFF: Check is not made.

If any abnormality is detected in the connection status as a result of the check, the OTDR displays a mark on the top right-hand side of the screen.

**Visible LD**

Set the output status of the optional visible LD. If a visible LD is not installed, it is not displayed.

ON: Light is emitted.

OFF: Light is not emitted.

Blink: Blinks with a 50% duty cycle of 0.25 seconds.

If Visible LD is set to ON or Blink, red light is emitted. If the cursor is moved to another item or to another screen, it is automatically set to OFF.

Since this red light is visible, abnormalities in the optical fiber can be visually detected. However, this light cannot be used for measuring the loss or for detecting event points.

## WARNING

**Never look into the optical connector of the OTDR nor the end of the cable connected to the OTDR. If you do so, the laser light may damage your eyes.**

**Caution - use of controls or adjustment or performance of procedures other than those specified herein may result in hazardous radiation exposure.**

The following sub-window is displayed when the Visible LD is set to ON.

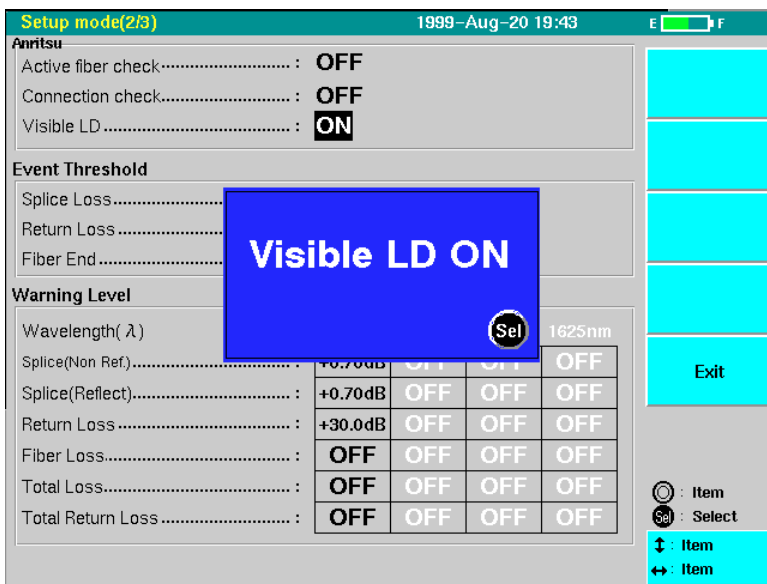



**Event Threshold**

**Splice Loss** A point that indicates a splice loss greater than the set value is set as an event (fault).

The set value is between 0.01 and 9.99 dB in steps of 0.01 dB.

**Return Loss** A point that indicates a return loss greater than the set value is set as an event (fault).

The set value is between 20.0 and 60.0 dB in steps of 0.1 dB.

**Fiber End** A point that indicates a loss greater than the set value is set as the fiber far end.

The set value is between 1 and 99 dB in steps of 1 dB.

**Warning Level**

**Wavelength** Indicates the measured wavelength. It cannot be selected on this screen. Refer to Wavelength on “Section 3.2.1 Setup screen 1.”

**Splice (Non Ref.)** Set the warning indication function after the measurement result is evaluated.

**Splice (Reflect)** Set the warning indication ON/OFF for each item and the threshold when ON is specified. Select either “Return Loss” or “Height”.

**Return Loss** Refer to the Reflective Type in “3.3.5 Setting the display on the screen.”

**Height** The evaluation items and the threshold setting range for each item are shown below

**Fiber Loss**

**Total Loss**

**Total Return Loss**

**Average loss**

Measured item	Threshold setting range
Splice (Non Ref.)	0.10 to 10.00 dB (0.01 Step)
Splice (Reflect)	0.10 to 10.00 dB (0.01 Step)
Return Loss	60.0 to 20.0 dB (0.1 Step)
Height	1.0 to 20.0 dB (0.1 Step)
Fiber Loss	0.01 to 10.00 dB/km (0.01 Step)
Total Loss	0.1 to 60.0 dB (0.1 Step)
Total Return Loss	50.0 to 10.0 dB (0.1 Step)
Average Loss	0.01 to 10.00 dB/km (0.01 Step)

Splice (Non Ref.): Splice of event table. Events of No Reflect type is the object.

Splice (Reflect): Splice of event table. Events of Reflect type is the object.

Return Loss: Return Loss of event table is the object.

Height : Height of event table is the object.

Fiber Loss: dB/km of event table is the object.

Total Loss: Total Loss as the result of the search on the top right-hand side of the screen.

Total Return Loss: Total Return Loss as the result of the search on the top right-hand side of the screen.

Average loss: The average loss as the result of the search on the top right-hand side of the screen.

### 3.2.3 Setup screen 3

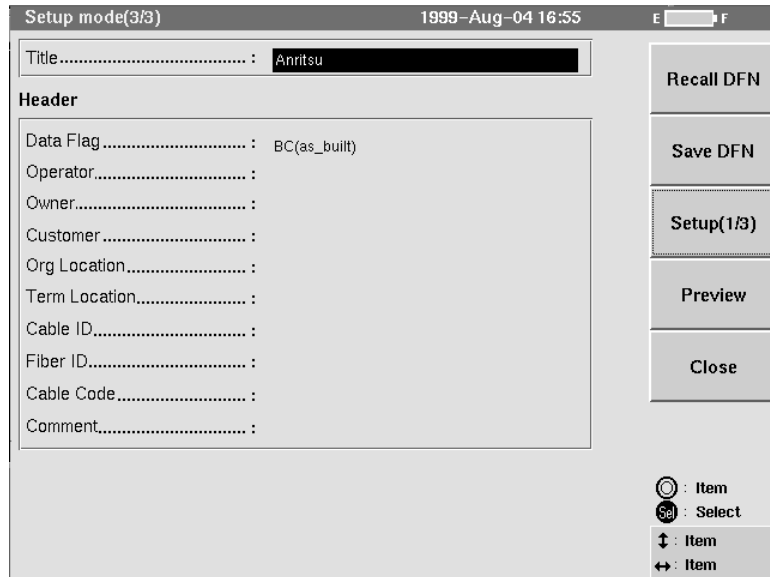

**Title**

The title set here is displayed on the top of the screen displaying the trace waveform. Up to 32 characters can be displayed.

The string displayed in this title field is already entered.

**Method of entering a title**

The title input window is opened if Title is selected on the print setting screen.

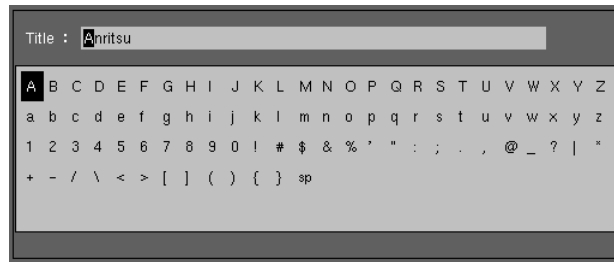

Move the cursor to the desired location using the < and > keys.

Select the desired character with the rotary knob.

After entry is completed, press F5 (Close).

The selected characters are entered and displayed next to the Title.

**Header**

The headers entered here is printed or saved in a file. Up to 32 characters (one line) can be entered. For comments, up to 64 characters (32 characters × 2 lines) can be entered.

Both the title and the header exceed the displaying if the wide characters are used and they cannot be displayed.

**Data Flag****Operator****Owner****Customer****Org Loc****Term Loc****Cable ID****Fiber ID****Cable Code****Comment**

Select the Data Flag from the following.

BC (as\_built) : During installation

RC (as\_repair) : During repair

OT (other) : Other

If a header other than Data Flag is selected, the header input window (as in the title input) is opened. Select the characters to be set.

Refer to “Method of entering a title” for the details of character input.

## 3.3 Setting of the Peripheral Units

### 3.3.1 Setting the system

Set the OTDR system.

Each setting is fixed when the System Setting Screen shown in the figure below is closed by pressing **F5** (Close). Note that pressing **Start** in the state shown in the figure below causes the screen to return to the state prior to modification.

Press **Menu** and select Configuration by pressing **∇**. The following display appears.

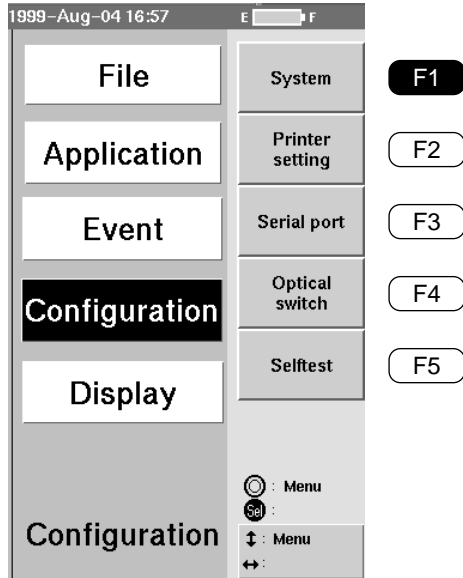

Press **F1** (System). The system setting screen is displayed. (See the figure below.)

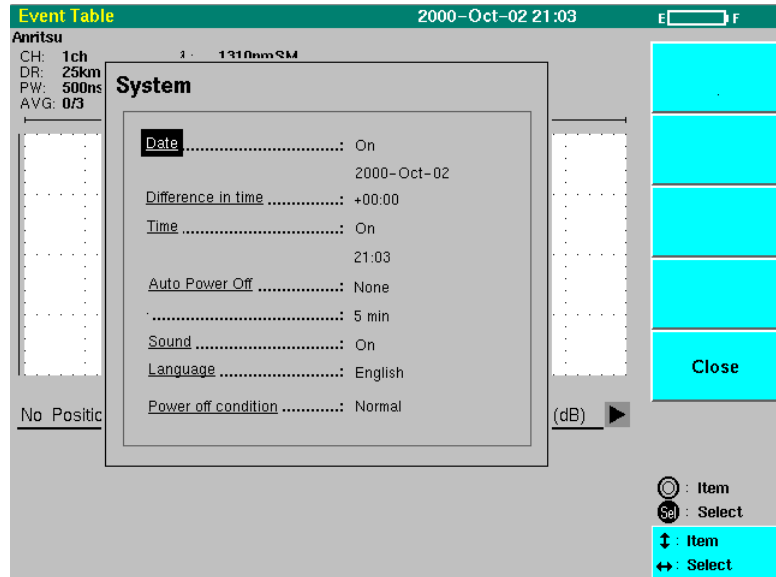

- Date**
- Set whether to display the date, display format, and the date.
- On: The date is displayed at the upper right of the screen. The date is printed when printing is done.
  - Off: The date is not displayed on the screen. The date is not printed when printing is done.
- Set the display format of the date using the function key.
- D-M-Y: Day, month, and year are displayed in this order.
  - M-D-Y: Month, day, and year are displayed in this order.
  - Y-M-D: Year, month, and day are displayed in this order.
- To change the date, move the cursor to the place to be changed and set a new value.
- Difference in time**
- Set the difference in time between the places where this equipment is used. OTDR uses this information only when it saves or recalls a waveform data with Standard, or Standard.V2 file format. (See 7.2.1 “Save” for more information about file type.)
- The local time set in the “Time” section does not change after setting the difference in time. For example, Set “+5:00” when using in New York.
- Time**
- Set whether to display the time.
- On: The time is displayed at the upper right of the screen. The time is printed when printing is done.
  - Off: The time is not displayed on the screen. The time is not printed when printing is done.
- To change the time, move the cursor to the place to be changed and set a new value.
- Auto Power Off**
- Set the elapsed time of the auto power off function that turns off the power automatically if the specified time has elapsed after the last key input.
- 3min: The power is turned off automatically if three minutes have elapsed after the last key input.
  - 5min: The power is turned off automatically if five minutes have elapsed after the last key input.
  - 15min: The power is turned off automatically if 15 minutes have elapsed after the last key input.
  - 30min: The power is turned off automatically if 30 minutes have elapsed after the last key input.
  - None: The auto power off function is not set. The backlight does not become dark or turn off.
- Auto Power Off is always idle in the remote controlled state.

## Section 3 Setup and Setting of Peripheral Units

### Auto Backlight Off

Set the elapsed time of the auto backlight off function that turns off the backlight of the screen automatically if the specified time has elapsed after the last key input.

3min: The back-light becomes dark automatically if three minutes have elapsed after the last key input.

5min: The back-light becomes dark automatically if five minutes have elapsed after the last key input.

15min: The back-light becomes dark automatically if 15 minutes have elapsed after the last key input.

30min: The back-light becomes dark automatically if 30 minutes have elapsed after the last key input.

None: The auto backlight off function is not set. The back-light does not become dark.

However, it is turned off when MU250000A1 is mounted.

### Returning from Auto Backlight Off

To return from Auto Backlight Off, move any key or rotary knob. Only the first entry enables a return to the state prior to Auto Backlight Off. No operations concerning OTDR measurement takes place in this case.

Example: Pressing **Start** while in Auto Backlight Off

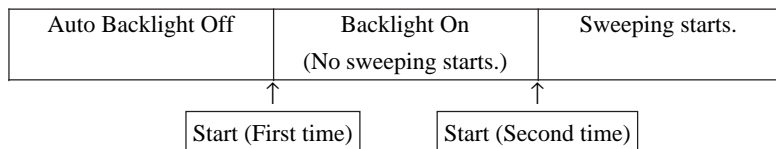

### Sound

Set whether the buzzer should be sounded when a key is pressed or when an error occurs.

On: Buzzer is sounded.

Off: Buzzer is not sounded.

### Language

Switches the language of the displayed screen. However, an option for other language display can be required to be purchased beforehand for other language.

We plan to increase the number of languages to be covered one after another.

Press **F5** (Close) after language selection to close the System Setup screen.

This switches the language to be displayed.

### Power off condition

Sets items to be saved when power is turned off.

The saved measurement conditions are restored the next time power is turned on.

Normal:

Saves all the measurement conditions for Setup.

All Data:

Marker position and waveform data are saved in addition to the measurement conditions for Setup.

### 3.3.2 Setting the printer

Set the printer type connected to the OTDR. A printer can be connected only to the printer port of the OTDR.

Press **Menu** and select Configuration by pressing **V**. The following display appears.

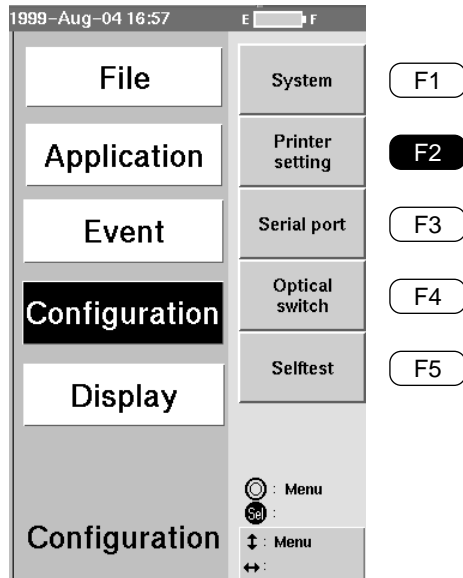

Press **F2** (Printer Setting). The printer setting screen is displayed. (See the figure below.)

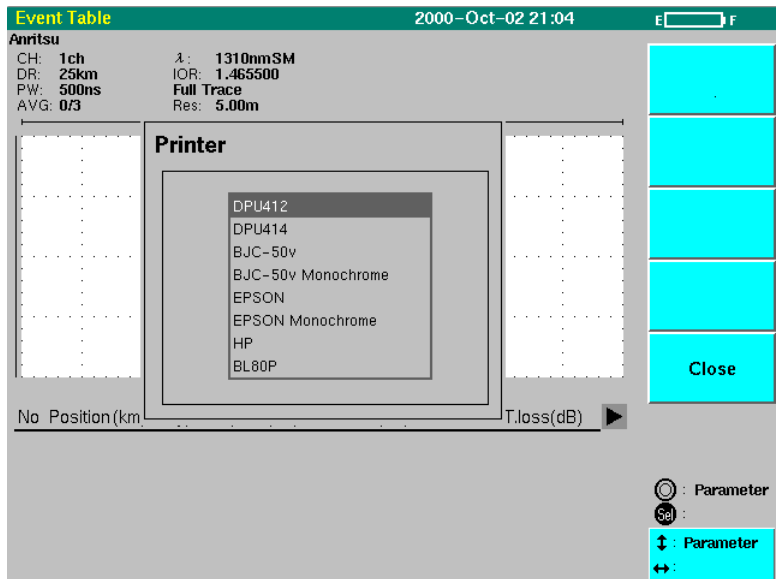

Select one of the printer types displayed on this screen by moving the cursor. If **F5** (Close) is pressed in the selected state, the selected printer type is entered.

See “Appendix G List of Recommended Printers” for more information on the types of printers enabled to be used.

### Section 3 Setup and Setting of Peripheral Units

---

When connecting the DPU-412 Thermal printer (Seiko Instruments), set the rear dip switches as shown below. When shipped from Anritsu, they are set as below and thus do not need to be changed.

**Dip switches 1**

	1	2	3	4	5	6	7	8
ON	<input type="checkbox"/>		<input type="checkbox"/>				<input type="checkbox"/>	<input type="checkbox"/>
OFF		<input type="checkbox"/>		<input type="checkbox"/>	<input type="checkbox"/>	<input type="checkbox"/>		

**Dip switches 2**

	1	2	3	4	5	6	7	8
ON						<input type="checkbox"/>	<input type="checkbox"/>	
OFF								

Switches 1 to 5 and 8 are not used.



### 3.3.3 Setting the serial port

Set the serial port (RS-232C) of the OTDR. The OTDR has two serial ports. Port No. 1 is used to control the OTDR externally by connecting to an external computer. Port No. 2 is used to control an external device from the OTDR by connecting the OTDR to an external device.

Press **Menu** and select Configuration by pressing **V**. The following display appears.

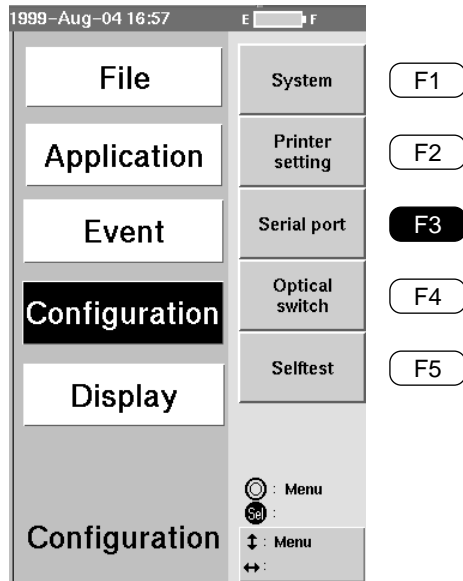

Press **F3** (Serial Port). The serial port setting screen is displayed. (See the figure below.)

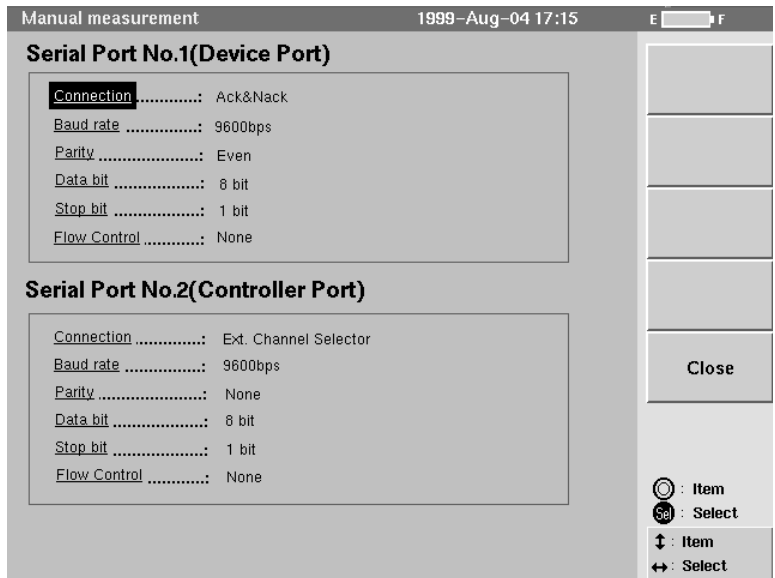

### Section 3 Setup and Setting of Peripheral Units

---

#### Connection

Set the format of the data to be transferred.

ACK&NACK: Transmit control code is added before and after the data to be transferred.

Direct: Only the data to be transferred is sent.

Refer to “MW9076 Series Serial Interface Operation Manual” for the details.

Serial Port No.2 is set whether it is used for the external channel selector.

It is used for the external channel selector, match the setting of connected channel selector and the contents of the following items.

Do not set Flow Control.

#### Baud rate

Set the data transfer rate.

9600 bps, 19200 bps, 38400 bps, 57600 bps, or 115200 bps can be set.

For Port No. 2, up to 57600 bps can be set.

#### Parity

Set the method of parity check of the data to be transferred.

Odd: Odd parity

Even: Even parity

No: Parity check is not made.

#### Data bit

Set the bit length of the data to be transferred.

5 bits, 6 bits, 7 bits, or 8 bits can be set.

However, for Serial Port No.1, only 8 bits can be set.

#### Stop bit

Set the stop bit of the data to be transferred.

1 bits or 2 bits can be set.

#### Flow Control

Set the transfer control method during data transfer.

Xon/Xoff: Software Control

(However, it cannot be set in Serial Port No.1.)

Hardware: Hardware control

None: Data is transferred without transfer control.

Press F5 (Close) after the modification of each value to fix the value.

### 3.3.4 Setting the optical channel selector

When the external optical channel selector is used, Serial Port No.2 should be set previously. Refer to “3.3.3 Setting the serial port” how to set.

Set the type of the optical channel selector as built-in or connected to the OTDR. Press **Menu** and select Configuration by pressing **∇**. The following display appears.

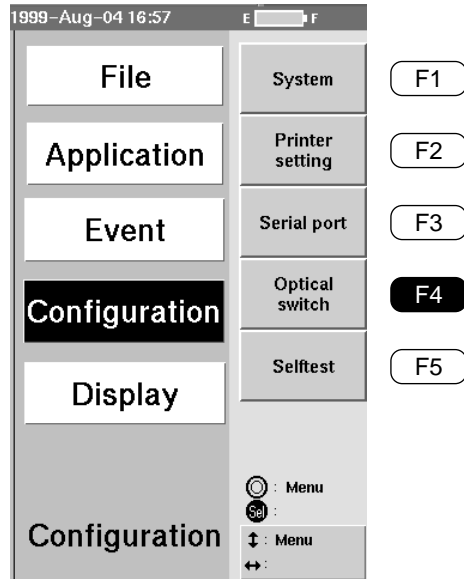

Press **F4** (Optical Switch). The optical channel selector setting screen is displayed. (See the figure below.)

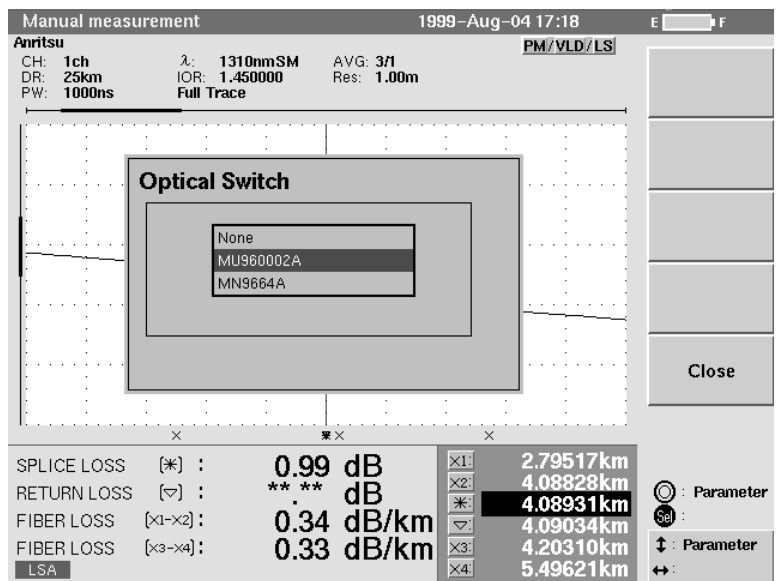

Place the cursor over the name of the optical channel selector type. The selected optical channel selector type name can be entered by pressing **F5** (Close) with the cursor placed over it.

‘None’ is displayed if the optical channel selector is not connected.

### 3.3.5 Setting the display on the screen

Set the data of the waveform to be displayed on the measurement screen.

Press **Menu** and select Display by pressing **√**. The following display appears.

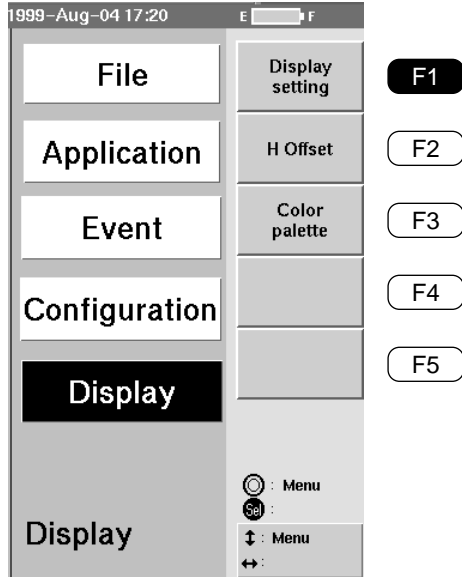

Press **F1** (Display Setting). The screen display setting screen is displayed. (See the figure below.)

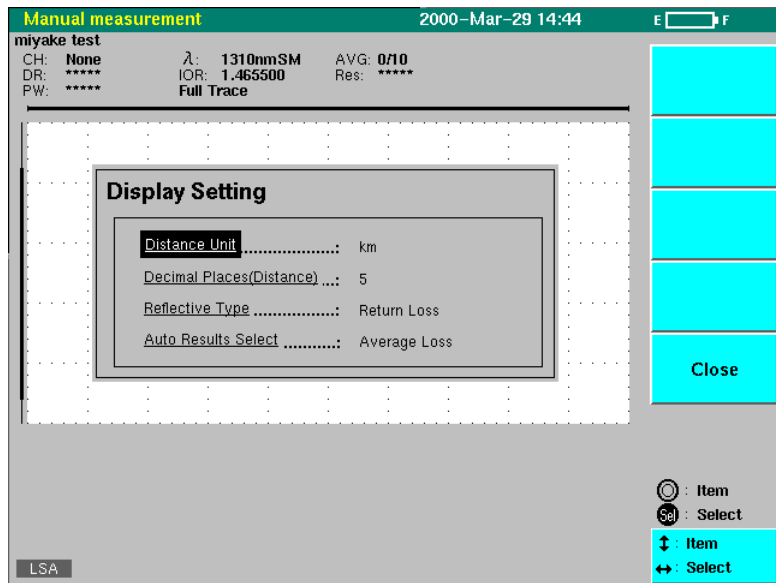

**Distance Unit**

Set the unit displayed on the measurement screen. If the unit is set here, all units displayed on the screen are changed.

m, km, feet, kfeet, or mile can be set.

$$1 \text{ feet} = 0.3048 \text{ m}$$

$$1 \text{ mile} = 1609.3 \text{ m}$$

**Reflective type**

Set whether the reflectance (Height) or the return loss is measured at the time of return loss measurement.

See “1.3 Loss and Total Return Loss Measurement and Splice & Return Loss Measurement” and “1.4 Reflection Measurement” for more information on the reflection and return loss.

Return loss: The return loss is measured.

Height: The reflectance (the difference between \* and ∇ markers) is measured.

**Decimal Places (Distance)**

Set the number of digits representing the distance to be displayed on the Measurement Screen. Setting the number of digits here changes all the display digits on the screen.

Up to three decimal places (down to the digit of 1 m or 1 feet) or five decimal places (down to the digit of 1 cm or 0.01 feet) are able to be set. However, when unit of distance are set to m or feet, the value is displayed up to 1 cm or 0.01 feet digits regardless of the digit setting.

Examples

Three digits

Five digits

×1:	2.769km	×1:	2.81474km
×2:	4.048km	×2:	4.04299km
*:	4.053km	*:	4.09417km
∇:	4.058km	∇:	4.14534km
×3:	4.166km	×3:	4.19652km
×4:	5.445km	×4:	5.47595km

**Auto result select**

Select one auto result display (loss) at the right top of the Measurement Screen - Average Loss (=Total Loss/Fiber Length) or Total Return Loss.

### 3.3.6 Setting the color on the screen

Set the screen color.

Press **Menu** and select Display by pressing **∇**. The following display appears.

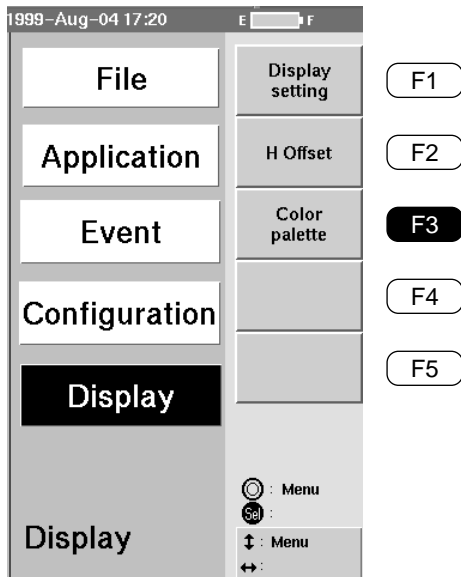

Press **F3** (Color Palette). The color palette screen is displayed. (See the figure below.) Select the item to be set and select the color.

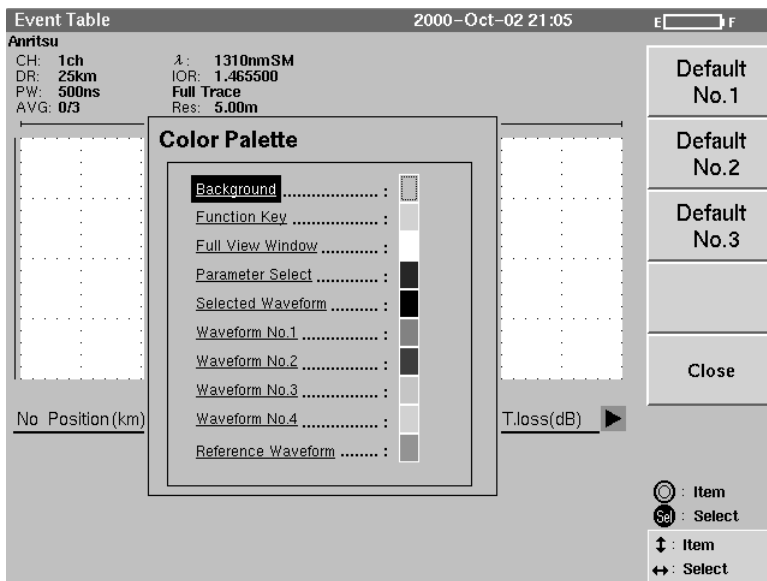

This device has three types of default settings.

Press **F1** , **F2** or **F3** to set each default color.

## 3.4 Reading, Saving, and Printing the Settings

When the power is turned off, the settings are saved in the OTDR internal memory. When the power is turned on again, these saved settings are recalled.

The settings can also be saved in the file of four types. This file is called the DFN file. At the time of factory shipment, the values described in “Appendix F Settings at Factory Shipment” are set. If frequently used standard measurement settings are written to this file, the settings can be reverted to the standard ones by recalling this file after measurements are made while changing the settings. However, note that the settings of the chromatic dispersion measurement cannot be saved into a DFN file.

### 3.4.1 Reading the DFN file

If the measurement parameters have been saved in the DFN file, they can be recalled from any of Setup screens 1 to 3. The method of recalling the DFN file from Setup screen 1 is explained below.

The screenshot shows the 'Setup mode (1/3)' screen with the following parameters and controls:

System.....	OTDR			
Channel.....	None			
<b>Measurement mode</b>				
Mode.....	Auto			
Event.....	Auto Search			
<b>Measurement Parameter</b>				
Wavelength (λ).....	1310nm	1410nm	1550nm	1625nm
Distance Range.....	25km			
Pulse Width.....	1000ns			
Attenuation.....	Auto	Auto	Auto	Auto
IOR.....	1.465500	1.465800	1.466100	1.466500
Average Limit Item.....	Number			
Average Limit Value.....	33	60	60	60
Backscatter Level.....	-50.00dB	-51.00dB	-52.50dB	-54.50dB
<b>Sampling Information</b>				
Data Points.....	Normal(25001)			
Resolution.....	1.00m			
Range.....	0.000km – 25.000km			

On the right side of the screen, there is a vertical sidebar with the following function keys: Recall DFN, Save DFN, Setup (2/3), Preview, Close, and a legend for Item (F1), Select (F2), Item (F3), and Item (F4).

If **F1** (Recall DFN) is pressed when Setup screen 1 is displayed, the function key labels are changed as shown on the next page.

If the function names are already registered, the function names are displayed on the function key labels.

### Section 3 Setup and Setting of Peripheral Units

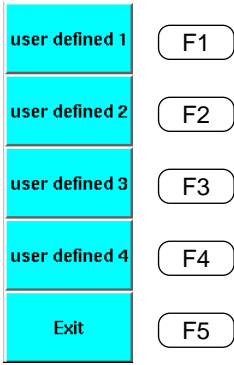

The function key label display on the left is in a state where the function names are not registered when the DFN file is saved. (For the registration of a function name, refer to “Section 3.4.2 Saving the DFN file.” If a function name is registered, the function name is displayed on each function key label.

From **F1** to **F4** (User Defined 1 to 4), select the DFN file to be recalled.

If anyone of the keys **F1** to **F4** is pressed, the function key labels are changed as shown below.

If **F5** (Exit) is pressed, the function key labels return to the state shown on the previous Setup screen.

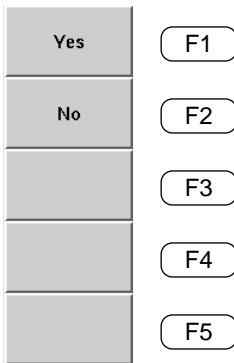

If any of the User Defined keys 1 to 4 is selected, the function keys on the left are displayed and the confirmation message “Recall user defined measurement condition. OK?” is displayed.

To recall the selected DFN file and set it to the OTDR, press **F1** (Yes). After the setting is completed, Setup screen 1 appears again. (Even if a DFN file is recalled from Setup screen 2 or 3, Setup screen 1 is displayed.)

If **F2** (No) is pressed in this state, the recall of DFN file is stopped and returns to the Setup screen.



### 3.4.2 Saving the DFN file

This section explains the method of saving the DFN file. It can be saved from any of the Setup screens 1 to 3. The method of saving the DFN file from Setup screen 1 is as follows.

The screenshot shows the 'Setup mode (1/3)' screen with the following parameters and controls:

- System:** OTDR
- Channel:** None
- Measurement mode:** Mode: Auto, Event: Auto Search
- Measurement Parameter:**

Wavelength (λ)	1310nm	1410nm	1550nm	1625nm
Distance Range	25km			
Pulse Width	1000ns			
Attenuation	Auto	Auto	Auto	Auto
IOR	1.465500	1.465800	1.466100	1.466500
Average Limit Item	Number			
Average Limit Value	33	60	60	60
Backscatter Level	-50.00dB	-51.00dB	-52.50dB	-54.50dB
- Sampling Information:** Data Points: Normal(25001), Resolution: 1.00m, Range: 0.000km – 25.000km
- Function Keys:** Recall DFN, Save DFN, Setup (2/3), Preview, Close
- Navigation:** Item (F5), Select (F6), Item (F7), Item (F8)

If **F2** (Save DFN) is pressed when the Setup screen 1 is displayed, the function key labels are changed as shown below.

If a function name is already registered, the function name is displayed on the function key label.

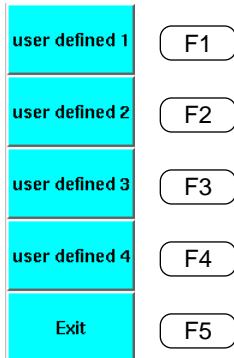

The function key label display on the left is in a state where the function names are not registered.

From **F1** to **F4** (User Defined 1 to 4), select the DFN file to be saved. If any one of the keys **F1** to **F4** is pressed, the function key labels input screen is opened, and plain function key labels can be input.

Up to 20 characters and 1 line can be used for as a function name. However, it cannot be input if the broad fonts are used.

When the function key labels input screen is closed, the function key labels are changed to the display of the next page.

If **F5** (Exit) is pressed, the function key labels return to the state shown on the previous Setup screen.

**Section 3 Setup and Setting of Peripheral Units**

---

Yes	F1
No	F2
	F3
	F4
	F5

If the function key labels input screen is closed, the function keys on the left are displayed. When **F1** (Yes) is pressed, it is saved as a DFN file, and the function labels return to the state shown on the Setup screen.

If **F2** (No) is pressed in this state, the saving of DFN file is stopped and returns to the Setup screen.

### 3.4.3 Printing the settings

This section explains the method of printing the settings assuming that the printer is connected to the OTDR as described in “Section 3.3.2 Setting the printer.”

Press **Menu**. The following display appears.

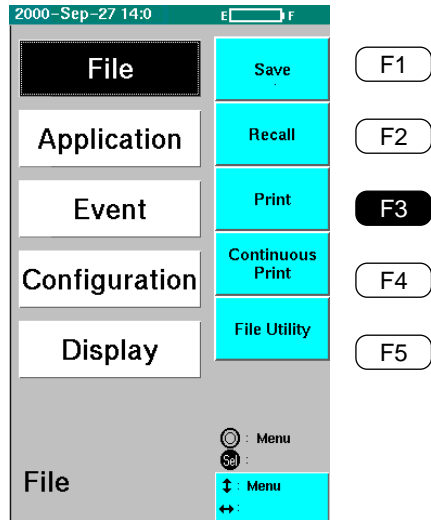

Press **F3** (Print). The printed setting screen is displayed. (See the figure below.)

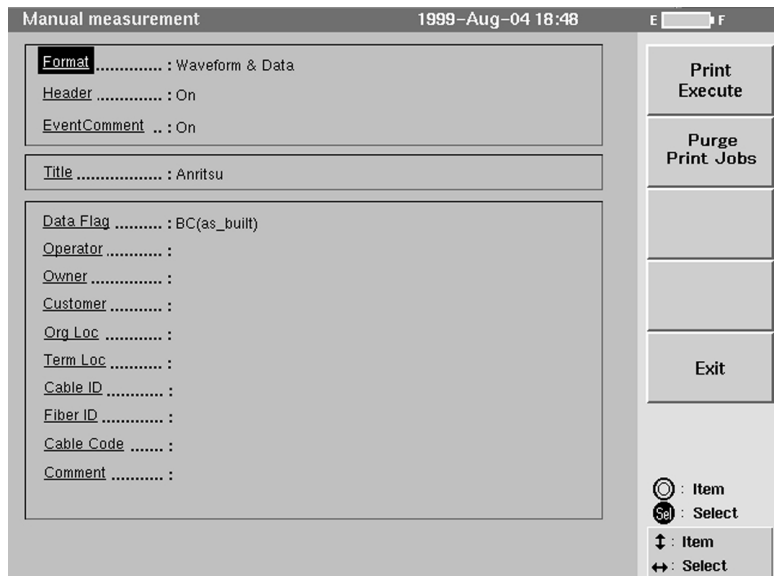

### Section 3 Setup and Setting of Peripheral Units

**Format** Set the data to be printed. Select Setup to print the settings.

Waveform & Data: The waveform data and measurement results are printed.

Data: Only the measurement results are printed.

Setup: The settings on the setup screen are printed.

Waveform, Data and Reference Waveform: In the waveform comparison mode for MW9076, the current and reference waveform data are printed. When this item is specified at normal OTDR or CD measuring, the same contents as when “Waveform and Data” is set are printed.

**Header** Set whether to print the headers under Data Flag.

On: Printed

Off: Not printed.

**Event Comment** Set whether to print the event comment set in the event.

On: Printed

Off: Not printed.

**Title** The title displayed at the upper left of the screen can be entered. The currently displayed string is already set. See how to input the title in “3.2.3 Setup Screen 3” for the method of setting the title.

**Data Flag** Set the header.

**Operator**

**Owner**

**Customer**

**Org Loc**

**Term Loc**

**Cable ID**

**Fiber ID**

**Cable Code**

**Comment**

```

Title      Anritsu                               Date 1999-Aug-09 22:19
Setup
System ..... OTDR
Channel ..... None
Measurement mode
Mode ..... Auto
Event ..... Auto Search
Measurement Parameter
Wave Length ..... 1.31um -----
DISTANCE ..... 5.000 Km(A)
Pulse Width ..... 100 nS(A)
Attenuation ..... Auto -----
IOR ..... 1.500000 -----
Average Limit Item .. Auto
Average Limit Value .. 5s -----
Backscatter Level ... 0.03dB -----
                    -59.97dB -----
Sampling Information(READ ONLY)
Data Points ..... Normal (25001)
Resolution ..... 0.200 m
                    ( 0.000Km - 5.000Km )
Communication Check .. ON
Connection Check .... OFF
Visible LD ..... OFF
Event Threshold
Splice Loss ..... 0.30 dB
Return Loss ..... 25.00 dB
FIBER LOSS ..... 5.00 dB
Warning Level
Wave Length ..... 1.31um -----
Splice Loss ..... OFF -----
Connection Loss ..... OFF -----
Return Loss ..... OFF -----
FIBER LOSS ..... OFF -----
Total Loss ..... OFF -----
Total Return Loss ... OFF -----

```

After the settings are completed, press **F1** (Print Execute).

Printing is started.

Press **F2** (Purge print jobs) to delete the contents of the internal print buffer.

# 3.5 Preview

After setting the Setup screens and connecting the optical fiber cable, the setting and connection can be checked by pressing **F4** (Preview). Since the preview function updates the trace waveform about every 0.1 seconds, the connection of connectors can be checked while checking the waveform. Even if the OTDR is set to Full Auto or Auto mode, markers can be used during measurement as in Manual mode.

The Setup screen is displayed.

**Setup mode (1/3)** 2000-Mar-29 15:10

System..... : **OTDR**  
 Channel..... : **None**

**Measurement mode**  
 Mode..... : **Auto**  
 Event..... : **Auto Search**

**Measurement Parameter**

Wavelength (λ)..... :	1310nm	1410nm	1550nm	1625nm
Distance Range..... :	25km			
Pulse Width..... :	1000ns			
Attenuation..... :	Auto	Auto	Auto	Auto
IOR..... :	1.465500	1.465800	1.466100	1.466500
Average Limit Item..... :	Number			
Average Limit Value..... :	33	60	60	60
Backscatter Level..... :	-50.00dB	-51.00dB	-52.50dB	-54.50dB

**Sampling Information**  
 Data Points..... : **Normal(25001)**  
 Resolution..... : **1.00m**  
 Range..... : **0.000km - 25.000km**

Buttons on the right:  
 Recall DFN  
 Save DFN  
 Setup (2/3)  
 Preview  
 Close

Legend:  
 (Item) : Item  
 (Sel) : Select  
 (Item) : Item  
 (Item) : Item

Press **F4** (Preview).

**Preview** 1999-Aug-04 18:57

Anritsu  
 CH: 1ch λ: 1310nmSM AVG: 0/5s PM/VLD/LS  
 DR: 25km IOR: 1.450000 Res: 1.00m  
 PW: 1000ns ATT: 10.000dB(A)

Buttons on the right:  
 Setup  
 Select λ  
 Select CH  
 Splice & Return Loss  
 LSA  
 10.0000 dB/div  
 2.50000 km/div  
 (Move) : Move  
 (Sel) : Select  
 Zoom Shift Marker  
 (Item) : Select  
 (Item) : Move

Trace Data:  
 DISTANCE : 11.84483 km  
 LOSS : 7.90 dB  
 FIBER LOSS : 0.67 dB/km  
 TOTAL RETURN LOSS : \*\* \*\* dB

Additional Data:  
 0.25862km  
 12.10345km

### Section 3 Setup and Setting of Peripheral Units

Setup	F1
Select $\lambda$	F2
Select CH	F3
Splice & Return Loss	F4
LSA	F5

**F1** (Setup)

Stops the measurement and displays the Setup screen again.

**F2** (Select  $\lambda$ )

Switches the measurement wavelength each time it is pressed.

The wavelength to be switched to varies the type of the OTDR main unit, as well as those specified in Setup.

Example:

MW9076C: A wavelength (1310 nm) is specified on the Setup screen;

1310 nm  $\rightarrow$  1550 nm  $\rightarrow$  1625 nm  $\rightarrow$  1310 nm

MW9076C: Two wavelengths (1310 nm and 1625 nm) are specified on the Setup screen;

1310 nm  $\rightarrow$  1625 nm  $\rightarrow$  1310 nm

**F3** (Select CH)

Switches the channels of the optical channel selector built in (connected to) the OTDR. Each time the key is pressed, the displayed channel is changed.

Example:

CH1  $\rightarrow$  CH2  $\rightarrow$  CH3  $\rightarrow$  CH4  $\rightarrow$  CH1  $\rightarrow$  CH2  $\rightarrow$  ... For the MU960001A

The number of channels depends on the optical channels selector built in (connected to) the OTDR.

**F4** (Splice & Return Loss)

Switches the contents of the measurement. The selectable item is "Splice & Return Loss" or "Loss & TORL (Total Return Loss)".

Each time the key is pressed, the displayed function key label is changed. Since Splice & Return Loss is displayed in the above figure, the currently set measurement is Loss & TORL.

**F5** (LSA)

Switches the linear approximation methods.

Each time the key is pressed, the displayed function key label is changed and the settings are changed. Since LSA (Least Square Approximation) is displayed in the above figure, the currently set measurement is 2PA (2 Pint Approximation).

See "1.6 Linear Approximation Methods LSA/2PA" and "Appendix B Least Square Linear Approximation Method" for more information on how to perform linear approximation.

## CAUTION

**The OTDR outputs high-power optical pulses. Please disconnect the communication equipments from the optical fibers before measurement in case that the optical sensor breaks.**

# Section 4 Operation (OTDR Measurement)

This section explains how to operate the OTDR with the OTDR measurement as an example.  in this section indicates a panel key.

4.1	Turning on the Power .....	4-2
4.2	Setting the Measurement Conditions .....	4-4
4.3	Starting a Measurement .....	4-9
4.4	Reading the Event Table .....	4-10
4.5	More .....	4-13
4.6	Auto Zoom .....	4-15
4.7	Editing the Events .....	4-16
4.7.1	Adding an event .....	4-17
4.7.2	Moving an event .....	4-19
4.7.3	Deleting an event .....	4-20
4.7.4	Fixing and researching an event .....	4-21
4.7.5	Entering an event comment .....	4-22
4.7.6	Input of landmark .....	4-24
4.8	Moving to the Manual Measurement Screen .....	4-26
4.8.1	How to perform an accurate measurement .....	4-28
4.8.2	Returning to the Event Table screen ..	4-29
4.9	Using the Repeat Task Function .....	4-30
4.9.1	Connecting the test fiber .....	4-30
4.9.2	Setting the measurement conditions ..	4-31
4.9.3	Fixing an event .....	4-31
4.9.4	Moving to the Repeat task mode .....	4-32
4.9.5	Setting the conditions for repeat task .	4-33
4.9.6	Reading the measurement result .....	4-37
4.9.7	Constraints .....	4-38
4.10	Relative Distance Measurement .....	4-39
4.11	Comparing Waveforms .....	4-41
4.12	Measurement Examples .....	4-47
4.12.1	Measuring the absolute distance .....	4-48
4.12.2	Measuring the relative distance .....	4-49
4.12.3	Measuring the connection loss (splice) .....	4-51
4.12.4	Measuring the connection loss (connector) .....	4-52
4.12.5	Measuring the transmission loss .....	4-54
4.12.6	Measuring the return loss .....	4-55

See “Appendix I Simple OTDR Operation Method” for more information.

## 4.1 Turning on the Power

This section explains the method of turning on the power. The explanation assumes that the battery pack has been charged or the AC adapter has been connected properly. Refer to the following sections to understand the charging method or the AC adapter connection method.

Charging method: Section 2.3.2 Charging the battery pack

Connection method: Section 2.2 Connecting the Power Supply

Turn on the power switch on the left side of the OTDR. (Press the side indicated with "|".)

If the OTDR is started normally, Setup screen 1 appears as shown below.

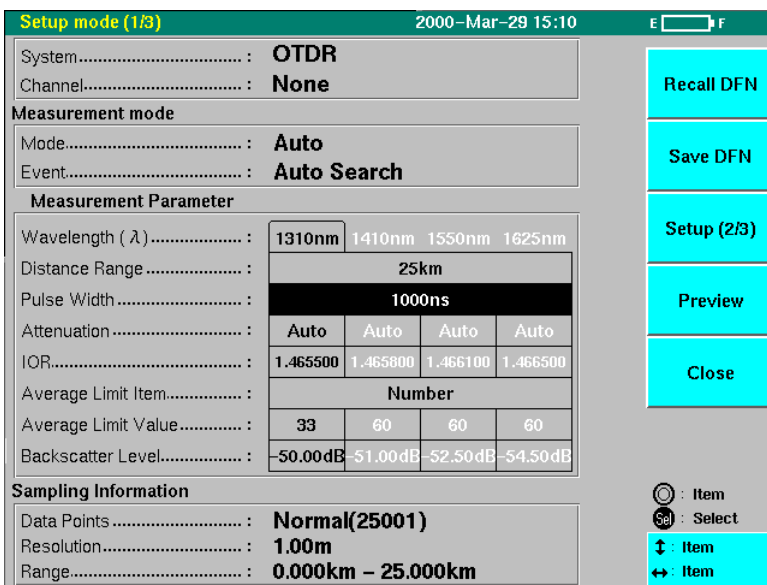

There is a possibility of OTDR failure if Setup screen 1 does not appear after the power is turned on. In this case, turn off the power and contact Anritsu Corporation or your nearest service representative.

**Note:**

It takes about 1 minutes to display the Setup screen after the equipment is switched on.



**CAUTION** 

---

If the OTDR power is turned on while the power of the printer connected to the OTDR is on, the OTDR may not start up correctly, and then the following message may be displayed.

**Non-system disk or disk error**

**In this case, turn both the OTDR and printer power off, and then turn the OTDR power on, again.**

---

**Display of Residual Capacity of the Battery Pack**

An indicator of residual capacity of the battery pack is located at the top right of the all the screens displayed. Residual capacity shown on the indicator drops in steps of 10% in the range between 100% and 10%, once below 10% it will drop to 5% and then to 3%.

Residual capacity of the battery pack between 100% and 40% is indicated in green, below 40% is indicated in yellow and below 5% is indicated in red. When residual capacity of the battery pack drops to 3%, information on setting conditions and displayed waveforms are stored into the memory on the main unit, and the unit automatically turns off. When the unit is restarted, the measurement conditions and waveforms are displayed again. Note that when the unit is turned off by the power switch, waveforms will not be stored in memory. When turning off the power for the unit using the power switch, it is possible to set whether to save the waveform or not before just as with the auto power off function.

## 4.2 Setting the Measurement Conditions

The Setup screen is displayed after the power is turned on. Set the measurement conditions on this screen. Refer to “Section 3.2 Explanation of Setup Screens” for the meaning of each item on the Setup screen.

### Setting measurements

OTDR is selected when MW9076B/B1/C/J/K is turned on. When MW9076D/D1 is turned on, the last measurement (either OTDR or CD) performed when it was turned off is selected. Possible measurement selections are listed below.



- MW9076B/B1/C: OTDR only, or OTDR and OLTS (when option 02 or 03 is mounted.)
- MW9076D/D1: OTDR and CD
- MW9076J/K: OTDR only

### Setting the Channel



No channel can be set if a built-in or external optical channel selector is not connected. Since this explanation assumes that there is no optical channel selector, the setting cannot be changed.

### Setting the Measurement mode

First set Mode to Full Auto.

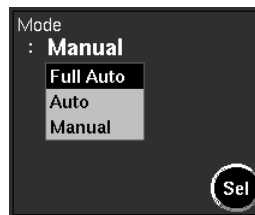
- (1) Place the cursor on Mode using the rotary knob or the  and  keys.
- (2) After the cursor is positioned on Move, press  or press the rotary knob. A window indicating options is opened.



- (3) In the window, place the cursor on Full Auto using the rotary knob or the  and  keys.
- (4) After the cursor is positioned on Full Auto, press  or press the rotary knob to enter the selected option. After the option is entered, the window is closed and the Setup screen is displayed again.

When the measurement mode is set at Full Auto, the event is automatically set to Auto Search.

**Setting the Measurement Parameters**

First, set the Wavelength.

- (1) Place the cursor on Wavelength using the rotary knob or the  $\wedge$  and  $\vee$  keys.
- (2) After the cursor is positioned on Wavelength, press **Select** or press the rotary knob. A window indicating options is opened.

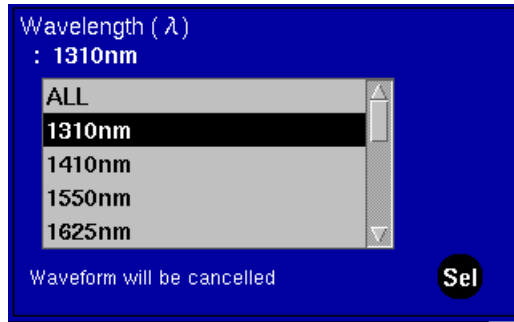

- (3) In the window, place the cursor on 1310 nm using the rotary knob or the  $\wedge$  and  $\vee$  keys.
- (4) After the cursor is positioned on 1310 nm, press **Select** or press the rotary knob to enter the selected option. The window is closed and the Setup screen is displayed again.

Since Mode is set to Full Auto for Distance, Pulse Width, and Attenuation value, Auto setting is enabled for them.

Next, set IOR.

- (1) Place the cursor on IOR using the rotary knob or the  $\wedge$  and  $\vee$  keys.
- (2) After the cursor is positioned on IOR, press **Select** or press the rotary knob. A window is opened for setting the value.

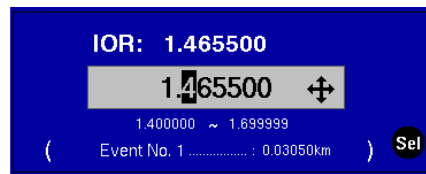

- (3) In the window, place the cursor on the desired digit using the  $\leftarrow$  and  $\rightarrow$  keys and change the number with the rotary knob or the  $\wedge$  and  $\vee$  keys.
- (4) After the value is changed, press **Select** or press the rotary knob to enter the changed value. The window is closed and the Setup screen is displayed again.

In this explanation, the IOR value 1.500000 is unchanged.

**Set sampling information**

Set data points.

- (1) Place the cursor on data points by using the rotary knob or the  $\wedge$  and  $\vee$  keys.
- (2) When you have placed the cursor, press **Select** or the rotary knob to open the window to set data points.
- (3) Move the cursor using the  $\wedge$  and  $\vee$  keys, and select one from Quick, Normal, and High.
- (4) After you move the cursor, press **Select** or the rotary knob to determine it. When you determine it, the window closes to return to the Setup screen. Keep the data points at "Quick" here.

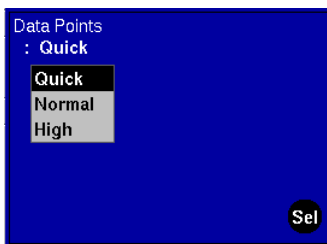

When the setting on Setup screen 1 is completed, the screen display is as shown in the following figure.

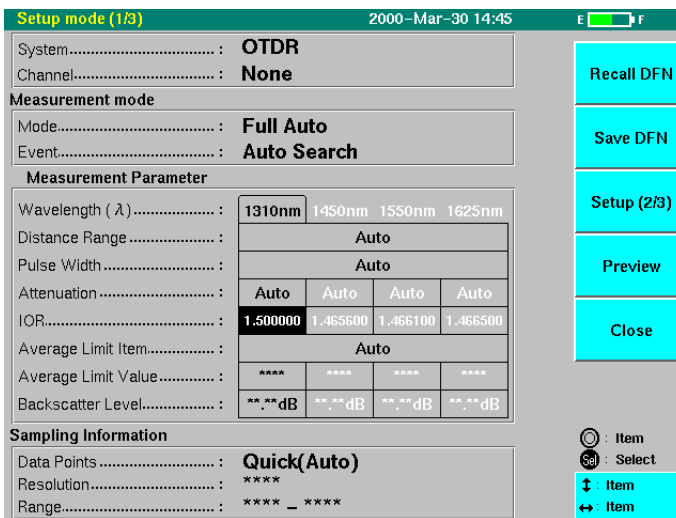

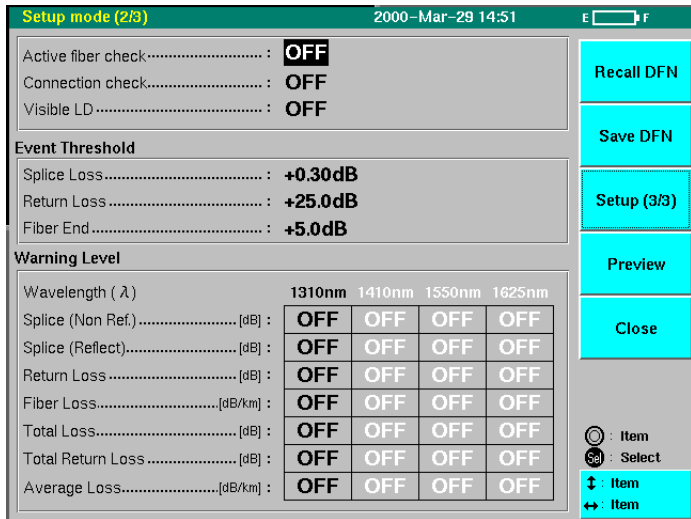

Next, set the items on Setup screen 2.

When **F3** (Setup 2/3) is pressed, Setup screen 2 appears. (See the figure below.)





### Setting the Active Fiber Check

To make measurements on the actual communication line, set it to ON in order to check for communication light. If measurements are not made on an actual communication line, set it to OFF.

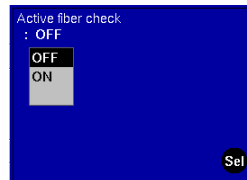
- (1) Put the cursor on Active fiber check using the rotary knob or the  and  keys.
- (2) After the cursor is positioned on Mode, press  or the rotary knob. A window indicating options is opened.



- (3) In the window, place the cursor on ON or OFF using the rotary knob or the  and  keys.
- (4) After the cursor is positioned on ON or OFF, press  or press the rotary knob to enter the selected option. The window is closed and the Setup screen is displayed again.

In this example, OFF is set.

### Setting the Connection Check

To check the connection between the optical connector in the OTDR main unit and the connector of the optical fiber connected to it, set it to ON. The connection is checked at every measurements. The first check is performed immediately after the optical fiber is connected. If no problems are found in the first check, it is better to set this setting to off for the faster measurement.

Refer to the above paragraph “Setting the Active fiber check” for the settings.

**Setting the Event Threshold**

Set the level for detecting events. The OTDR detects and displays the events based on the value set here.

First, set the threshold level of Splice Loss.

- (1) Place the cursor on Splice Loss using the rotary knob or the  $\wedge$  and  $\vee$  keys.
- (2) After the cursor is positioned on Splice Loss, press **Select** or press the rotary knob. A window for setting a value is opened.

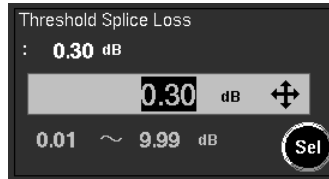

- (3) In the window, place the cursor on the desired digit using the  $\lt$  and  $\gt$  keys and change the numeric value using the rotary knob or the  $\wedge$  and  $\vee$  keys.
- (4) After the value is changed, press **Select** or press the rotary knob to enter the changed value. The window is closed and the Setup screen is displayed again.

In this example, Threshold Splice Loss is set to 0.3 dB.

In the same way, set Return Loss and Fiber End of Event Threshold. In this example, Return Loss is set to +40.0 dB and Fiber End is set to +1 dB.

When the settings on Setup screen 2 are completed, the screen display is as shown in the following figure.

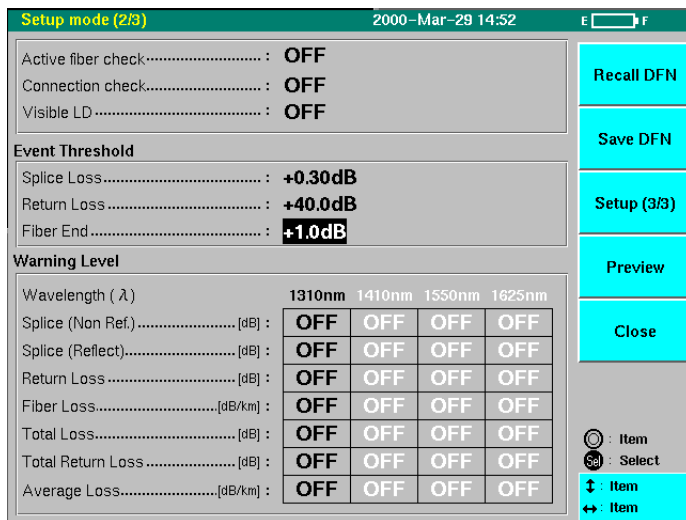

## 4.3 Starting a Measurement

Start a measurement in Full Auto set in “Section 4.2 Setting the Measurement Conditions.” This explanation assumes that setting in Full Auto measurement has already been completed.

First, connect the optical fiber to be tested.

Refer to “Section 2.7 Connecting the Optical Fiber Cable” for the connection method.

After the optical fiber is connected, press **Start**.

When **Start** is pressed, the OTDR performs the following operation and displays the event table screen. (in Full Auto measurement)

**(1) Performs automatic setting**

Detects the optimum values of the distance range, pulse width, attenuation, and averaging.

**(2) Processes the waveform and searches for faults**

Performs the smoothing of the waveform and detects the faults.

Calculates the information on each fault.

### CAUTION

---

**The OTDR outputs high-power optical pulses. Please disconnect the communication equipments from the optical fibers before measurement in case that the optical sensor breaks.**

---

## 4.4 Reading the Event Table

After the fault search is completed in Full Auto measurement, the following measurement waveform and event table are displayed.

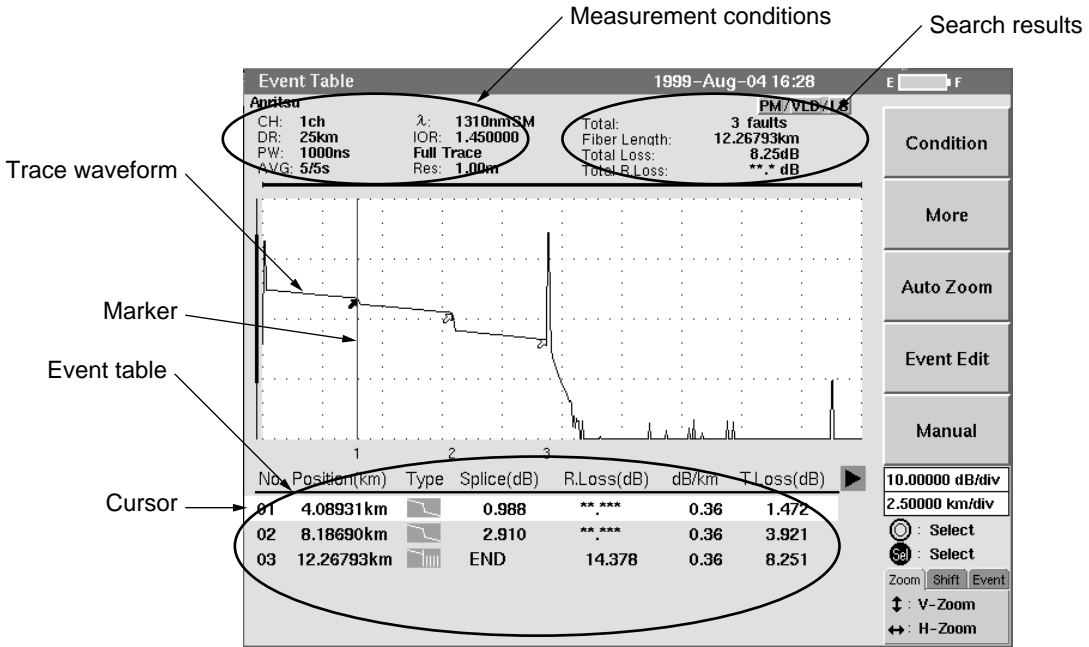

The following items are displayed on the event table screen in the above figure.

### Measurement conditions

CH: Optical channel selector                                      λ: Wavelength of measured light  
 DR: Distance Range    IOR: Index of refraction  
 PW: Pulse width    ATT: Attenuation  
 AVG: The states of averaging    Res: Resolution

### Note:

The displayed values of the items set to Auto are chosen by the OTDR.

### Search results

Total: Total number of faults                                      Fiber Length: Length of fiber  
 Total Loss: Total loss of fiber  
 Total Return Loss or Average Loss: Total return loss from the connecting point between the OTDR and the fiber to the sampling end point, or total loss/fiber length

### Note:

“\*\*\*.\*\*\*km” is displayed for Fiber Length when the far end of the fiber cannot be detected.



**Trace waveform**

The waveform is displayed with the attenuation on the vertical scale and the distance on the horizontal scale. The scale of each axis is displayed at the bottom right of the screen. The ◁ symbol is displayed at each fault point.

**Event table**

The following values are displayed for each event.

- No: Fault number counted from the left of the screen
- Position: Distance of the event from the OTDR
- Type: The types of the event      Splice: Connection loss
- R.Loss: Return loss                      dB/km: Fiber loss
- T.Loss: Total loss up to the point

**Note:**

If either the splice loss or return loss exceeds the event threshold value set on Setup screen 2, the point is determined as a fault. A value below the threshold value is enclosed by parentheses. If the measurement value cannot be obtained for some reason such as the proximity of faults, \*.\*.\* is displayed.

Automatic measurement is a supporting function which enables to operate easier, it doesn't assure results. As there is a case of miss detection, check the waveform as well.

After the ▷ key is pressed when the event table is displayed as shown below and the card is set to Event, the succeeding items can be seen.

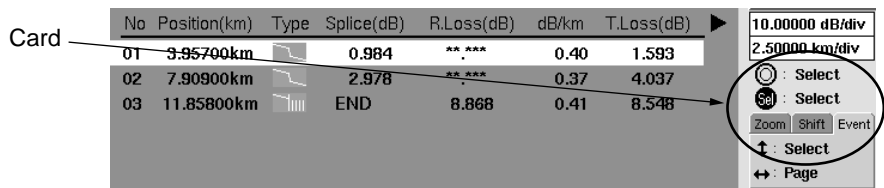

Press ▷

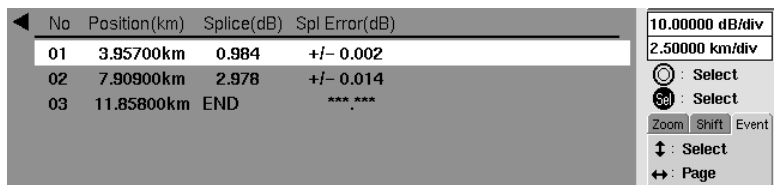

- No: Fault number counted from the left of the screen
- Position: Distance of the event from the OTDR
- Splice: Splice loss                      Spl Error: Splice-loss error







Then press ▷ to scroll the page forward. Indications can move fast in the table when multiple events exist.

**Event selection change**







When the full automatic measurement is completed, No.1 of event table is selected where the cursor is placed. This cursor can be moved to change the selection of the event on actual trace waveform to read each event information, to zoom in the view, to edit the event, etc. The  $\wedge$  and  $\vee$  keys or the rotary knob are used to change the event selection. However, the cursor movements vary.

$\wedge$  and  $\vee$  keys: Move the cursor up and down in the events order in the table. When the measurement of multiple wavelength is displayed in Disp. All Traces as described later (see 4.5 More), events are listed in the order starting from the near end regardless of the trace waveform (wavelength). When using the  $\wedge$  and  $\vee$  keys to move the cursor, the cursor moves to the next event regardless of the wavelength and the marker display is moved to the trace waveform of the wavelength corresponding to the selected event.







**Rotary knob:** The cursor moves between events of an identical wavelength only.

No	Position(km)	Type	Splice(dB)	R.Loss(dB)	dB/km	nm
01	0.50350km		0.010	** ** ** *	3.319	850
01	0.50350km		( 0.002)	** ** ** *	0.520	1300
02	1.00450km		0.068	** ** ** *	3.184	850
02	1.00150km		0.064	** ** ** *	0.500	1300
03	1.21750km		END	( 54.844)	3.164	850
03	1.21200km		END	( 50.094)	0.504	1300

Before moving the cursor

No	Position(km)	Type	Splice(dB)	R.Loss(dB)	dB/km	nm
01	0.50350km		0.010	** ** ** *	3.319	850
01	0.50350km		( 0.002)	** ** ** *	0.520	1300
02	1.00450km		0.068	** ** ** *	3.184	850
02	1.00150km		0.064	** ** ** *	0.500	1300
03	1.21750km		END	( 54.844)	3.164	850
03	1.21200km		END	( 50.094)	0.504	1300

After moving the cursor with the  $\vee$  key

No	Position(km)	Type	Splice(dB)	R.Loss(dB)	dB/km	nm
01	0.50350km		0.010	** ** ** *	3.319	850
01	0.50350km		( 0.002)	** ** ** *	0.520	1300
02	1.00450km		0.068	** ** ** *	3.184	850
02	1.00150km		0.064	** ** ** *	0.500	1300
03	1.21750km		END	( 54.844)	3.164	850
03	1.21200km		END	( 50.094)	0.504	1300

After moving the cursor with the rotary knob

# 4.5 More

The following screen is displayed by pressing **F2** (More) on the event table or the manual measurement result screen.

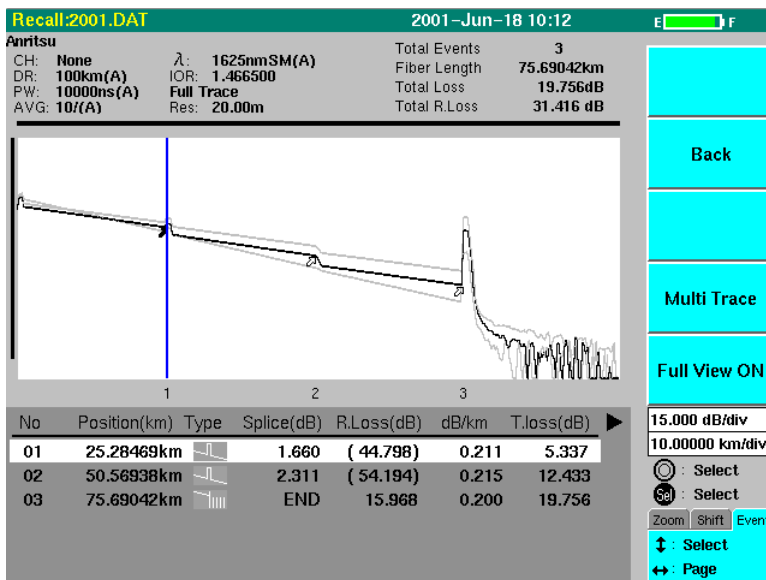

## Multi Trace

When the measurement is performed using multiple wavelengths or all wavelengths, the event table and trace waveform of only one kind of wavelength are selected first out of multiple trace waveforms. Press **F4** (Multi Trace) to change the selected display waveform, to display trace waveforms of all wavelengths, and to shift each waveform into the vertical axis direction for the comparison. By pressing **F4** (Multi Trace), the following screen is displayed:

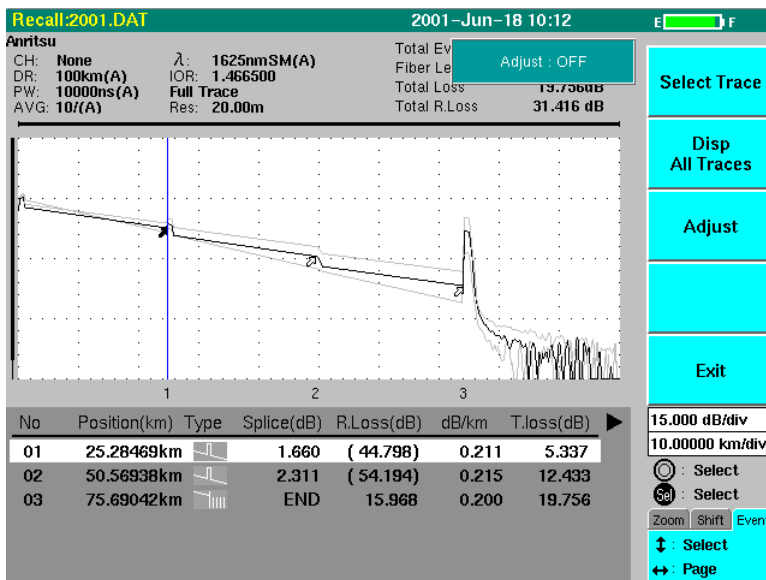

**Select Trace (F1)**

Press **F1** (Select Trace) to select event tables and trace waveforms of different wavelengths. Every time the button is pressed, the selected waveform is switched and the event table is also changed corresponding to the wavelength.

**Disp All Traces (F2)**

By pressing **F2** (Disp. All Traces), event tables and trace waveforms of all measured wavelength are displayed. Events are listed in order starting from the near end regardless of the wavelength.

When you want to display only one trace waveform and event table again, press **F2** (Disp. Selected Trace).

**Adjust (F3)**

It is used to compare waveforms measured in multiple wavelengths.

Whenever the **F3** (Adjust) button is pressed, the overlap, each waveform shifted and displayed on the vertical axis in the 0.5 division interval, the waveform shifted and displayed on the vertical axis in the 1 division interval, and the adjustment OFF are switched in this description order. The reference position of the shift is the marker position of the selected waveform.

**Full View ON**

By pressing **F5** (Full View ON), the entire waveform of the waveform currently viewed is displayed at the upper right of the screen. When a part of the waveform is zoomed in, it is indicated by the frame currently displayed on the full view screen. When you want to erase the full view screen, press **F5** (Full View OFF) again.

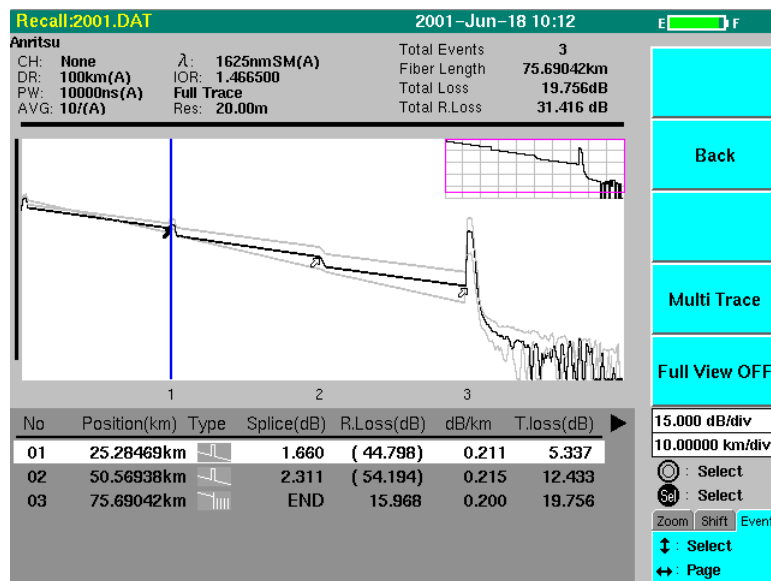

## 4.6 Auto Zoom

Press **F3** (Auto Zoom) on the Event Table to enlarge the section which is indicated by the marker and display information concerning this event at the bottom. Press **^**, **v**, **<** or **>** to move to the enlarged view of the previous or following event when the Card is set at Event. See “4.7 Editing Events” for more information on how to edit events.

Press **F3** (Event Table) to cancel Auto Zoom.

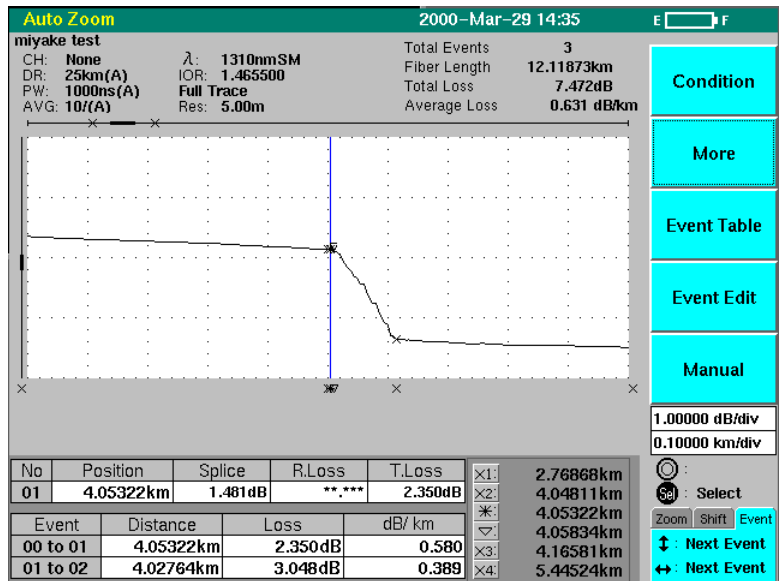

## 4.7 Editing the Events

Edit the events to save the data of splices that are not included in the event table or to delete points that are evaluated as faults because of noise.

When **F4** (Event Edit) is pressed on the Event Table screen, the following Event Edit screen is displayed.

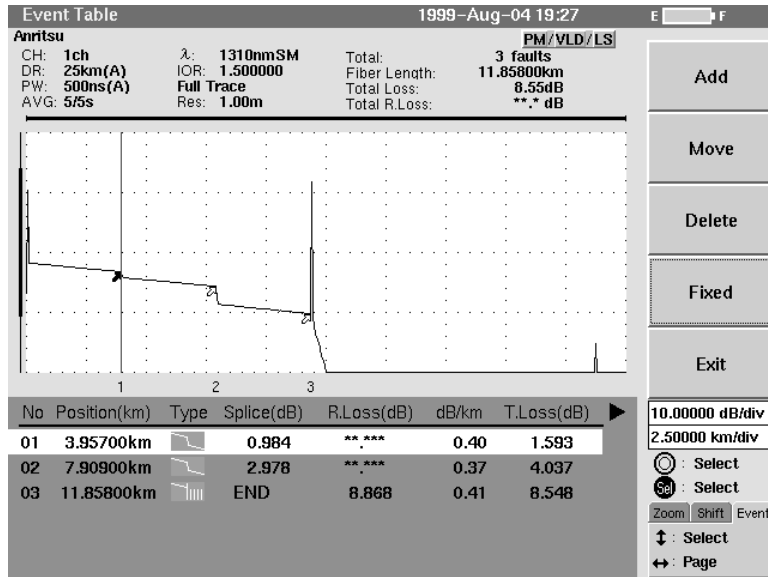

Events can be edited as shown below.

- (1) Adding an event **F1**
- (2) Moving an event **F2**
- (3) Deleting an event **F3**
- (4) Registering and researching an event **F4**
- (5) Entering an event comment **F5**

### 4.7.1 Adding an event

When **F1** (Add) is pressed on the Event Edit screen, the \* and ∇ markers are displayed along with two × markers on each side of these markers as shown below.

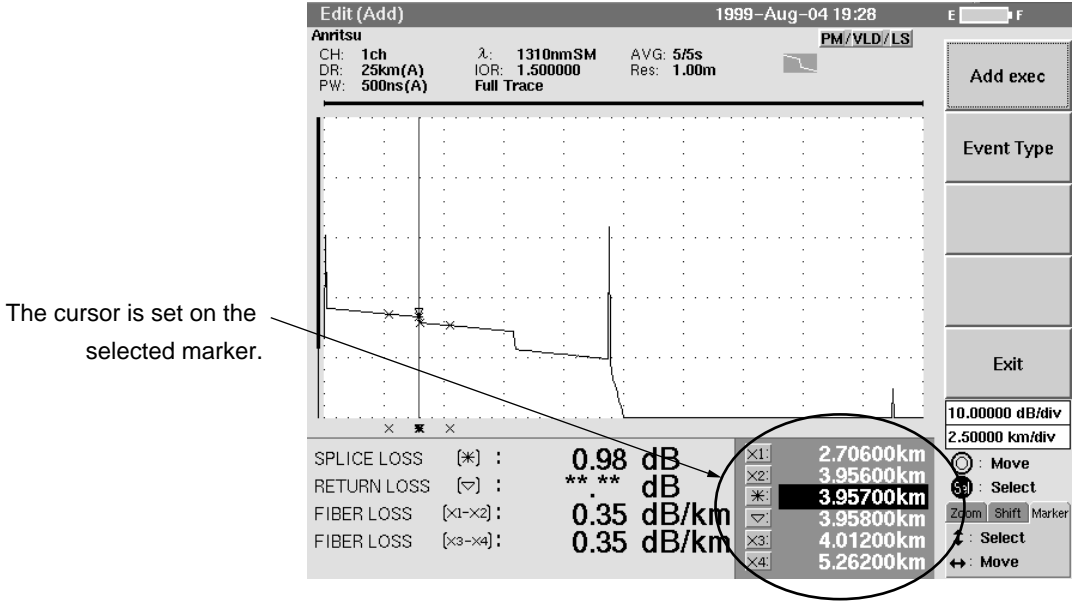

Select the \* marker with the **∧** and **∇** keys.  
 Move the \* marker to the desired position with the **<** and **>** keys.  
 After moving the \* marker to the position at which an event is to be added, press **F2** (Event Type) to select the event type.  
 When the event type cannot be determined, select "Reflect."

NonRef.	<b>F1</b>
Reflect	<b>F2</b>
Fiber End	<b>F3</b>
Group Event	<b>F4</b>
Exit	<b>F5</b>

- Non Ref:** Set when the event is non-reflection such as a fusing point.
- Reflect:** Set when the event is reflection such as a splice point (Fresnel reflection).
- Fiber End:** Set when the event is the far end of the fiber under test.
- Group Event:** Set when it is considered as one event if the multiple events cannot be identified because they are so close.
- Exit:** Returns to the Edit (Add) screen without changing the event types.

## Section 4 Operation (OTDR Measurement)

After the event type is selected, the Event Edit screen is displayed again.

When **F1** (Add exec) is pressed, the Even Table screen is displayed again, and the event is added.

An asterisk (\*) is appended before the added event so that the added event is recognized.

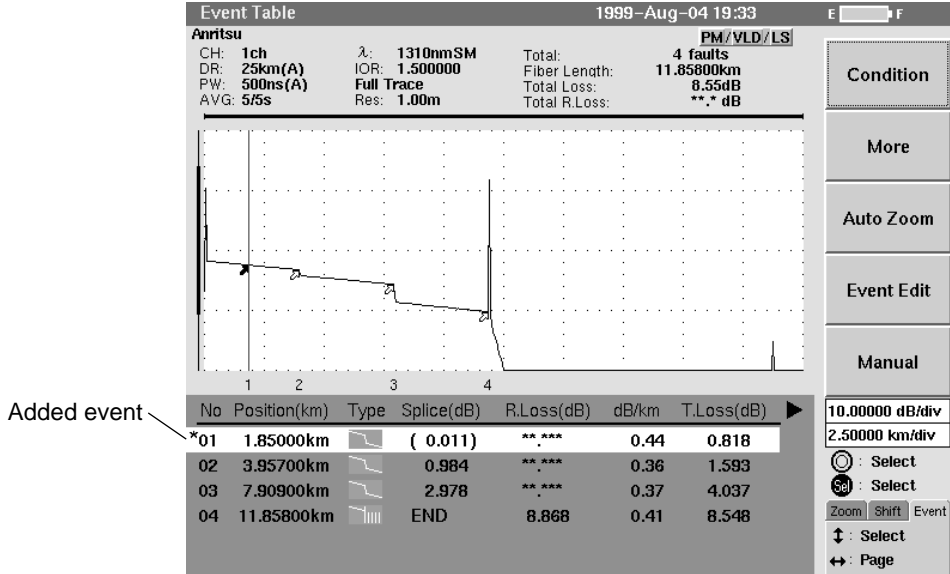



## 4.7.2 Moving an event

Select the event to be moved by pressing the  $\wedge$  and  $\vee$  keys with the event card in the Event Edit screen selected.

After the event is selected, press  $F2$  (Move).

As shown in the following figure, the zoomed waveform with the selected event at the center of the screen is displayed.

On this screen, six markers are displayed as in the Edit (Add) screen.

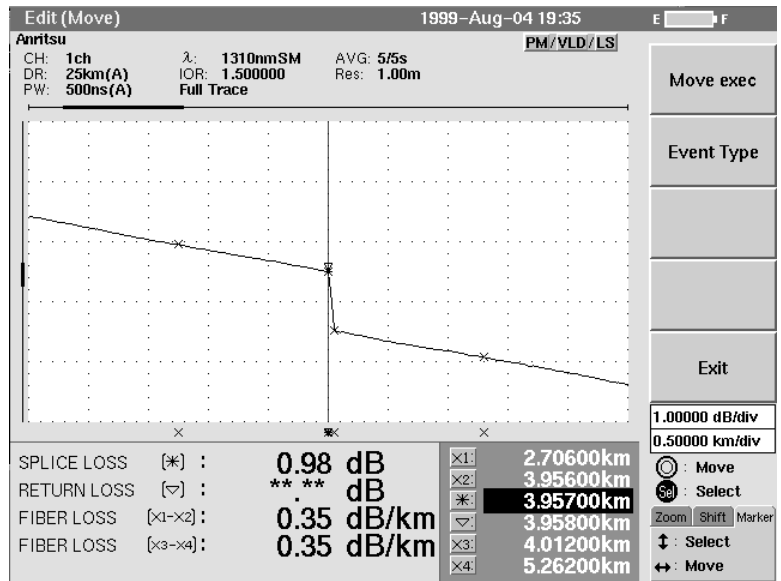

Select the \* marker with the  $\wedge$  and  $\vee$  keys.

Move the \* marker with the  $\leftarrow$  and  $\rightarrow$  keys.

After moving the \* marker to the desired position, press  $F1$  (Move exec).

The movement of the event is entered and the Event Table screen is displayed again.

An asterisk (\*) is appended before the moved event on the Event Table screen.

To change the event type of the event to be moved, press  $F2$  (Event Type) to change the event type before pressing  $F1$  (Move exec).

### 4.7.3 Deleting an event

Select the event to be deleted by pressing the  $\wedge$  and  $\vee$  keys with the event card in the Event Edit screen selected.

After the event is selected, press **F3** (Delete).

As shown in the following figure, the zoomed waveform within the neighborhood of the selected event is displayed for confirmation.

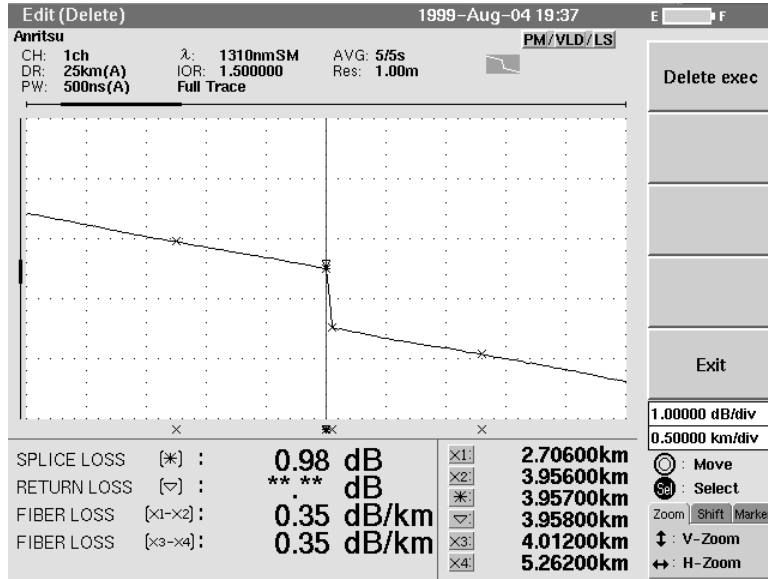

If there is no error in the event to be deleted, press **F1** (Delete exec).

The event is deleted and the Event Table screen is displayed again.

It is not possible to restore the event after it is deleted by pressing **F1**.

#### 4.7.4 Fixing and researching an event

When the event edit screen is displayed, "Fixed" or "ReAutoSearch" is displayed on the **F4** function key label. When "Fixed" is displayed on the key label, this instrument is set to "ReAutoSearch". When you press **F4** (Fixed), the setting is changed to "Fixed" and the **F4** label changes to "ReAutoSearch". Conversely, when "ReAutoSearch" is displayed on the key label, this instrument is set to "Fixed".

When you press **F4** (ReAutoSearch), the setting is changed to "ReAutoSearch" and the **F4** label changes to "Fixed".

##### **Fixed**

If Fixed is selected while the event table is displayed, all the events displayed at this point of time are stored in the OTDR internal memory. (The user cannot access the data.)

If a measurement is started again in this state, the vicinity of the event table stored in Auto Search is searched.

This function is effective when measurement is always made on the fixed point.

##### **Re Auto Search (Researching an event)**

If Re Auto Search is selected when an event table is created, event search is performed again on the waveform displayed at this point of time.

If Re Auto Search is executed, the event information in the OTDR internal memory stored by Fixed is erased.

### 4.7.5 Entering an event comment

A comment can be entered for each event displayed in the event table. The following screen is displayed when **Menu** is pressed on the Event Table screen.

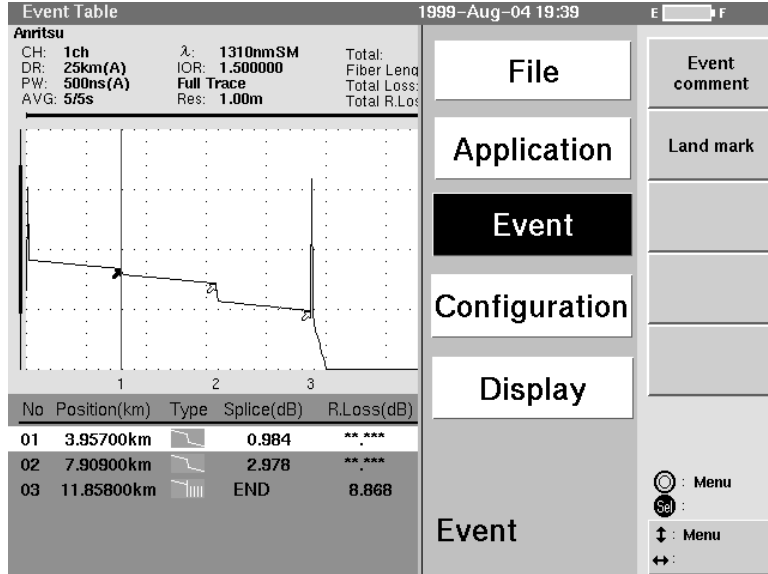

Select Event by pressing the **^** and **v** keys. The following screen is displayed when **F1** (Event comment) is pressed.

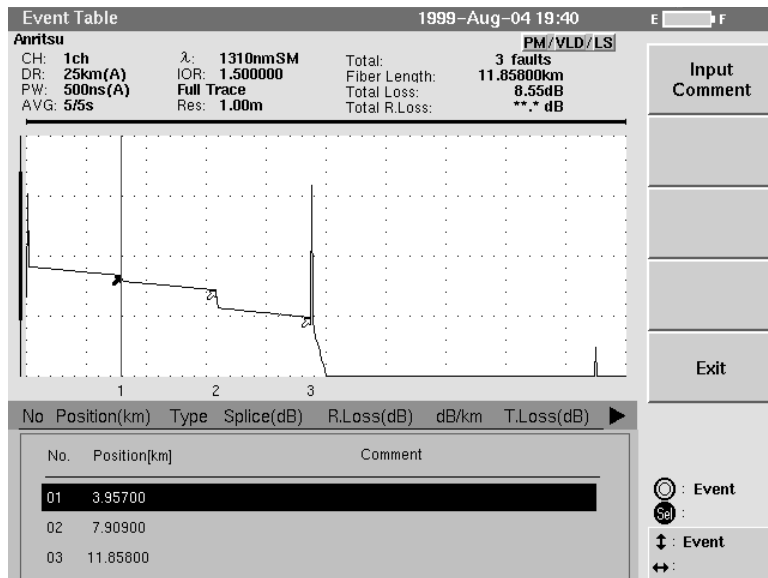

Select an event by rotating the rotary knob or by pressing the  $\wedge$  and  $\vee$  keys.

The page can be changed with the  $\leftarrow$  and  $\rightarrow$  keys. Three events are displayed on one page.

Press **F1** (Input Comment) after an event for which a comment is to be entered is selected. A window is opened for entering the comment.

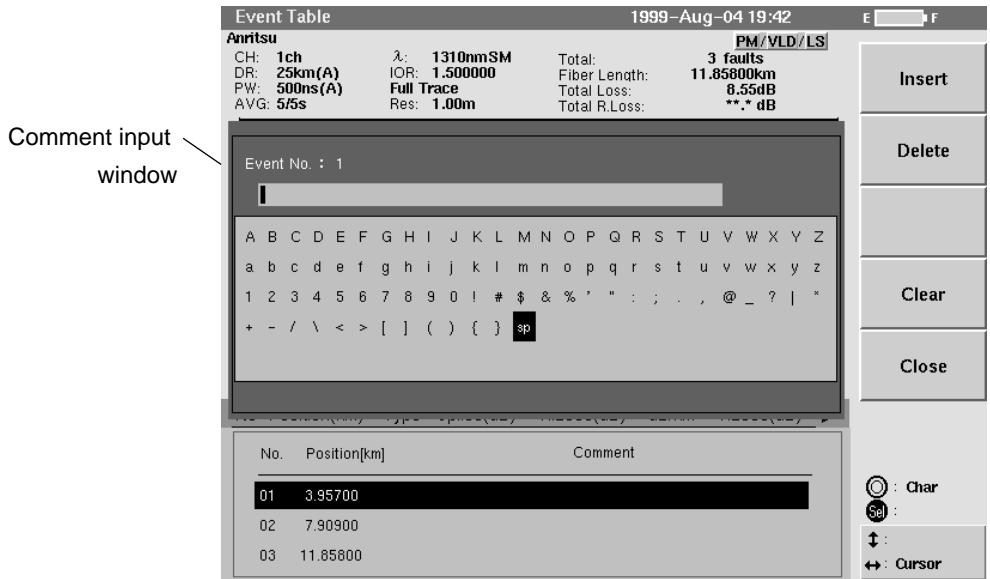

Enter a comment by selecting the characters with the rotary knob and by moving the cursor with the  $\leftarrow$  and  $\rightarrow$  keys.

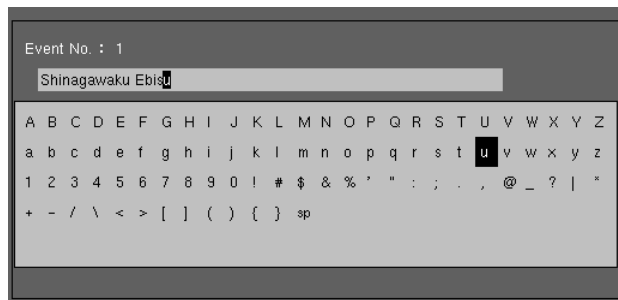

After the entry is completed, press **F5** (Close). The selected string is entered and set as a comment.

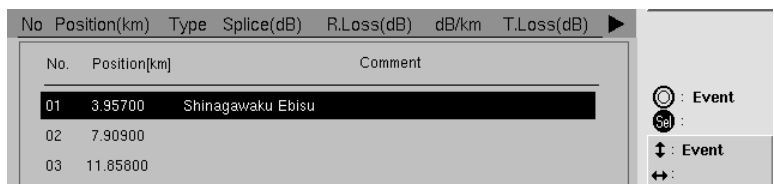

### 4.7.6 Input of landmark

The landmark can be inputted for each event displayed in the event table.

The following screen is displayed when **Menu** is clicked on the event table screen.

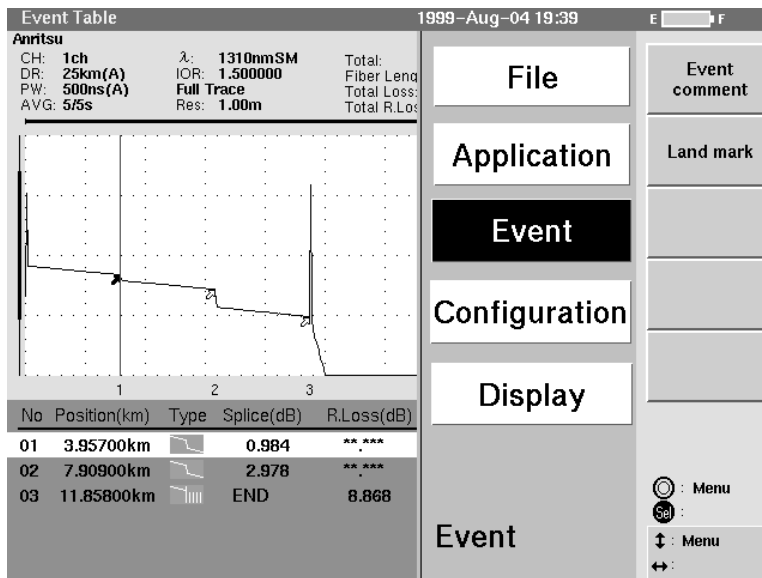

Select the event to be moved by pressing the **^** and **v** keys

The following screen is displayed when **F2** (Landmark) is clicked.

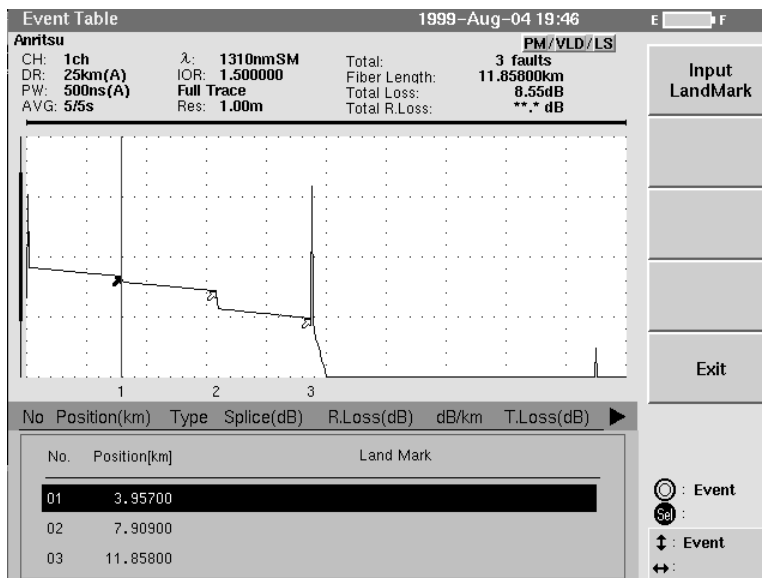

Select the event using the rotary knob or the arrow  $\uparrow$   $\downarrow$  keys. The pages can be changed using the arrow  $\leftarrow$   $\rightarrow$  keys. Three events are displayed on one page.

After the selection of an event for which a landmark is to be inputted, click the F4 (Input Landmark) key. The Landmark selection window is opened.

Landmark selection window

The screenshot shows the 'Event Table' interface for Anritsu, dated 1999-Aug-04 19:47. It displays various parameters like CH: 1ch, DR: 25km(A), PW: 500ns(A), AVG: 5/5s, and fiber-related metrics. A 'Landmark selection window' is open, listing options: BR : Bridge, CO : Central Office, CP : Coupler, FF : Fiber Distribution Frame, HT : Host Digital Terminal, HE : Head End, and HH : Handhole. Below this, a table shows the following data:

No.	Position[km]	Land Mark
01	3.95700	
02	7.90900	
03	11.85800	

Select the Landmark using the rotary knob or the arrow  $\uparrow$   $\downarrow$  keys, and execute it using the **Select** key.

The screenshot shows the 'Event Table' interface with the 'Landmark selection window' now closed. The table below has been updated to include the selected landmark:

No.	Position[km]	Type	Splice(dB)	R.Loss(dB)	dB/km	T.Loss(dB)
01	3.95700	BR (Bridge)				
02	7.90900					
03	11.85800					

## 4.8 Moving to the Manual Measurement Screen

When **F5** (Manual) is pressed on the Event Table screen, the manual screen can be displayed by using the data collected in Auto mode and various measurements can be made by using the markers as in the manual measurement.

To return to the Event Table screen, press **F5** (Event Table) on the Manual Measurement screen.

The Manual Measurement screen is shown in the following.

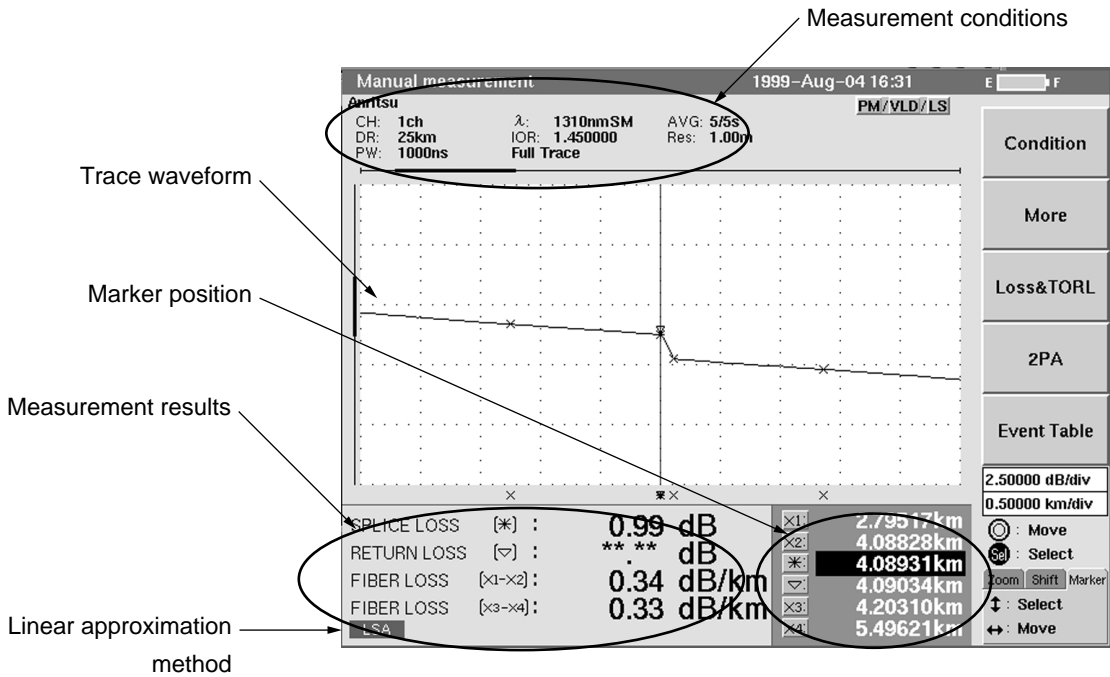

Six markers and the measurement results of splice loss and return loss are displayed on this screen. In addition, the following items are displayed.

### Measurement conditions

- CH: Channel of optical channel selector    λ: Wavelength of measured light
- AVG: The states of averaging                      DR: Distance Range
- IOR: Index of refraction                              Res: Sampling resolution
- PW: Pulse width    ATT: Attenuation

### Note:

For the items set to Auto, the values chosen by the OTDR are displayed.

### Trace waveform

The trace waveform is displayed with the attenuation on the vertical scale and the distance on the horizontal scale.



**Measurement results**

In the case of [Splice & Return Loss]

SPLICE LOSS (\*): Splice loss at point \*

RETURN LOSS (∇): Return loss at point ∇

FIBER LOSS (X1-X2): Loss between points X1 and X2

FIBER LOSS (X3-X4): Loss between points X3 and X4

In the case of [Loss & TORL]

DISTANCE: Distance between × and \* markers

LOSS: Loss between × and \* markers

FIBER LOSS: Fiber Loss between × and \* markers

TOTAL RETURN LOSS: Total Return Loss between × and \* markers

**Note:**

\*\*.\* is displayed if the measurement cannot be performed because of incorrect marker position. If the reflected light intensity exceeds the measurement range of the circuit, the < symbol is appended in front of the measured value.

**Marker positions**

The distance from the optical connector of the OTDR to each marker.

**Linear approximation method**

LSA (Least Square Approximation) or 2PA (2-point Approximation) is displayed.

**Contents of function keys****F1 (Condition)**

Select this key to set the measurement conditions again. This key can call up the Setup screen and the preview screen.

**F2 (More)**

Displays the next page of the function key label.

At **F5**, Full View ON or Full View OFF is displayed. When **F5** is pressed in the ON state, the total waveform of the measurement result is displayed at the upper right of the trace waveform display. When **F5** is pressed when OFF is displayed, the total waveform display is erased.

At **F2**, Back is displayed. Pressing this key returns the display to the previous page (See the figure on the left.)

**F3 (Loss & TORL)**

Select this key to change the measurement results to loss measurement and total return loss. When this key is selected once, the function key label is changed to Splice & Return Loss. When this key is selected in this state, the measurement results are switched to splice loss and return loss and the function label is returned to the original one.

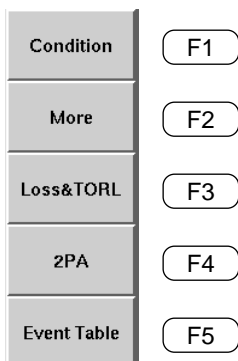

**F4 (2PA)**

Select the linear approximation method. When 2PA is displayed at the function key label, the least square approximation is selected. When this key is selected in this state, the display is changed to LSA and the 2-point approximation is selected.

**F5 (Event Table)**

Displays the Event Table screen again.

### 4.8.1 How to perform an accurate measurement

**(1) Set the marker correctly**

It is necessary to set the markers properly to obtain accurate measurement results. The good and bad examples of marker settings are shown below.

To measure the splice loss and distance correctly, it is necessary to set the \* marker or x marker for specifying the splice point at the beginning of the step on the trace waveform as shown below.

**Good**

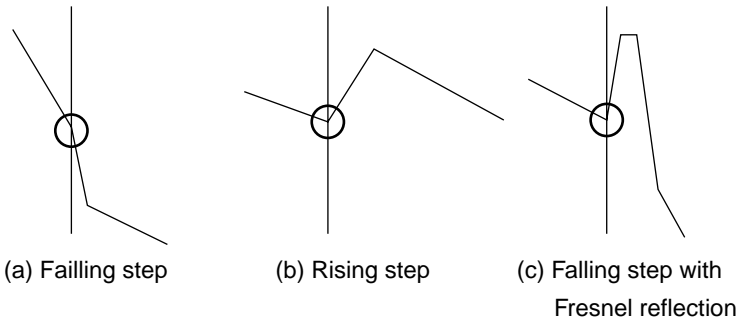

**Bad**

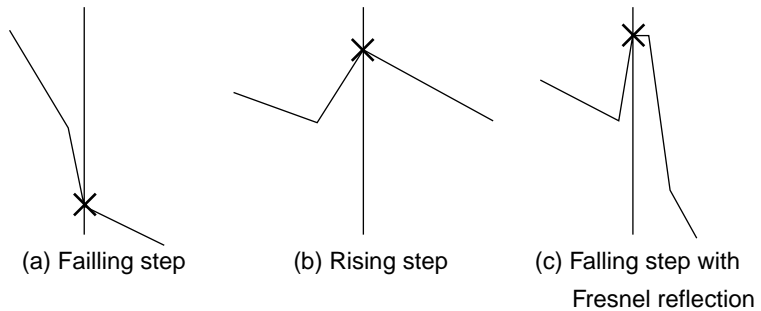

**(2) Averaging**

Read the measured values after obtaining a sufficiently smooth waveform trace using averaging. If you are not sure how long or how many times averaging should be performed, set a slightly larger value and press the **F5 (Stop)** key when a smooth waveform is displayed on the screen during averaging.

**(3) Selecting LSA or 2PA linear approximation**

Basically, use LSA to determine splice losses and 2PA to determine the total loss.

### 4.8.2 Returning to the Event Table screen

When **F5** (Event Table) is pressed on the Manual Measurement screen, the event table can be displayed by using the data collected using the Manual Measurement screen and faults can be displayed by using event markers as in the result of Auto Measurement.

## 4.9 Using the Repeat Task Function

The Repeat Task function is used to execute a series of operations from executing the measurement and recording the measurement results to printing the measurement screen while switching the optical channel selector and measurement wavelength. The execution result can also be checked in the Measurement Log table. By using this function, all connector points in a multi-core cable can be automatically evaluated.

The measurement procedure for a multi-core fiber cable is shown below.

### 4.9.1 Connecting the test fiber

This explanation is based on the assumption that a built-in or external optical selector is connected.

For the connection of an optical channel selector, refer to “Section 2.8.3 Connecting an optical channel selector.”

For the setting of an optical channel selector, refer to “Section 3.3.4 Connecting an optical channel selector.”

Connect the test fiber to the input connector of the optical channel selector. The number of connectable fibers is determined by the optical channel selector.

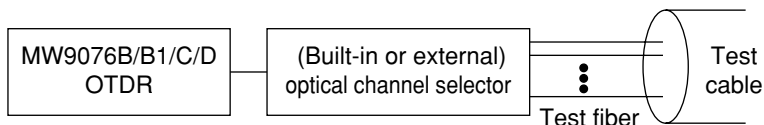

### CAUTION

**The OTDR outputs high-power optical pulses. Please disconnect the communication equipments from the optical fibers before measurement in case that the optical sensor breaks.**

## 4.9.2 Setting the measurement conditions

Set the measurement conditions and events for continuous measurement.

First, set the optimum measurement conditions.

If the optimum measurement conditions are known, set them on the Setup screen. After the settings are completed, perform a trial measurement to confirm that these conditions are optimum.

If the optimum measurement conditions are not known, use of the Full Auto function is recommended. Settings can be easily made because the Full Auto function makes measurements for the optimum measurement conditions and detects events with the preset threshold value.

For some measurement conditions, the events to be detected may not be detected. Therefore, it is necessary to check the events by making a measurement.

If the event position is different from the desired one, set the event at the proper position by using the Event Edit function.

Refer to “Section 4.7 Editing the Events” for the Event Edit function.

## 4.9.3 Fixing an event

Register an event for performing repeated measurements at the event point set in the previous section.

Refer to “Section 4.7.4 Fixing and researching events” for the details of event Fixed.

This section explains only the method of registration on the assumption that the event is set at the proper position.

An event can be fixed from the Event Edit screen, the Setup screen and the Continuous Measurement Setting screen.

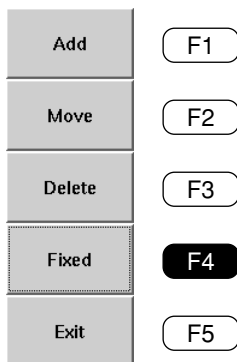

### From the Event Edit screen

The function key labels shown on the left are displayed on the Event Edit screen. The event is registered when **F4** (Fixed) is pressed in this state.

See “3.2.1 Setup screen 1” from the Setup Screens.

See “4.9.5 Setting the continuous measurement conditions” from the Continuous Measurement Setup Screen.

### 4.9.4 Moving to the Repeat task mode

Repeat task is executed based on the currently set conditions. The procedures to move to the repeat task mode are as follows:

Press **Menu** on the measurement completion screen to open the menu window. Select Application by using the **^** and **v** keys. When you select Application, "Repeat task" and "Log Table" are displayed on **F1** and **F3** of the function key labels, respectively.

#### Repeat task

By pressing **F1** (Repeat task), the following Repeat task screen is displayed:

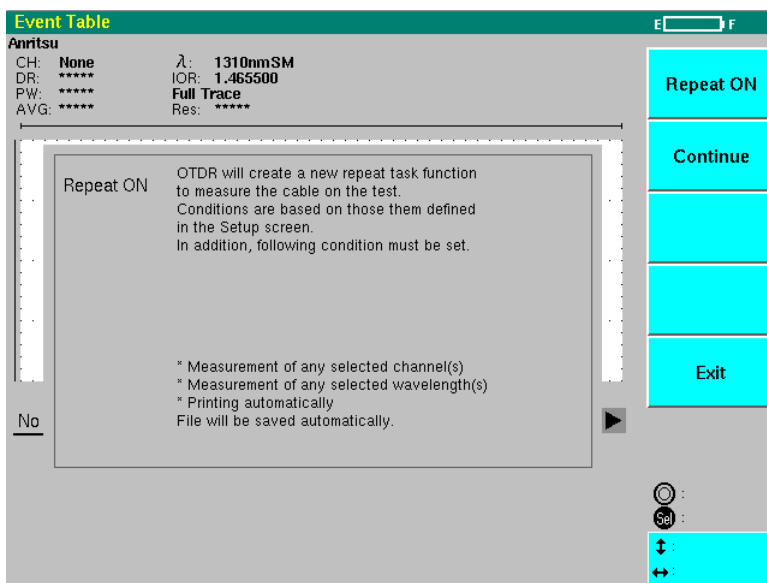

Press **F1** (Repeat ON) here to delete the previously recorded log table and to create a new log table. Afterward, move to the measurement condition setting screen of repeat task as described later.

Press **F2** (Continue) to display the previously recorded measurement log table. Then press **Start** to start measurement with the same condition as previously done. The conditions for repeat task cannot be set. Continue cannot be selected when no measurement log table is previously recorded and available.

#### Log Table

When a repeat task was previously executed and the measurement is performed again without changing the measurement condition, press **F3** (Log Table) to display the measurement log table. By pressing **Start**, the measurement is started with the previous setting and the result is added to the measurement log table. This function key has functions equivalent to those that can be selected using the aforementioned **F2** (Continue).

## 4.9.5 Setting the conditions for repeat task

Select **F1** (Repeat task) in the Application menu and press **F1** (Repeat ON) to display the following screen (example MW9076D):

Set the conditions of the Repeat task function on this screen.

### Repeat Channel

Set the measuring channel when the optical channel selector is connected. MW9076 measures set channels by switching from one to the next. Channel setting procedures are described below.

On the setting screen for sequential measurement conditions, when the cursor is in the “Repeat Channel” item press **Select** or the rotary knob to display the dialog box, as shown on the next page. Using **▲**, **▼**, **◀**, **▶** or the rotary knob move the cursor to the desired channel and then press **Select** to set it as the measurement channel.

To cancel set channel, move the cursor onto it and press **Select**.

To set multiple channels at the same time, press **F1** (Row Sel/Unsel). Channels on the same line as the cursor are selected. (For example, pressing **F1** (Row Sel/Unsel) when the cursor is on Ch 2, sets Ch 1 to Ch 4 at the same time.)

To cancel a setting, press **F1** (Row Sel/Unsel) again.

To set all the channels at the same time, press **F2** (All Sel/Unsel). To cancel this setting, press **F2** (All Sel/Unsel) again.

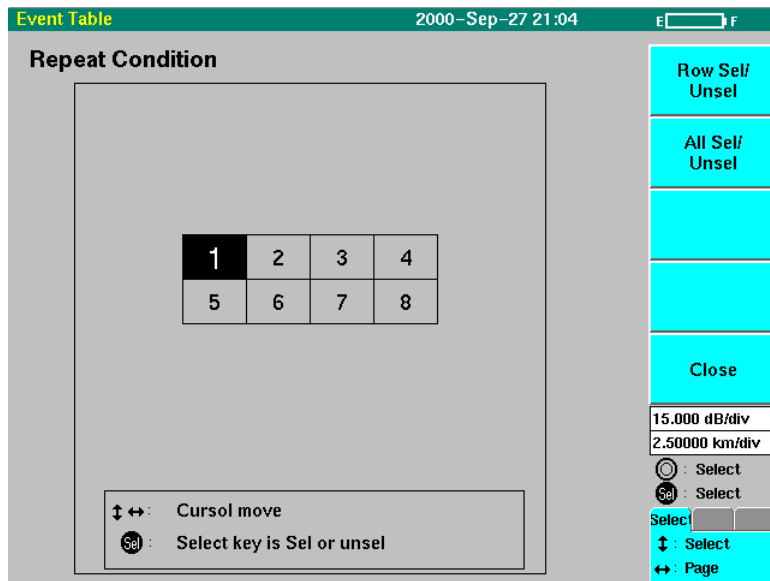

Pressing **F5** (Close) after completing channel setting confirms the channel settings and returns to the continuous measurement condition setting screen.

- \* When **F5** (Close) is pressed with no channel set, “None” is displayed for the “Repeat Channel” item. In this case, measurement is performed with the lastly set channel.
- \* When the optical channel selector is not connected, “None” is displayed for the “Repeat Channel” item and the item cannot be changed.

### Repeat Wavelength

Set a wavelength to be measured continuously. Press **Select** or the rotary knob while the cursor is located on a wavelength on the Repeat Condition Screen to display a dialog box as shown in the figure below. Position the cursor on a wavelength to be changed by using **^** or **v** or the rotary knob, then press **Select** to display the Wavelength Selection dialog box. On this dialog box, select On or Off. In order to establish the wavelength selected, press **F5** (Close) to bring the screen back to the Repeat Condition Screen mentioned above. If no wavelength has been selected, an error message appears which then returns the settings to their initial settings.



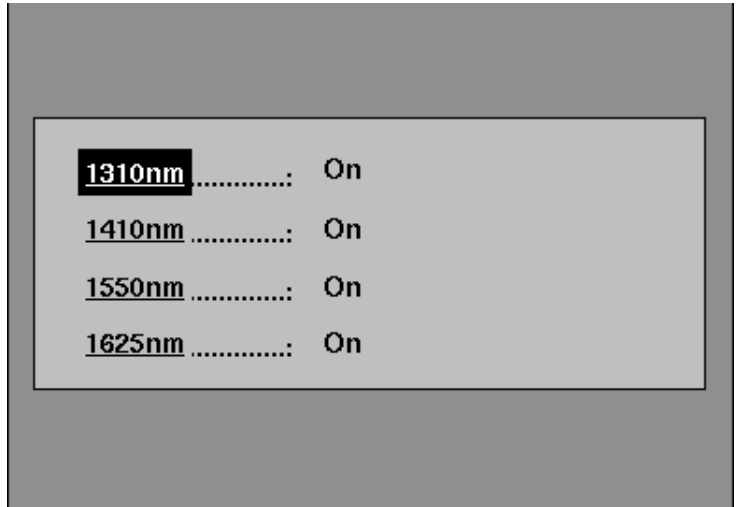

Figure Dialog Box



Figure Dialog Box for Wavelength Selection

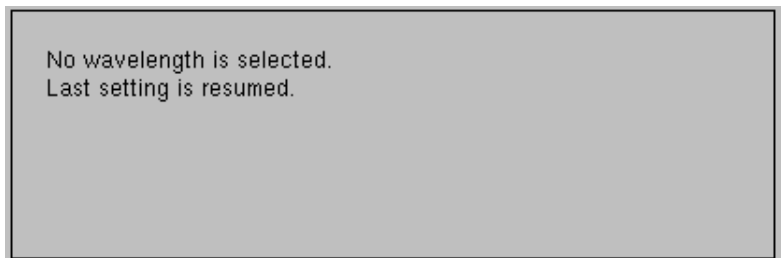

Figure Error Message

## Section 4 Operation (OTDR Measurement)

---

**Event** Displays the event point search method. Auto Search is set on the previous page. If Fixed is set, Fix is displayed. To fix an event point, select Fix.

**File Type** Set the file format (Standard/Standard.V2/Analysis) of the file to be saved.

**File Compression** Set whether to compress the file to be saved.  
On: Compressed  
Off: Not compressed

**Media** Select the media in which the file is to be saved.  
Refer to “Section 7.2.1 Save” for the method of selecting the media.

**Directory** Set the directory in which data is to be saved.  
Refer to “Section 7.2.1 Save” for the method of specifying the directory.

**File Name** Set the file name in which the measurement result for each waveform is to be saved and the file name of the measurement log file. Refer to “Section 7.2.1 Save” for the method of setting the file name.

**Print** Set whether to print the measurement results.  
On: Printed  
Off: Not printed

Press  after the setting is completed. Continuous measurement is started.

After the measurement is completed, the Measurement Log Table shown in “Section 4.9.6 Reading the measurement result” appears. The measurement log table is displayed even if the measurements are suspended.

### 4.9.6 Reading the measurement result

After the measurement is completed, the Measurement screen is changed to the Measurement Log Table screen (see the figure below).

File name	Splice(dB)	R.Loss	dB/km	T.Loss(dB)	nm
0005.DAT	***.***	**.*	0.328	2.931	1310
1005.DAT	***.***	**.*	0.229	2.043	1550
2005.DAT	0.777	**.*	0.260	2.689	1625
0006.DAT	***.***	**.*	0.359	3.202	1310
1006.DAT	0.351	**.*	0.212	2.233	1550
2006.DAT	0.775	**.*	0.262	2.878	1625

In the measurement log table, the measured data is controlled for each file name and the maximum value of each measurement result is displayed. Splice Loss, Return Loss, Fiber Loss (dB/km), Total Loss, and wavelength are displayed as measurement results (see the figure above).

For a measurement result that exceeds the Warning Level set on the Setup screen, the background color of the data in question is changed to indicate a Warning.

The cursor can be moved by pressing the  $\wedge$  and  $\vee$  keys in the measurement log table so that a specific measurement log in the table can be selected.

#### Sort

File names displayed in the Measurement Log Table are sorted in the specified order. Function key items displayed by pressing  $\text{F1}$  (Sort) are as shown below. Select the desired item order:

- Splice (F1)
- Return Loss (F2)
- dB/km (F3)
- Total Loss (F4)
- Measure (F5)

#### Repeat Condition

The condition setting screen for repeat task is resumed.

#### Recall

By pressing  $\text{F3}$  (Recall) after moving the cursor onto the specific log by using the  $\wedge$  or  $\vee$  keys, the measurement waveform is displayed on the screen. Doing this allows the details of measured result to be checked.

### Print

Files selected in the Measurement Log Table or the file name list are printed. By pressing **F4** (Print), the following function keys are displayed:

#### Print Execute (F1)

By pressing **F1** (Print Execute) after selecting the file with the **F2** key (Select/Cancel), the screen is displayed to select print contents. Press **F1** (Print Execute) again after selecting the content. For the print content, see "7.1.1 Printing".

#### Select/Cancel (F2)

Selection is made by pressing **F2** (Select/Cancel) after placing the cursor on the file to be printed. The selected file name is displayed in bold type. The selection is cancelled by placing the cursor on the file name selected again and pressing **F2** (Select/Cancel).

#### Select All/Cancel All (F3)

All files in the table are printed by pressing **F3** (Select All). All selections are cancelled by pressing **F3** (Cancel All).

#### Table Print Execute (F4)

Print the measurement log table.

#### Exit (F5)

The print is stopped.

### 4.9.7 Constraints

The constraints regarding the use of Repeat Task function are shown below.

- (1) Up to 500 measurement results can be stored in the measurement log table.
- (2) If the measurement result file does not exist in the specified media or directory, the measurement waveform cannot be recalled from the measurement log table.
- (3) If a print output error occurs when continuous measurements are being executed with the print output set to ON, the subsequent measurement is suspended.
- (4) If Auto Power Off is activated during continuous measurement due to the shortage of remaining battery, the data measured at this time is not guaranteed. Before making continuous measurements, connect the AC adapter or charge the battery.
- (5) The return loss of the fiber end isn't displayed.
- (6) When the Measurement Log Table is displayed and the distance unit is changed, the value of "dB/km" is rounded off. Accordingly, it may be influenced by the error.

## 4.10 Relative Distance Measurement

In the relative distance measurement, data is calculated or displayed by setting the relative measurement cursor (zero cursor) to 0 km. This function is effective when a dummy fiber is used before the test fiber or when measurements are made from a specific event point.

The distance to each marker, the values of Total Loss and Total Return Loss displayed in the event table are displayed and calculated with the relative measurement cursor as reference.

When the waveform is not displayed, the zero cursor can be set.

Press **Menu** on the measurement end screen to open the menu window.

Select Display with the **▲** and **▼** keys.

When Display is selected, H Offset is displayed at the function key label F2.

When **F2** (H Offset) is pressed, the distance of the zero cursor is displayed at the bottom of the screen, and the zero cursor is displayed on the waveform screen.

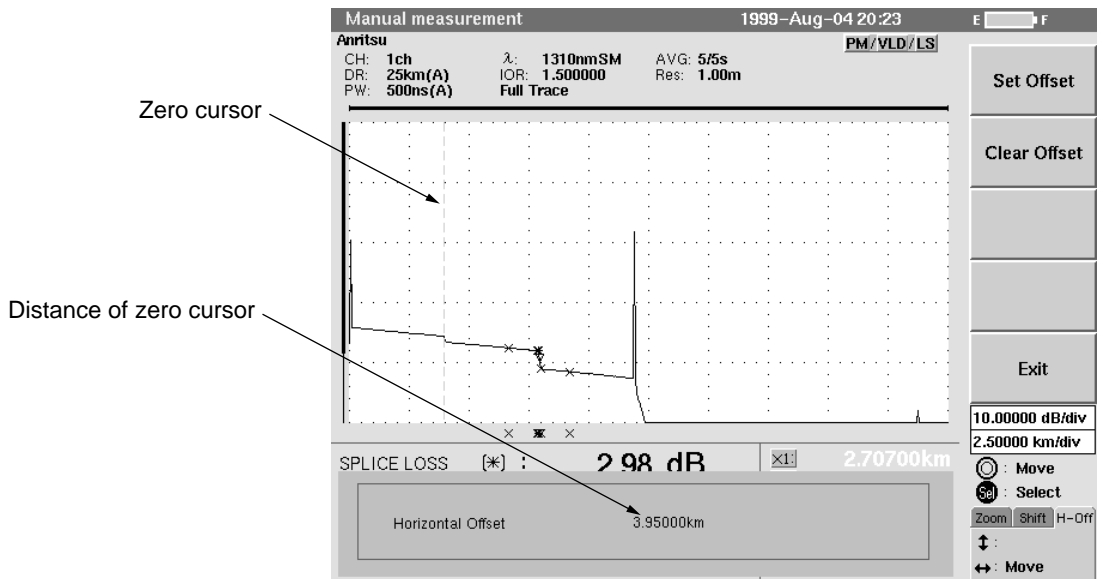

The zero cursor can be moved with the **<** and **>** keys or the rotary knob and its position is set by pressing **F1** (Set Offset).

When **F2** (Clear Offset) is pressed, the zero cursor setting is canceled, and the zero cursor is erased.

## Section 4 Operation (OTDR Measurement)

When the zero cursor is set, the distance display of the marker is changed to that from the zero cursor.

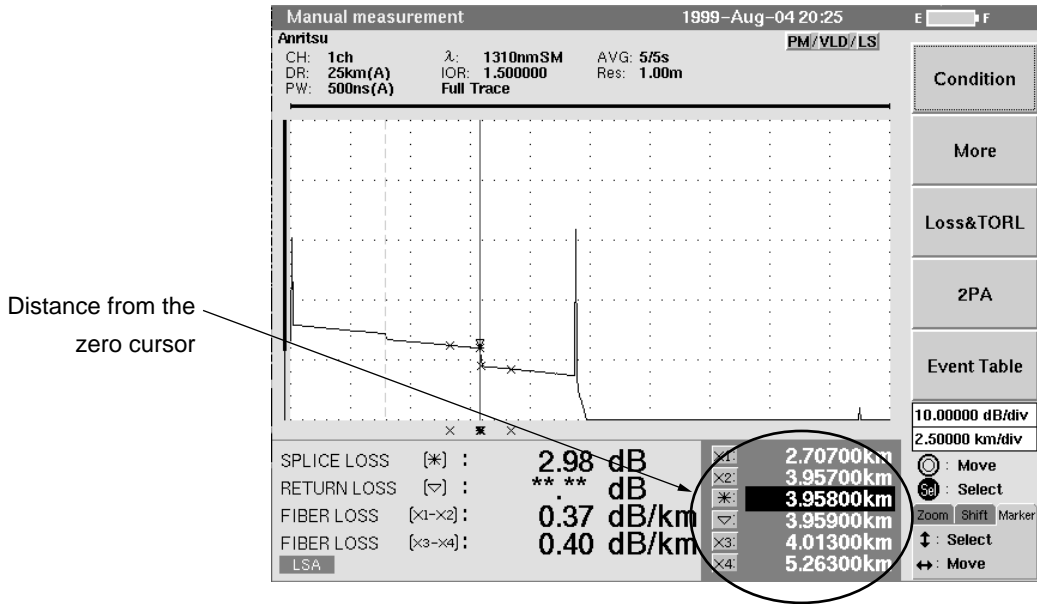

### Constraints for relative distance measurement

- (1) The zero cursor cannot be set when the waveform is not displayed.
- (2) If the distance range is changed after the zero cursor is set and the cursor falls outside the distance range, relative measurement is canceled automatically.

## 4.11 Comparing Waveforms

### Waveform comparison function

To monitor the aging of the fiber optic cable, waveforms at installation and those now measured are compared.

This function is able to read the previously measured waveform as the reference waveform for MW9076. The reference waveform remains displayed on the MW9076 monitor during measurement. This function displays the difference between the measured and reference waveforms, thus the difference in distance and level easily observable. This makes it convenient to monitor aging or compare multiple fibers.

The two waveforms displayed are called the reference waveform and the current waveform.

The current waveform can be measured again after changing the measurement conditions. The marker moves on the current waveform, thus the displayed measurement result is that for the current waveform. The current waveform can also be saved or recalled.

Though the reference waveform is displayed on the same scale as the current waveform, measurement conditions cannot be changed and it cannot be measured again.

### Using/quitting the waveform comparison function

While MW9076 is in the OTDR mode, press **Menu** to open the menu window. Select “Application” using **^**, **v** keys. (This menu is not displayed when CD, OLTS or Repeat Task are being executed.)

When “Application” is selected, “Trace compare” is displayed on the F2 function key label. Pressing **F2** (Trace compare) displays a file selection screen as shown in the next page.

Move the cursor on the filename to be read using **^**, **v** or the rotary knob.

After moving the cursor, press **F2** (Reference Recall Exec).

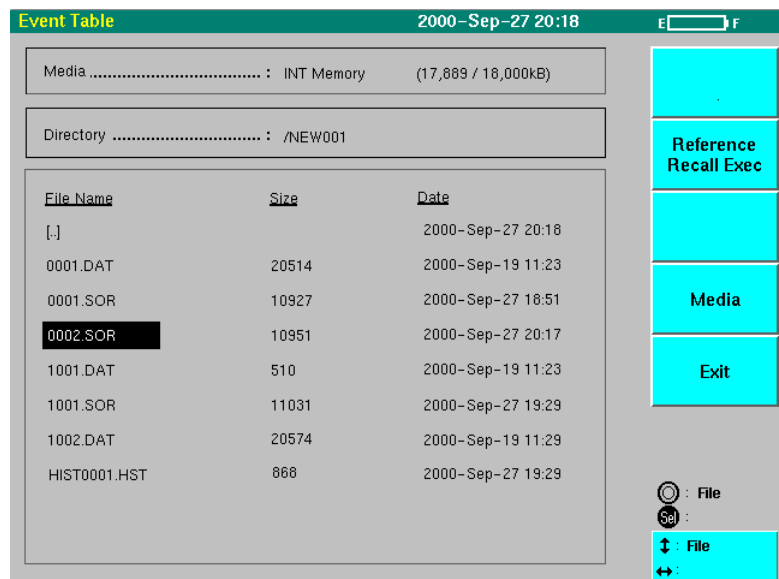

## Section 4 Operation (OTDR Measurement)

When **F2** (Reference Recall Exec) is pressed, MW9076 displays the following message:

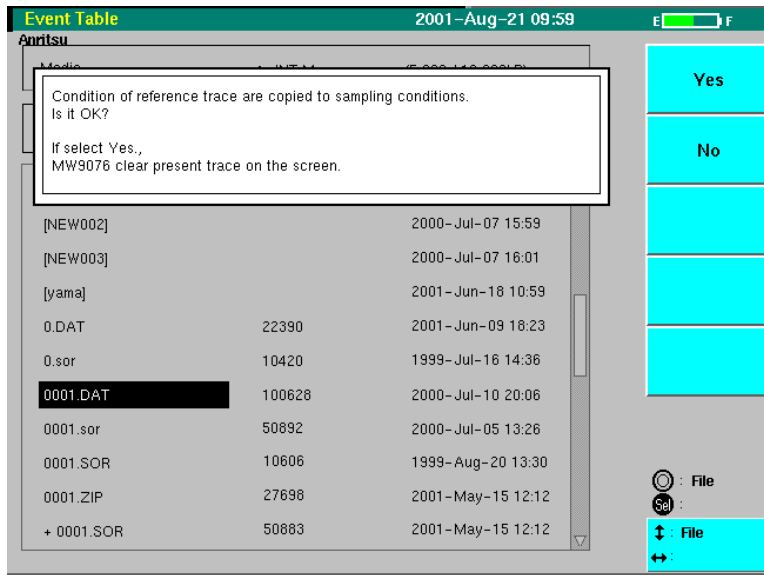

To measure using the same conditions as the selected waveform, press **F1** (Yes). The selected file is read as the reference waveform and also the current waveform for MW9076.

To compare with the waveform already displayed on MW9076, press **F2** (No). The displayed waveform is left as it is and the reference waveform is read for OTDR.

When the waveform comparison function is turned on, the following screen is displayed:

The marker is displayed on the current waveform and can be moved, but cannot be displayed on the reference waveform. Measurement results for the current waveform are displayed in the measurement results display area at the bottom of the screen.

Turning on the waveform comparison function also displays two vertical axis bars that indicate the display position on the vertical axis. The left one is for the current waveform and the right one is for the reference waveform. When the current waveform is not displayed (no longer appears after switching the distance range or wavelength), the left vertical axis bar for the current waveform also does not appear. It will reappear when the waveform is displayed.



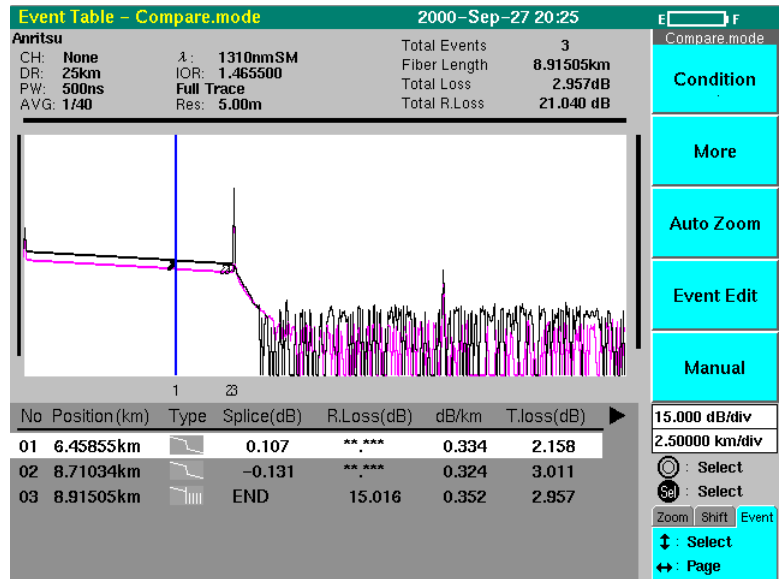

To turn off the waveform comparison function, press **Menu** to open the menu window. Select “Application” using **^**, **v** keys. When “Application” is selected, “Compare off” is displayed on the F1 function key label. Pressing **F1** (Compare off) turns off the waveform comparison function.

When the waveform comparison function is quit, the vertical axis bar for the reference waveform displayed on the right side of the screen is disappeared and exits from the waveform comparison function.

### Waveform difference display

To display the waveform difference, first set the waveform comparison function on and display the reference and current waveforms. If multiple current waveforms are displayed, choose one. (When multiple wavelengths are chosen in Setup at one time, and measured or multiple files are read all at once, multiple current waveforms may be displayed.) Next, select “Menu” to open the menu window. By choosing “Application” with **^**, **v** “Difference Waveform” is displayed in F2 function key label. Pressing **F2** (Difference Waveform) shows the waveform difference screen below.

On the waveform difference display, only one marker is displayed. The difference between the current and reference waveforms at the marker position is displayed in the measurement results area.

The waveform difference is calculated using the formula  
: (current waveform) - (reference waveform).

## Section 4 Operation (OTDR Measurement)

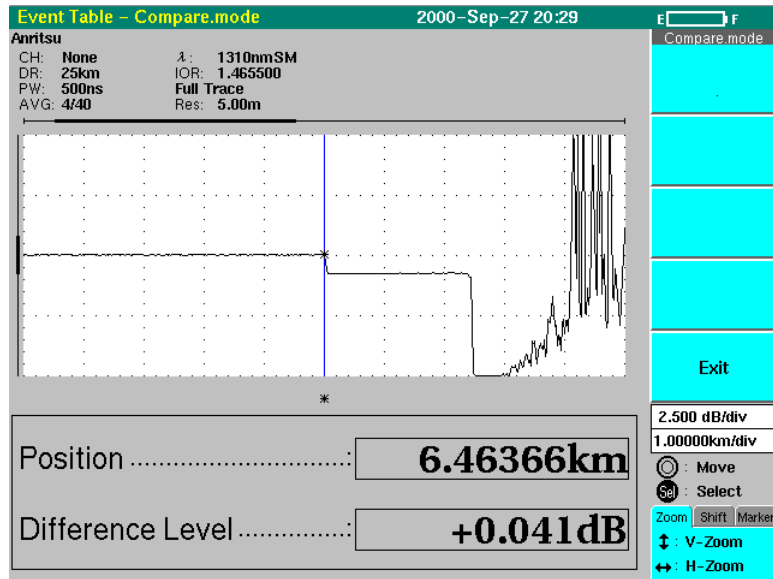

To return from the waveform difference screen to the waveform comparison screen, press **F5** (Exit).

**Note:**

To select one of the multiple current waveforms displayed, press **F2** (More) and then press **F4** (MultiTrace) on the next page to display the multiple waveforms operation function. Pressing **F1** (Select Trace) switches the selected waveform.

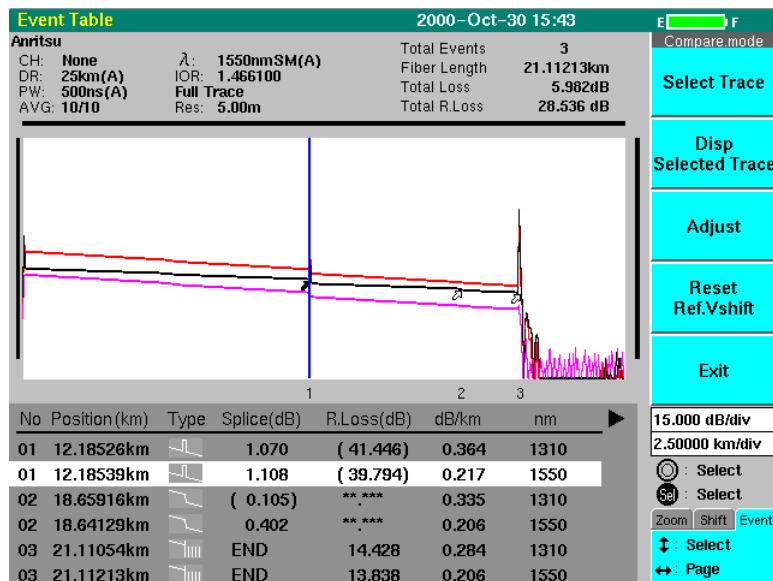

In the waveform difference display, some functions are disabled. Such functions are listed below:

- Reading/writing initial conditions
- Setting measurement conditions on the Setup screen
- Preview
- Manual measurements (measurements on the manual screen)
- Event measurements (measurements in the event table and auto zoom screens)
- Saving waveforms
- Repeat Task function

### Reading the reference waveform

To change the reference waveform in the waveform comparison mode, read it. The reference waveform is read by operating the keys shown below. It cannot be recorded.

To read the reference waveform in the waveform comparison mode, press **Menu** to open the menu window. Select "File" using **▲**, **▼** keys. When "File" is selected, "Recall" is displayed on the **F2** function key label. Pressing **F2** (Recall) displays the waveform Recall screen shown in the figure next page. Move the cursor on the filename to be read using **▲**, **▼** or the rotary knob. After moving the cursor, press **F2** (Reference Recall Exce). Subsequent operation is the same as when first starting the waveform comparison function.

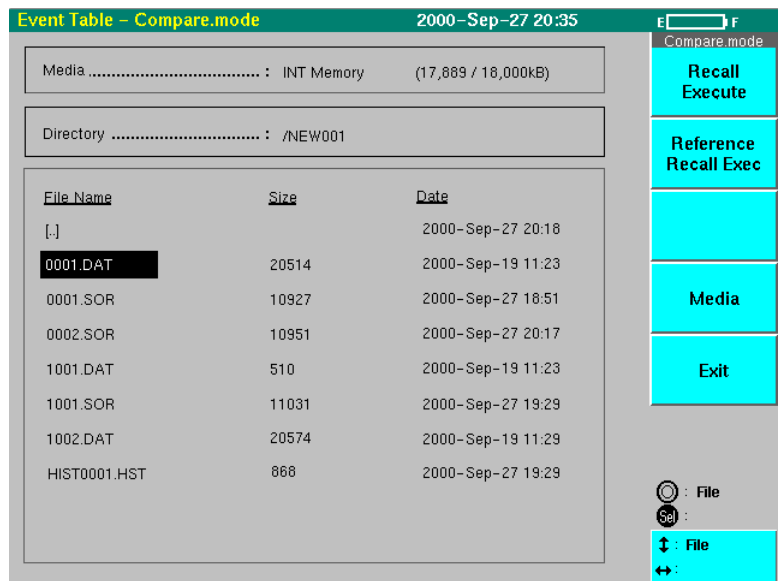

### Vertically shifting the reference waveform

To shift the reference waveform vertically, first press **F2** (More) on the waveform comparison screen to display the functions on the next page. Pressing **F3** (Reference Trace) here displays the message shown on the next page. At this time, press **▲**, **▼** while pressing **F3** to shift the reference waveform vertically.

To cancel vertical shifting and return to the initial state, press **F4** (Reset Ref. V shift).

## Section 4 Operation (OTDR Measurement)

When multiple current waveforms are displayed, press **F2** (More) to display the functions on the next page. Then press **F4** (Multi Trace operation) to display the multiple waveform operation function. For this function, **F4** (Reset Ref. V shift) is displayed.

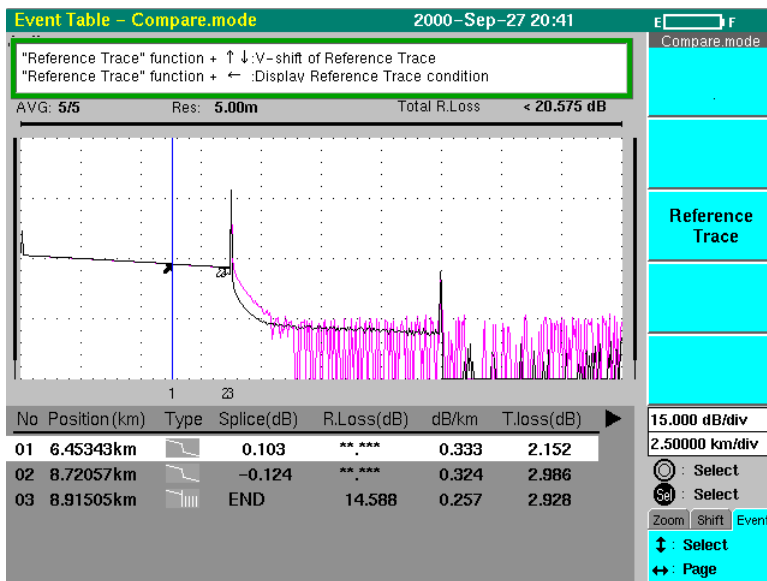

### Displaying measurement conditions for the reference waveform

To display the measurement conditions for the reference waveform, first press **F2** (More) on the waveform comparison screen to display the functions on the next page. Pressing **F3** (Reference Trace) here displays the same message as that for vertical shifting.

At this time, press **<** while pressing **F3** to display the measurement conditions for the reference waveform.

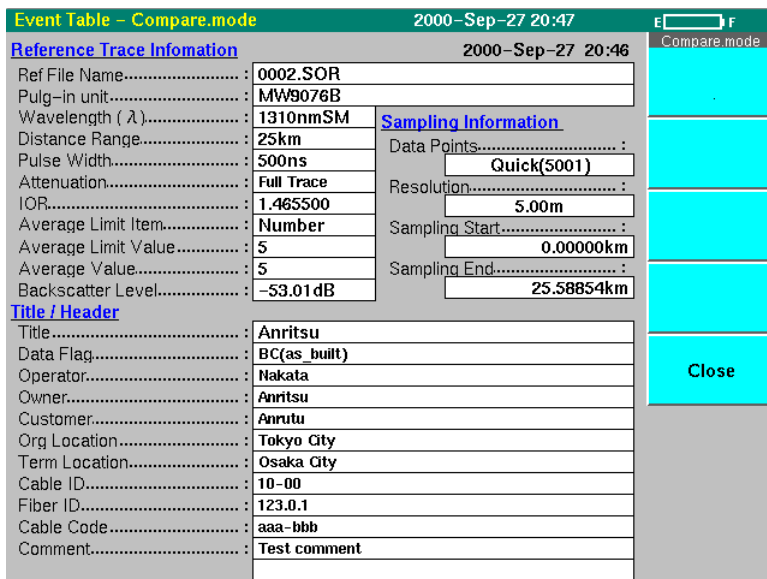

## 4.12 Measurement Examples

Before performing the measurements using the measurement examples explained in the following sections, it is necessary to set the OTDR as shown below.

- (1) Turn on the power switch and make sure that the Setup screen is correctly displayed.
- (2) Set the measurement mode to manual on the Setup screen.
- (3) Select the measurement wavelength on the Setup screen.
- (4) Set the distance range (Distance) to 10 km on the Setup screen.
- (5) Set the pulse width (Pulse Width) to 100 ns on the Setup screen.
- (6) Set the index of the refraction (IOR) of the test optical fiber on the Setup screen.
- (7) Exit the Setup screen and enter the Loss Display screen.

See “Appendix I Simple OTDR Operation Method” for more information.

### CAUTION

---

**The OTDR outputs high-power optical pulses. Please disconnect the communication equipments from the optical fibers before measurement in case that the optical sensor breaks.**

---

### 4.12.1 Measuring the absolute distance

The distance from the OTDR to the marker is measured.

#### Setup

Connect the units as shown below.

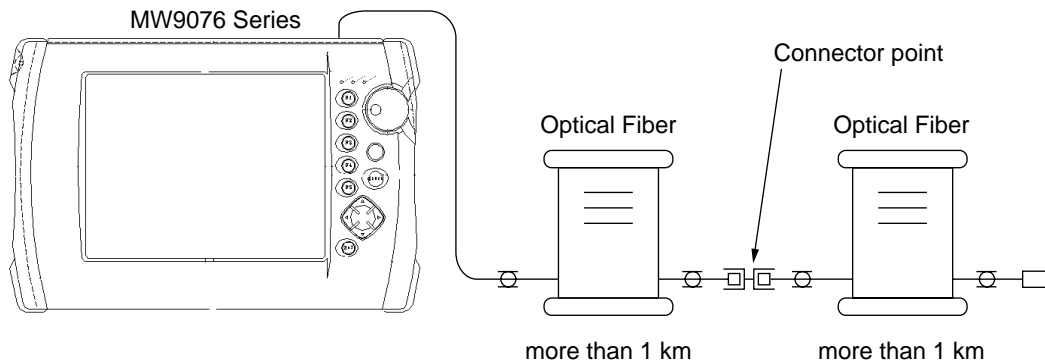

The maximum cable length in this setup is 10 km.

#### Measurement procedure

- (1) Press **Start**.
- (2) Set the \* marker to the connector point or to the end of the fiber.

#### Note:

When measuring the distance to the connector points, set the marker on the change point closer to the OTDR of the waveform. Refer to “Section 4.6.1 How to perform an accurate measurement.”

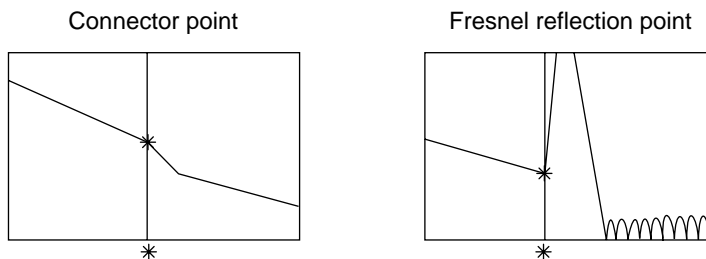

- (3) Enlarge both the horizontal and vertical scale to the maximum.
- (4) If a large amount of noise is present, set Averaging to ON on the Setup screen, and then perform the measurement again.
- (5) Position the cursor exactly at the fault.
- (6) The distance of the \* marker displayed at the bottom of the screen is the distance from the OTDR to the \* marker.

## 4.12.2 Measuring the relative distance

The distance between markers is measured.

### Setup

Connect the units as shown below.

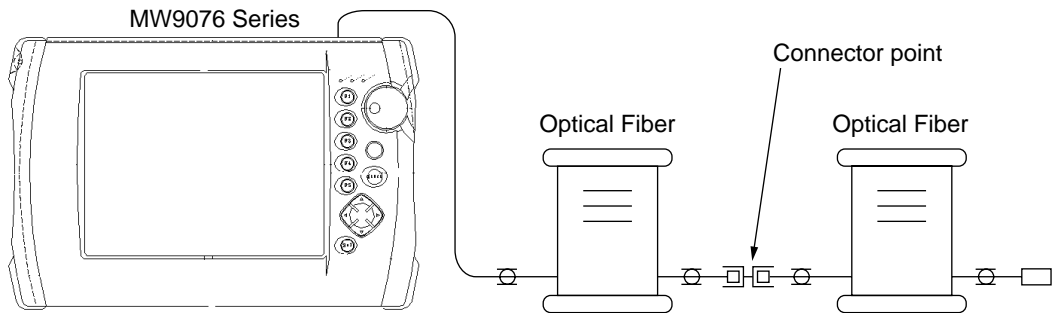

The maximum cable length in this setup is 10 km.

### Measurement procedure.

- (1) Press **Start**.
- (2) Press **Select** to put the card with the Marker on the tag, which is displayed at the bottom right of the screen, at the front of the card pile. The marker can be moved with the **<** and **>** keys.
- (3) Select the × marker with the **^** and **v** keys.
- (4) Use the **<** and **>** keys to position the × marker on the rising edge of the Fresnel reflection that appears at the connection between the dummy fiber and the test fiber. Press **Select** to put the Zoom card at the front of the card pile, and use the cursor keys to scale up the screen. Press **Select** once again to put the Marker card at the front of the pile and position the marker exactly at the rising edge of the trace.

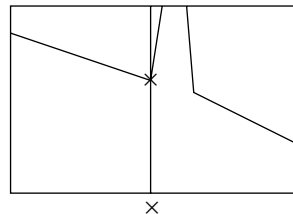

- (5) Press **Select** to put the Zoom card at the front of the card pile and scale down the screen with the cursor keys so that the Fresnel reflection at the cable end is displayed.
- (6) Press **Select** to put the Marker card at the front of the card pile and select the \* marker with the **^** and **v** keys.

## Section 4 Operation (OTDR Measurement)

- (7) Use the  $\langle$  and  $\rangle$  keys to position the \* marker at the rising edge of the Fresnel reflection that appears at the end of the cable.

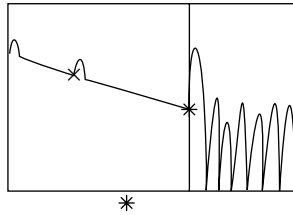

- (8) Press **Select** to put the Zoom card at the front of the card pile and use the cursor keys to scale up the screen. Press **Select** once again to put the Marker card at the front of the pile and position the marker exactly at the rising edge of the trace.

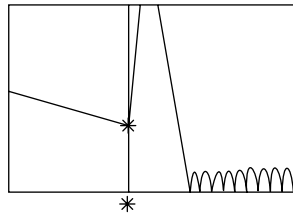

- (9) If a large amount of noise is present, set Averaging to ON on the Setup screen, and then perform the measurement again.
- (10) The value indicated under Distance on the screen when the \* marker is set, is the distance between the markers.

### Note:

When performing a measurement, be careful about the generation of ghost waves. Ghosts are generated when the reflected light from a connector is reflected again at the OTDR. The waveform of the reflected light as a ghost at twice the distance to the connector “d.” To eliminate ghosts, decrease the reflection by adjusting the connections of the connector, applying grease at the connecting face of the cable, or taking other measures.

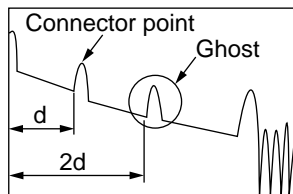



### 4.12.3 Measuring the connection loss (splice)

The connection loss of a splice in the fiber is measured.

#### Setup

Connect the units as shown below.

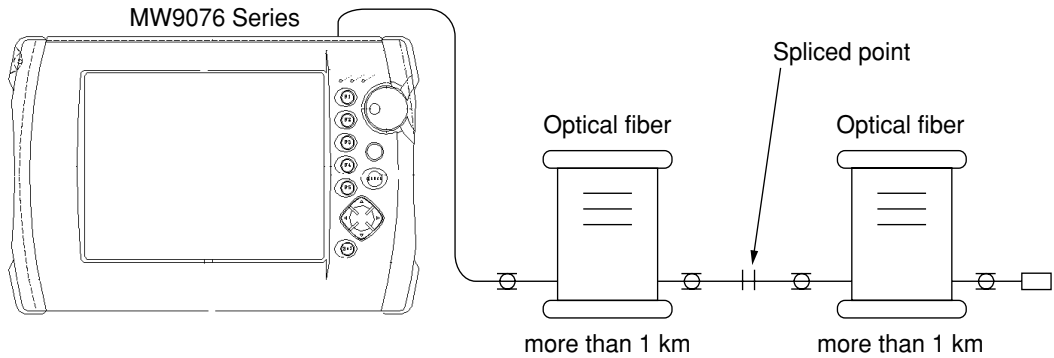

#### Measurement procedure

- (1) Press **Start**. After the measurement is completed, set the \* marker at the beginning of the splice step closer to the OTDR.
- (2) Position the splice at the center of the screen and zoom up in such a manner that as far as possible, the maximum length of the straight sections ((L1) and (L2) in the figure below) of the fiber before and after the splice are included in the screen and no other splices, connections, and fault points are included on the screen.

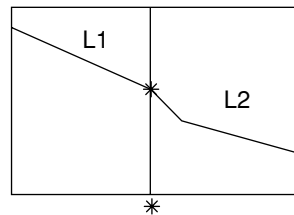

- (3) Set "Averaging" to ON and start measurement again, then wait until a smooth trace is obtained.
- (4) Press **F3** (Splice & Return Loss) to enter the Splice & Return Loss mode.
- (5) Press **F4** (LSA) to set the linear approximation method to LSA.
- (6) The splice loss is displayed at the bottom left of the screen.

**Note:**

When a splice other than the target splice or Fresnel reflection is displayed on the screen between two × markers, move the outermost × marker to the inside point as shown below so that another splice or Fresnel reflection is not included between the two × markers. In this case, the distance between the two × markers should be as long as possible.

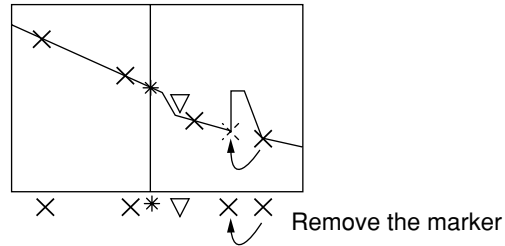

**4.12.4 Measuring the connection loss (connector)**

The connection loss of a connector in the fiber is measured.

**Setup**

Connect the units as shown below.

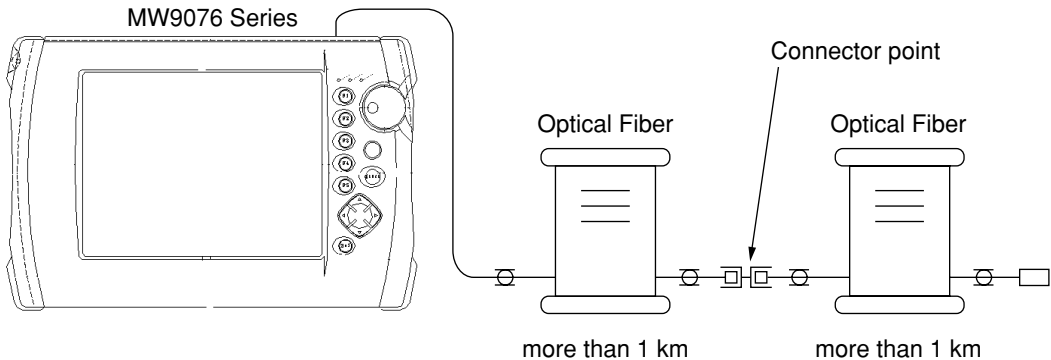

**Measurement procedure**

- (1) Press **Start**. After the measurement is completed, set the \* marker at the rising edge of the Fresnel reflection.
- (2) Position the Fresnel reflection point at the center of the screen in such a manner that as long as possible, the maximum length of the straight sections (L1) and (L2) of the fiber before and after the point are included in the screen and no other splices, connections, and fault points are included on the screen.

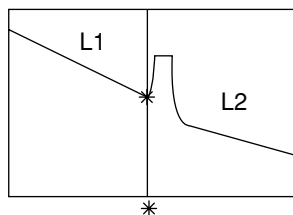

- (3) Set “Averaging” to ON and start measurement again, then wait until a smooth trace is obtained.
- (4) Press **F3** (Splice & Return Loss) to enter the Splice & Return Loss mode.
- (5) Press **F4** (LSA) to set the linear approximation method to LSA.
- (6) The connector loss is displayed at the bottom left of the screen.

**Note:**

When a splice other than the target connector or Fresnel reflection is displayed on the screen between two × markers, move the outermost × marker to the inside point as shown below so that another connector or Fresnel reflection is not included between the two × markers. In this case, the distance between the two × markers should be as long as possible.

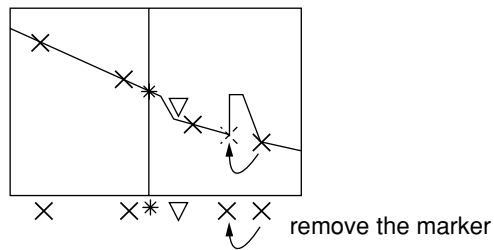

### 4.12.5 Measuring the transmission loss

The optical fiber transmission loss is measured.

#### Setup

Connect the units as shown below.

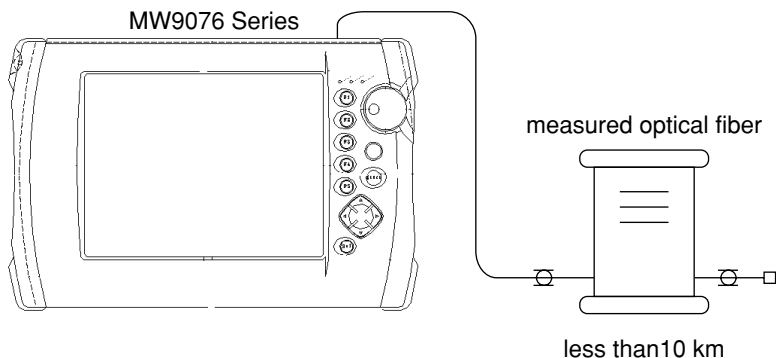

#### Measurement procedure

- (1) Press **Start**.
- (2) Press **Select** to put the Zoom card at the front of the card pile and use the cursor keys to scale up the screen so that the entire trace waveform is displayed on the screen.
- (3) Set “Averaging” to ON and start measurement again, then wait until a smooth trace is obtained.
- (4) Press **F3** (Loss & TORL) to set the Loss and Total Return Loss Mode.
- (5) Press **F4** (LSA) to set the linear approximation method to LSA.
- (6) Set the × marker at the near end of the fiber and the \* marker at the rising edge of the Fresnel reflection at the far end of the cable as shown below.

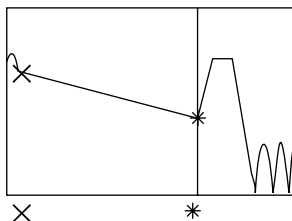

- (7) The transmission loss is displayed under LOSS at the bottom left of the screen.

### 4.12.6 Measuring the return loss

The return loss of the connector is measured.

#### Setup

Connect the units as shown below.

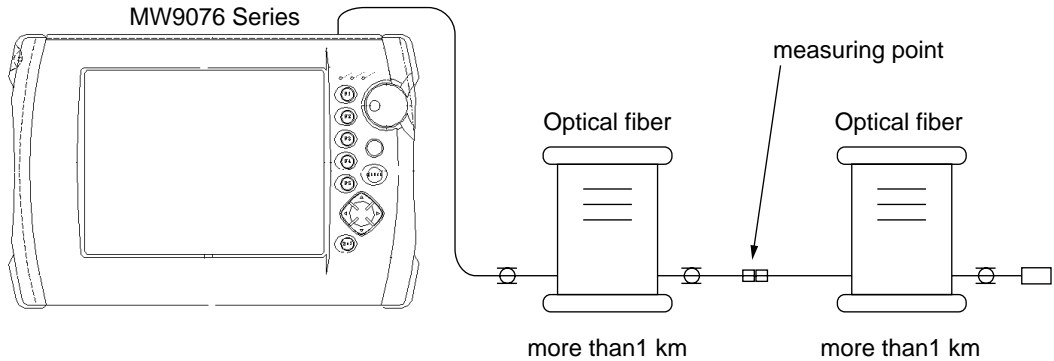

#### Measurement procedure

- (1) Press **Start**.
- (2) Set the Splice & Return Loss mode.
- (3) Set the  $\nabla$  marker on the peak of the Fresnel reflection for the connector under test. Put the Zoom card at the front of the card pile and scale up the horizontal and vertical scales with the cursor keys so that the  $\nabla$  marker can be accurately positioned.

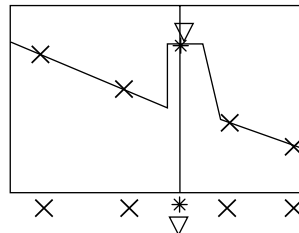

- (4) Display the Marker card at the front of the card pile by pressing **Select**, and select the \* marker with the cursor keys. Position the \* marker at the rising edge of the Fresnel reflection as shown below.

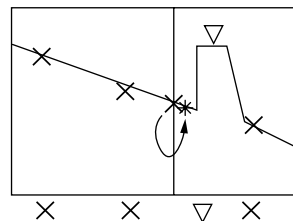

- (5) If a large amount of noise is present in the trace, set Averaging to ON.
- (6) The return loss is displayed under RETURN LOSS at the bottom left of the screen.



# Section 5 Operation (OLTS Measurement)

---

This section explains how to operate the OTDR with the OLTS measurement as an example.  in this section indicates a panel key.

5.1	OLTS Function .....	5-2
5.2	Setup .....	5-3
	5.2.1 More (OLTS) .....	5-9
5.3	Loss Table .....	5-10
5.4	Measurement Example (Optical Loss Measurement) .....	5-13

## 5.1 OLTS Function

The OTDR can measure the loss of the fiber under test by using a light source and an optical power meter (optional). A measurement made by using the light source and the optical power meter in combination is called the Optical Loss Test Set (OLTS).

OLTS measurements can be made only with the MW9076B/B1/C OTDR main unit equipped with Option 02 or 03. But the MW9076B1 has only the optical power meter function. (No light source function.)

With the OLTS function, the loss of the fiber under test can be easily measured by connecting the fiber under test to a light source and an optical power meter. Note that the optical power A of the light source should have been measured in advance. When this optical power A is entered as the reference value, the loss of the fiber or other devices under test is displayed as the measurement result.

Note that a measurement cannot be made on a multi-mode fiber.

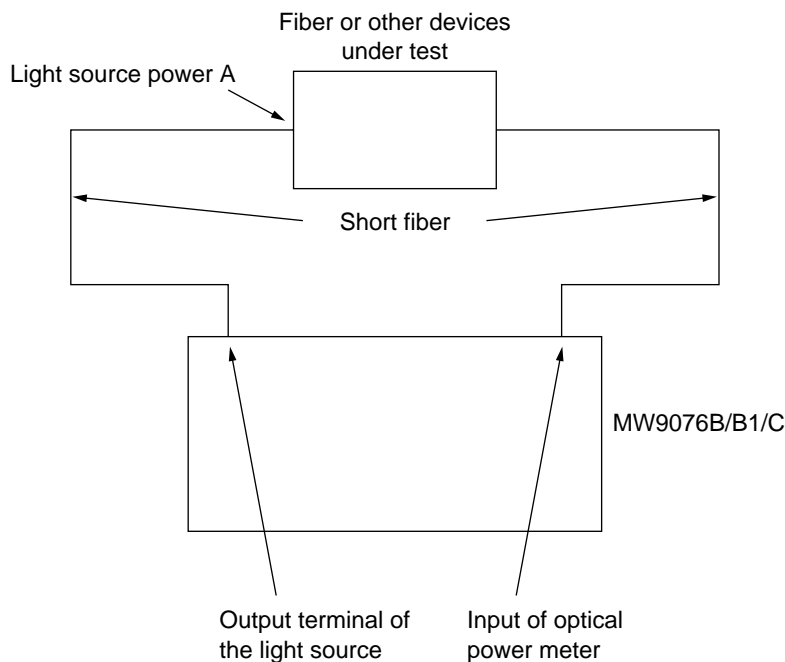

The reference value, absolute value, and loss are displayed in this order on the lower half of the OLTS screen. The loss is calculated by subtracting the absolute value from the reference value.



## 5.2 Setup

### From the OTDR measurement to the OLTS measurement

Display Setup screen 1 from the OTDR measurement.

When System is selected on Setup screen 1, the following window is opened.

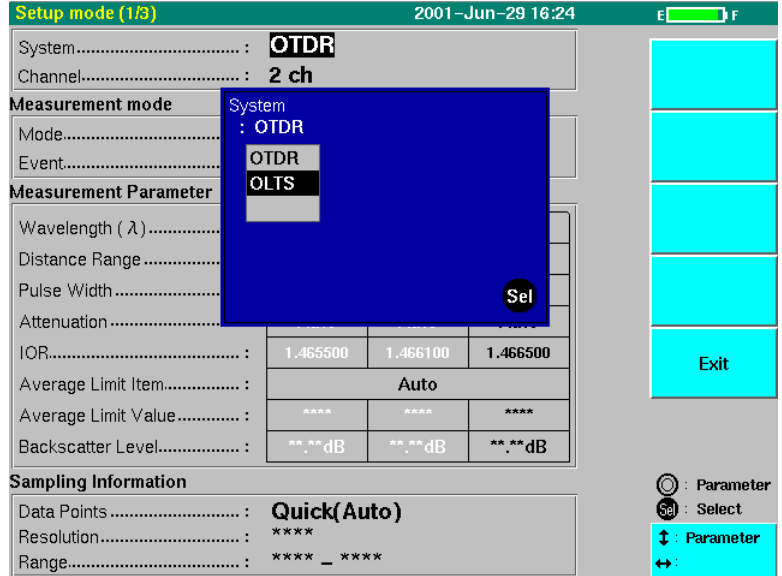

When OLTS is selected and **Select** is pressed, the system enters the OLTS measurement mode.

After entering the OLTS measurement mode, the screen shown on the next page is displayed.

**Setting the OLTS measurement**

When moving from the OTDR measurement to the OLTS measurement, the following screen is displayed:

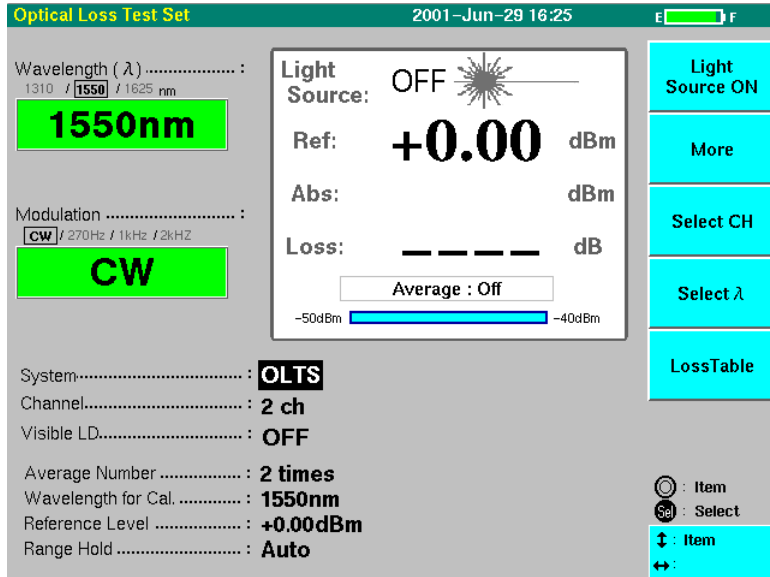

When the optional Optical Power Meter is not mounted, the screen is displayed to enable light source function operations only. MW9076B1 disables the transition to the OLTS measurement when the optical power meter is not mounted.

**Wavelength**

Switch the wavelength of the light source and optical power meter. The wavelength that can be selected is determined by the mounted OTDR unit (The optical power meter wavelength is selected when the main unit is MW9076B1 as there is no light source function,). The light source and the optical power meter are switched together.

Press **F4** (Select λ) to switch the wavelength. Press **Select** or the rotary knob with the cursor placed on "Wavelength" to display the selection dialog box as shown below to enable selection. Use the **^** and **v** keys or the rotary knob to move the cursor to select the wavelength and use **Select** to determine the selection. In addition, when the cursor is placed on "Wavelength", press the **<** and **>** keys to switch the wavelengths.

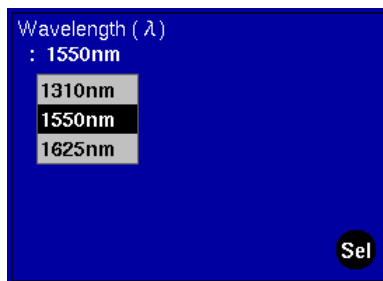

**Modulation**

Switch the modulation frequencies (CW/270 Hz/1 kHz/2 kHz) of the light source and optical power meter. The light source and the optical power meter are switched together. Switching is performed by adjusting the desired frequency using the **<** and **>** keys with the cursor placed on "Modulation". In addition, press **Select** or the rotary knob with the cursor placed on "Modulation" to display the selection dialog box as shown below to enable selection. Use the **^** and **v** keys or the rotary knob to move the cursor to select the wavelength and use **Select** to determine the selection.

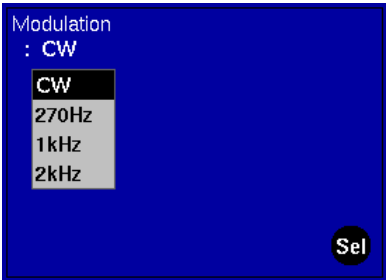

**System**

The measurement system is changed to OTDR measurement.

**Channel**

Set the channel number of connected optical channel selector. The channel number that can be set is determined by the connected optical channel selector. To set the channel, switch the channel to the desired one by pressing the **<** and **>** keys with the cursor placed on "Channel". In addition, press **Select** or the rotary knob with the cursor placed on "Channel" to display the selection dialog box as shown below to enable selection. Use the **^** and **v** keys or the rotary knob to display the channel and use **Select** to determine the selection.

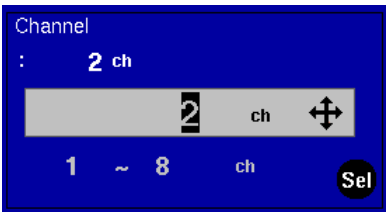

### Visible LD

When the optional visible light source is mounted, OFF/ON/Blink can be set. To set the visible light source, press **Select** or the rotary knob with the cursor placed on "Visible LD" to display the selection dialog box as shown below to enable selection. Use the **^** and **v** keys or the rotary knob to select the desired operation and use **Select** to determine the selection.



### Average Number

Set the average number for the optical power measurement. When the input power fluctuates and the range is switched during the average process, the average process is reset and is executed again.

To set the average number, switch the average number to the desired one by pressing the **<** and **>** keys with the cursor placed on "Average Number". In addition, Press **Select** or the rotary knob with the cursor placed on "Average Number" to display the selection dialog box as shown below to enable selection. Use the **^** and **v** keys or the rotary knob to change the average number to the desired one and use **Select** to determine the selection. To turn the average ON and OFF, press **F4** (Average ON) after pressing **F2** (More).

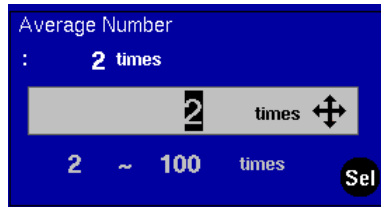

### Wavelength for Calibration

To calibrate the optical power meter sensitivity, set the incident light wavelength. It can be set at the 5 nm interval. The wavelength is changed to the desired one by using the **<** and **>** keys with the cursor placed on "Wavelength for Cal.". In addition, press **Select** or the rotary knob with the cursor placed on "Wavelength for Cal." to display the selection dialog box as shown below to enable selection. Use the **^** and **v** keys or the rotary knob to select the desired wavelength and press **Select** to determine the selection.

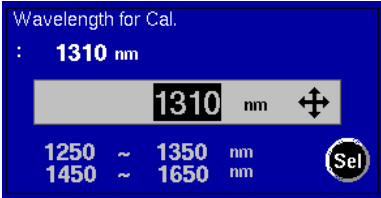

Each wavelength can be calibrated in the following wavelength ranges:  
 1250 to 1350 nm, 1450 to 1650 nm

**Reference Level**

The reference level for the relative power measurement is set. The reference level can be set at the 0.01 dBm units. To set the reference level, press the (<) and (>) keys to change the value to the desired one with the cursor placed on "Reference Level". In addition, press (Select) or the rotary knob with the cursor placed on "Reference Level" to display the selection dialog box as shown below to enable selection. Use the (^) and (v) keys or the rotary knob to change the value to the desired one and press (Select) to determine the selection.



By pressing (F3) (Abs → Ref) during the measurement, the absolute value at that time is set as the reference level. (F3) (Abs → Ref) can be selected by using (F2) (More).

**Range Hold**

Switch the measurement range of the optical power meter. By setting Auto, the range is automatically optimized for the measurement according to the input power.

To set the range, press (Select) or the rotary knob when the cursor is placed on "Range Hold" to display the selection dialog box as shown below. Use the (^) and (v) keys or the rotary knob to select the desired range and press (Select) to determine it.

The following display is shown in the event of over range or under range. Check the measurement range and perform the measurement again.

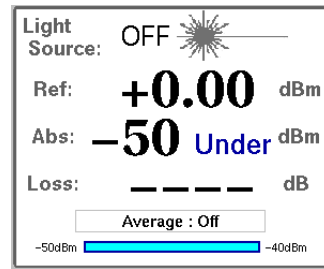
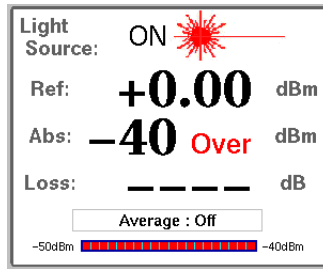
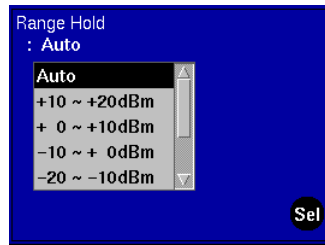

### Contents of function keys

#### Light Source ON (F1)

By pressing **F1** (Light Source ON), the light source set with "Waveform" illuminates. To stop the illumination, press **F1** (Light Source OFF) again. Only MW9076B/C supports this function.

#### More (F2)

By pressing **F2** (More), the following function keys are displayed. For details, see "5.2.1 More (OLTS)".

- Light Source ON (F1)
- Back (F2)
- Abs → Ref (F3)
- Average ON (F4)
- Offset (F5)

#### Select CH (F3)

By pressing **F3** (Select CH), the channel number of connected optical channel selector is incremented. Channel numbers that can be set are determined by the connected optical channel selector.

#### Select $\lambda$ (F4)

By pressing **F4** (Select  $\lambda$ ), wavelengths of the light source and the optical power meter are switched one by one (when the main unit is MW9076B1 the optical power meter wavelength is selected as there is no light source function.). The wavelengths that can be selected are determined by the mounted OTDR unit. The light source and the optical power meter are switched together.

#### Loss Table (F5)

The OLTS measurement loss table can be created. For details, see "5.3 Loss Table".

## 5.2.1 More (OLTS)

By pressing **F2** (More) in the OLTS measurement, the following function keys are displayed.

### Light Source ON (F1)

By pressing **F1** (Light Source ON), the light source set with "waveform" illuminates. To stop the illumination, press **F1** (Light Source OFF) again. Only MW9076B/C supports this function.

### Back (F2)

Function keys that are first displayed when displaying the OLTS mode are resumed.

### Absolute value → Reference value (F3)

Set the reference value for the relative power measurement. By pressing **F3** (Abs → Ref) during the OLTS measurement, the absolute value at that time is set as the reference value.

### Average ON (F4)

By pressing **F4** (Average ON), the measured value is averaged by using the number set as "Average Number". To stop the average process, press **F4** (Average OFF) again.

### Offset (F5)

To perform the OLTS measurement, first perform the offset adjustment of the optical power meter. Place the dust cover on the input end of the optical power meter to block the optical input before pressing **F5** (Offset). It takes about 20 seconds for the adjustment.

### 5.3 Loss Table

The loss table for OLTS measurement can be created. Display items of the table are measurement number, wavelength (nm), channel number, reference value (dBm), absolute value (dBm), and loss (dB). In addition, the created loss table can be saved to the file and printed. Press **F5** (Loss Table) on the OLTS measurement table to display the screen as shown below. Press **F1** (Add Table) to add the measured result at that time to the table. In addition, comments can be input for the result added to the table.

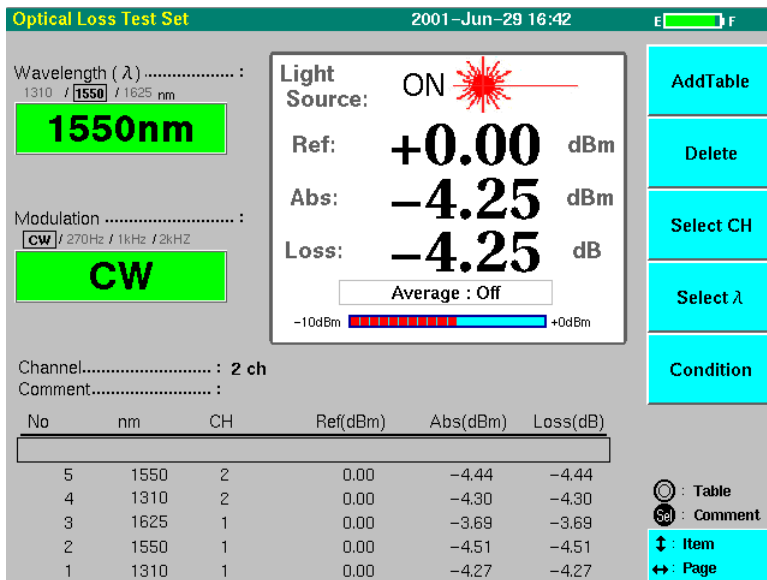

#### Function key contents

##### Add Table

By pressing **F1** (Add Table), the measured result at that time is added to the loss table. The procedures to insert a result in the middle of loss table already created are as follows:

- (1) Move the cursor to the insertion position  
Use the **^** and **v** keys or the rotary knob to move the cursor to the place in the table where you want to insert the result. When you want to insert the result between No. 5 and 6 for example, place the cursor on No. 6.
- (2) Add Table  
Press **F1** (Add Table) to insert the result. Since the cursor is still placed at the insertion position, it must be moved to the place where the next measurement result is added.



**Delete**

By pressing **F2** (Delete), the function key is displayed that is used to delete a result from the loss table.

**Delete Execute (F1)**

After selecting the file to be deleted by using **F2** (Select/Cancel) or **F3** (Select All), delete the required result from the loss table by pressing **F1** (Delete Execute).

**Select/Cancel (F2)**

Use the **∧** and **∨** keys or the rotary knob to move the cursor to the result that you want to delete from the loss table. When you select it by pressing **F2** (Select/Cancel), the selected result is displayed in bold type. When you want to cancel the selection, place the cursor there again and press **F2** (Select/Cancel). Press **F1** (Delete Execute) after the selection to delete the result.

**Select All (F3)**

To delete the entire loss table, press **F3** (Select All). Press **F1** (Delete Execute) after the selection, to delete the results.

**Exit (F5)**

The deletion is stopped.

**Select CH**

By pressing **F3** (Select CH), the channel number of the connected optical channel selector is incremented. The channel numbers that can be set are determined by the connected optical channel selector.

**Select  $\lambda$** 

By pressing **F4** (Select  $\lambda$ ), wavelengths of the light source and the optical power meter are switched one by one (The optical power meter wavelength is selected when the main unit is MW9076B1 as there is no light source function). The wavelengths that can be selected are determined by the mounted OTDR unit. The light source and the optical power meter are switched together.

### Condition

By pressing **F5** (Condition), the Loss Table screen returns to the OLTS measurement condition setting screen.

#### Comment input method

Comments can be input for each measured result in the loss table. Use the **^** and **v** keys or the rotary knob to select the result in the table and press **Select** to open the comment input window.

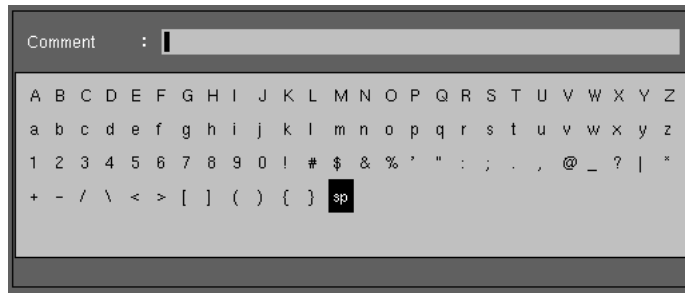

Use the **<** and **>** keys to move the cursor to the place where you want to input. Use the rotary knob to select the character you want to input. When you complete the input, press **F5** (Close). The input comment is determined and displayed next to "Comment" on the screen.

#### Function key contents

##### Insert (F1)

After pressing **F1** (Insert) at the position where the cursor is placed, the character is selected.

##### Delete (F2)

After placing the cursor on the character to be deleted, **F2** (Delete) is placed.

##### Paste Pre-Comment (F3)

The comment for measured result that is input immediately before is copied.

##### Clear (F4)

The input comment is cleared.

##### Close (F5)

The input is determined.

## 5.4 Measurement Example (Optical Loss Measurement)

The method of optical loss measurement is explained below as an example of the OLTS measurement.

The total loss of the fiber under test is measured. The optical power meter supports only the single mode fiber.

### Setup

- (1) Connect the short fibers between the light source and the optical power meter to measure the optical power at point (a) in the following figure.
- (2) Connect a short fiber between the output of the light source and one end of the fiber or other devices under test, and then connect the other end of the fiber under test and the input of the optical power meter with another short fiber. Measure the optical power at point (b) as shown in the figure below.

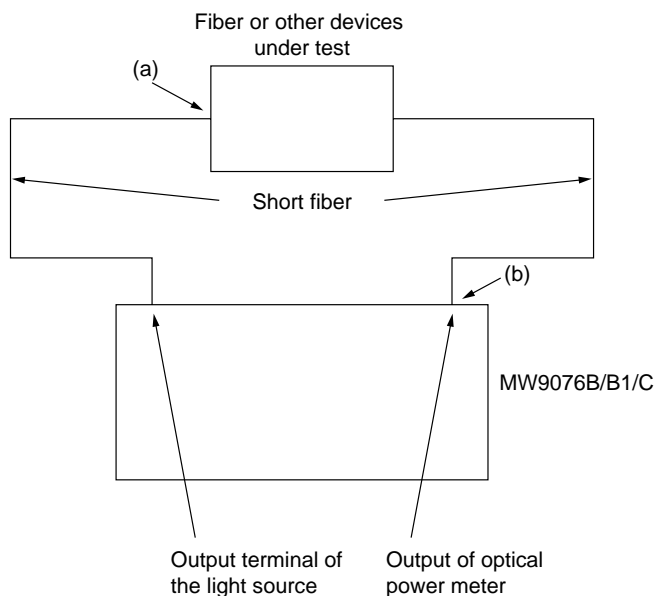

### Measurement procedure

- (1) Close the input end of the optical power meter with the dust cover to eliminate stray light input and to perform offset adjustment of the optical power meter.
- (2) Set the wavelength and the modulation frequency of the light source and the optical power meter. Use the same wavelength and the same modulation frequency for the light source and the optical power meter.
- (3) Measure the optical power level A at Point (a) by connecting Point (a) to the input end of the optical power meter in the Setup (1) configuration.
- (4) Press **F3** (abs → Ref) when the optical power A is displayed to set the optical power A to the reference value. The value of the optical power A is displayed under Ref on the screen after the setting.
- (5) Measure the optical power level B at Point (b) in the Setup (2) configuration. The optical loss (A-B) of the fiber under test is displayed under Loss.

## Section 5 Operation (OLTS Measurement)

---

**Note:**

Be sure to cut off the optical input and perform offset adjustment of the optical power meter, in order to measure correctly.

Unless performing offset adjustment of the optical power meter, the measurement result is not correct.

# Section 6 Operation (CD Measurement)

---

MW9076D/D1 can measure chromatic dispersion (hereafter referred to as CD) of the optical fiber in the Full Auto mode from a single end, in addition to the OTDR function.

6.1	Measurement Principles .....	6-2
6.2	Outline of Chromatic Dispersion Measurement .....	6-4
6.3	Measurement Procedures (Flow) .....	6-5
6.4	Details of Measurement Procedures .....	6-7
6.4.1	From OTDR to CD .....	6-7
6.4.2	Setup .....	6-8
6.4.3	End detection .....	6-11
6.4.4	CD Measurement .....	6-12
6.4.5	CD Calculation .....	6-15
6.4.6	Manual Mode .....	6-18
6.4.7	Saving and printing .....	6-18

# 6.1 Measurement Principles

The following diagram shows the principles of chromatic dispersion measurement by MW9076D/D1.

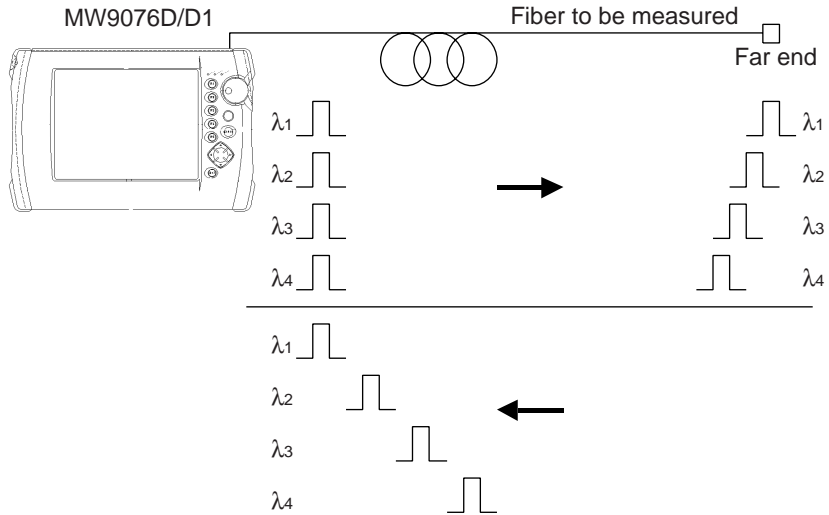

<1> Chromatic dispersion refers to a phenomenon of different optical propagation speeds in the optical fiber caused by different wavelengths. Accordingly, optical pulses with different wavelengths are transmitted along the optical fiber from the OTDR and the differences in arrival time of optical pulses (Fresnel reflection) which return from the far end are measured.

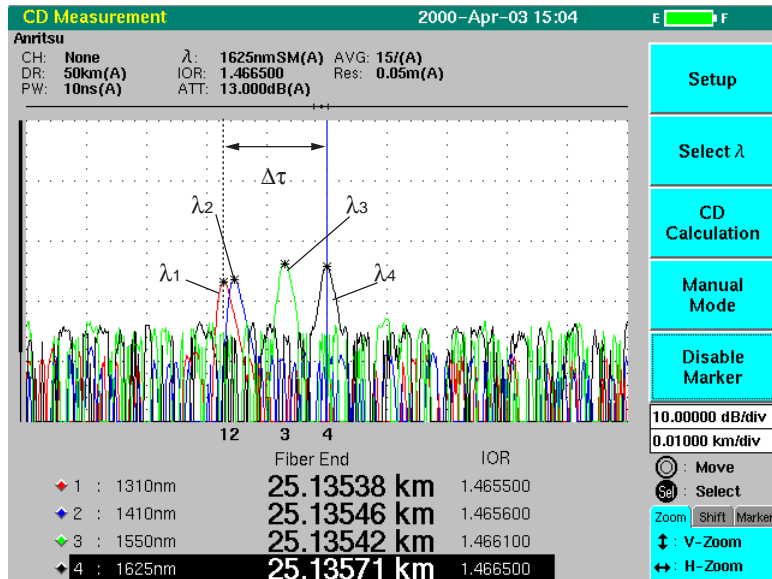

Measured value of Fresnel reflection

<2> Perform fitting using the approximate formula shown below for the measured value obtained in <1>.

**Approximate formula:**

$a + b\lambda^2 + c\lambda^{-2}$  ...Single model fiber

$a\lambda^2 + b\lambda + c$  ...Dispersion-shifted fiber

$a\lambda^4 + b\lambda^2 + c + d\lambda^{-2} + e\lambda^{-4}$  ...Any (5 term Sellmeier)

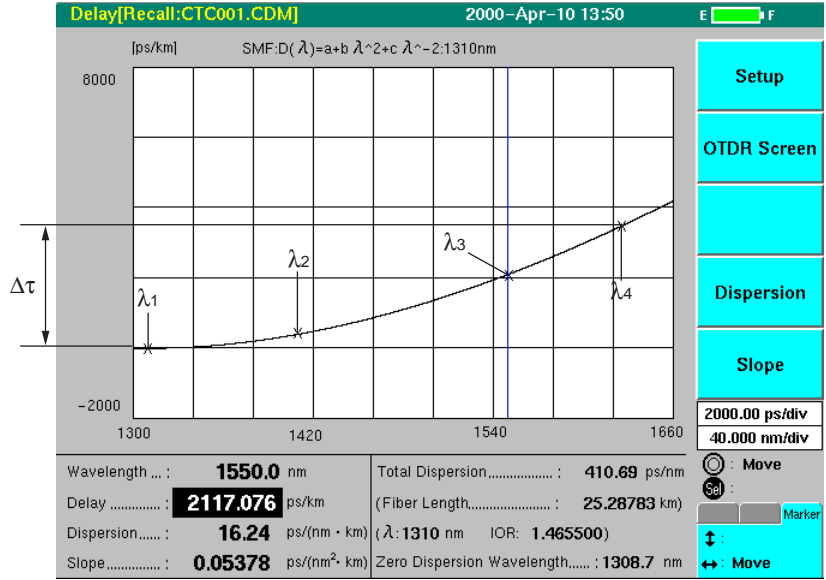

Fitting curve

<3> Differentiating the approximation curve obtained in <2> by the wavelength produces the chromatic dispersion value. Further differentiating the dispersion value by the wavelength produces the dispersion slope value.

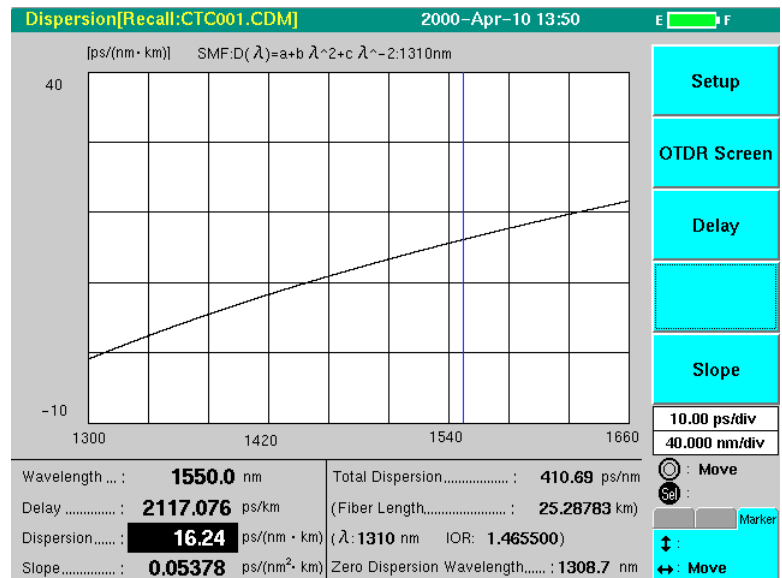

Chromatic Dispersion Value curve

## 6.2 Outline of Chromatic Dispersion Measurement

The chromatic dispersion measurement is performed in the following two steps.

- **Step 1 End detection**

Roughly identifies the position of Fresnel reflection at the far end of the optical fiber for the chromatic dispersion is to be measured. Performs measurement using a single wavelength.

- **Step 2 CD measurement**

Performs precise measurements of the peak position of Fresnel reflection at the far end using four wavelengths based on the position obtained from End detection. Then, it calculates chromatic dispersion, dispersion slope and delay from the measurement results.

### Measurement mode

- **Full Auto mode**

Performs End detection and CD measurement, respectively. This unit automatically sets the distance range, pulse width, attenuator value and other measurement conditions and performs measurements.

- **Auto mode**

Performs End detection and CD measurement, respectively. Operations are performed basically in the same manner as in the Full Auto mode. However, the measurement conditions can partly be set in the way the user chooses.

- **Manual mode**

Performs the CD measurement only. This mode is convenient when planning to measure fibers of almost the same length consecutively. This mode can be selected on the Setup Screen after measurements are performed in the Full Auto mode or Auto mode.



# 6.3 Measurement Procedures (Flow)

User operation is indicated in boxes.  
Internal processing of the equipment is indicated in brackets.

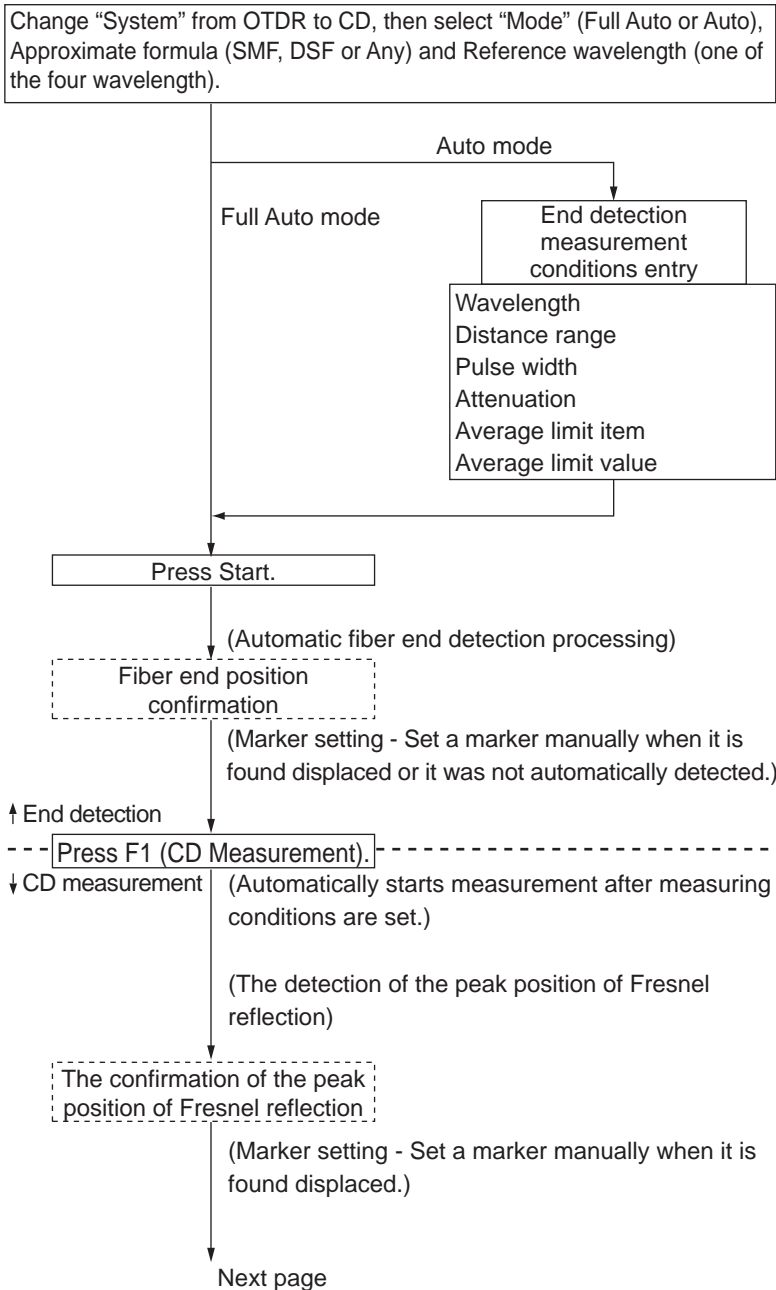

6  
Operation (CD Measurement)

**Section 6 Operation (CD Measurement)**

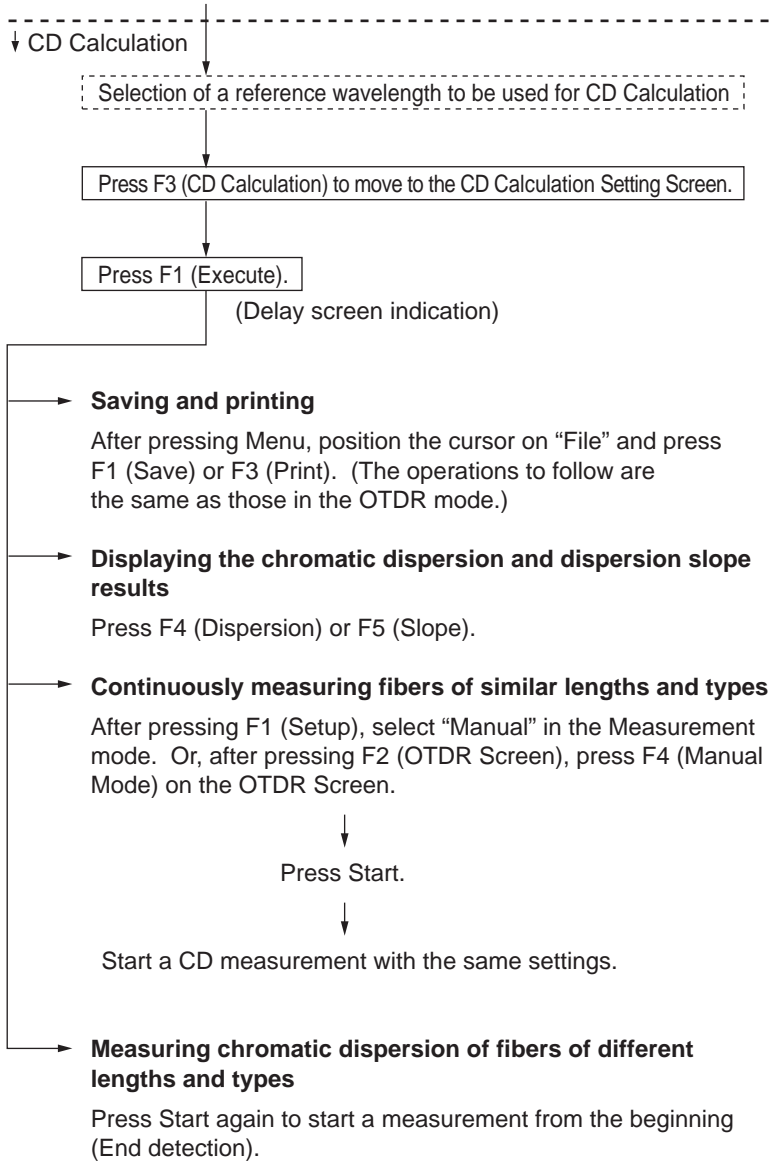

# 6.4 Details of Measurement Procedures

## 6.4.1 From OTDR to CD

Select "System" on the Setup Screen 1 to open a window as shown in the figure below.

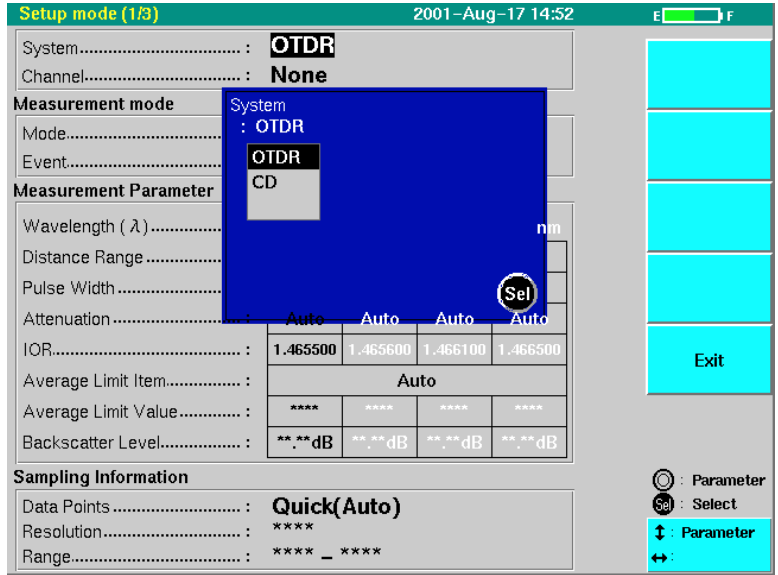

Select CD to move to the chromatic dispersion (CD) measurement. A screen appears as shown in the figure below.

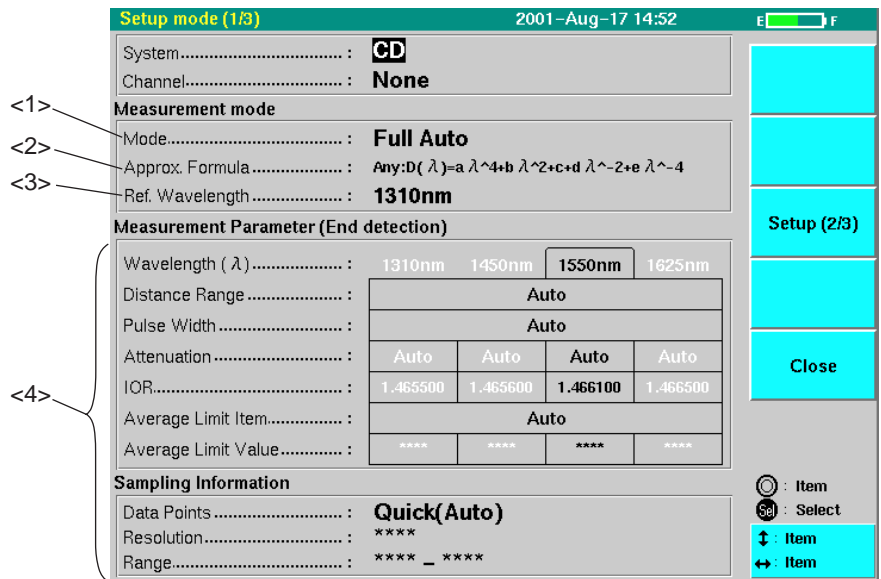

6  
Operation (CD Measurement)

## 6.4.2 Setup

### Setup 1/3 setting

First, select a measurement mode. Three measurement modes are available. Normally, select Full Auto when you are measuring a fiber for the first time. Next, select an approximate formula and reference wavelength. When Auto is selected as the measurement mode, measurement parameters can also be set. See the following section for more information on each item.

### <1> Mode

The following three modes shown below are available.

Only Full Auto or Auto can be selected when you have just moved to a CD measurement. However, note that the Manual mode can also be selected after an End detection or a CD measurement is performed in the Full Auto or Auto mode.

#### Full Auto

Performs End detection and CD measurement, respectively. This unit automatically sets the distance range, pulse width, attenuation value and other measurement conditions and perform measurements.

#### Auto

Performs far end detection and CD measurement, respectively. Operations are performed basically in the same manner as in the Full Auto mode. However, the measurement conditions can partly be set in the manner of user choice.

#### Manual

Performs the CD measurement only. This mode is convenient when planning to measure fibers of almost the same length consecutively. This mode can be selected on the Setup Screen after measurements are performed in the Full Auto mode or Auto mode.

Changing a measurement mode to the Manual mode causes the unit to move to a CD measurement.

<2> **Approx. Formula**

Select an approximate formula to perform delay calculation in CD calculation. An approximate formula can be selected from the three types listed below depending on the type of fiber. Select SMF and DSF when you are using a single mode fiber and a dispersion-shifted fiber, respectively. Five-term Sellmeier (Any) can also be selected as another option.

SMF  $D(\lambda) = a + b\lambda^2 + c\lambda^{-2}$  (Sellmeier)

DSF  $D(\lambda) = a\lambda^2 + b\lambda + c$  (Quadric)

Any  $D(\lambda) = a\lambda^4 + b\lambda^2 + c + d\lambda^{-2} + e\lambda^{-4}$  (Five term Sellmeier)

<3> **Ref. Wavelength**

Select a reference wavelength from the four wavelengths. A reference wavelength here refers to a wavelength which is set as a reference for delay calculation. More specifically, calculation is to be performed in such a way that the delay equals to zero at this wavelength. In addition, the distance to be used for calculation is determined by this wavelength. Normally, select a wavelength where IOR of the fiber is already known.

<4> **Measurement Parameter**

There are two types of measurement parameters: End detection parameters and CD measurement parameters. They switch between themselves depending on the state of measurement. End detection parameters are displayed in this state. They are set in the same manner as those for OTDR. They are set entirely automatically in the Full Auto mode. The table below shows whether each parameter can be selected or not in the Auto mode. ○ means that the item can be selected, while X means that the item cannot be selected.

**When the Measurement mode is in the Auto mode**

Setup Item	Far end detection time
Wavelength	○
Distance range	○
Pulse width	○
Attenuator	○ — if the pulse width is fixed × — if the pulse width is set to Auto
Group index (IOR)	○
Average limit item	○
Average limit value	○ — if the item is “Number” or “time.” × — if the average limit value is set to Auto
Data points	×
Sampling resolution	×

### **Setting on Setup 2/3**

Three items shown below can be set on Setup 2/3.

Active Fiber Check

Connection check

Visible LD

Each function is the same as OTDR setting. See “3.2.2 Setup Screen 2” for more information.

### **Setting on Setup 3/3**

Items to be set on Setup 3/3 are also the same as OTDR setting. See “3.2.3 Setup Screen 3” for more information.

### 6.4.3 End detection

Press **Start** after setting on the Setup screens is completed to start End detection of the fiber to be measured. The measurement takes place by using a single wavelength (normally, the wavelength of 1550 nm). When the measurement ends and the far end are detected, a marker is positioned at the far end section of the fiber and a message prompting you to check the far end is displayed. Check that the far end position has been detected and press **F1** (CD Measurement). This starts the next CD measurement. If the detection of the far end has failed, a message appears prompting you to manually position the marker at the far end section. Accordingly, position the marker at the far end section and press **F1** (CD Measurement).

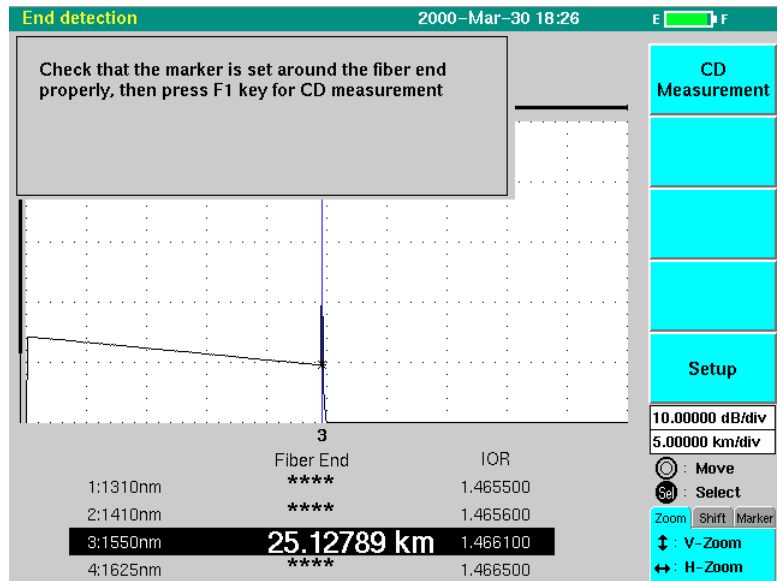

In the Auto mode, pressing **F2** (Select  $\lambda$ ) during a measurement stops the measurement using the wavelength measured and causes the OTDR measurement using the next wavelength to be resumed. Pressing **F2** during a measurement using the wavelength of 1625 nm causes the measurement to be resumed using the wavelength of 1310 nm.

## CAUTION

The OTDR outputs high-power optical pulses. Please disconnect the communication equipments from the optical fibers before measurement in case that the optical sensor breaks.

### 6.4.4 CD Measurement

Press **F1** (CD Measurement) after the completion of End detection to start a CD measurement. The measurement of the fresnel reflection position using four wavelengths conducted from the far end of the fiber features a high sampling resolution and short pulse width. (Normally, sampling resolution of 0.05 m and pulse width of 10 ns). When the measurements of all the wavelengths come to an end, the peak position of fresnel reflection is automatically detected and a marker appears at the peak position. Check that an asterisk marker is located on each Fresnel reflection. If no problems are detected when the marker is checked, press **F3** (CD Calculation) to move to CD Calculation.

Pressing **F2** (Select  $\lambda$ ) during a measurement ends averaging processing at that wavelength and moves to the measurement using the next wavelength. When the measurement of the fourth wavelength comes to an end, the entire measurement is completed.

If the detection of a peak position has failed, a message indicating the wavelength at which the failure occurred is displayed then the distance of the fiber end at that wavelength turns "Off". In addition, if the marker is found dispositioned from the peak position, it can be moved manually. Press **Select** to switch a card to a "Marker" to move the marker by using **<** and **>**.

Enlarge the waveform as shown in the following figure and position the marker at the center position of the pulse waveform.

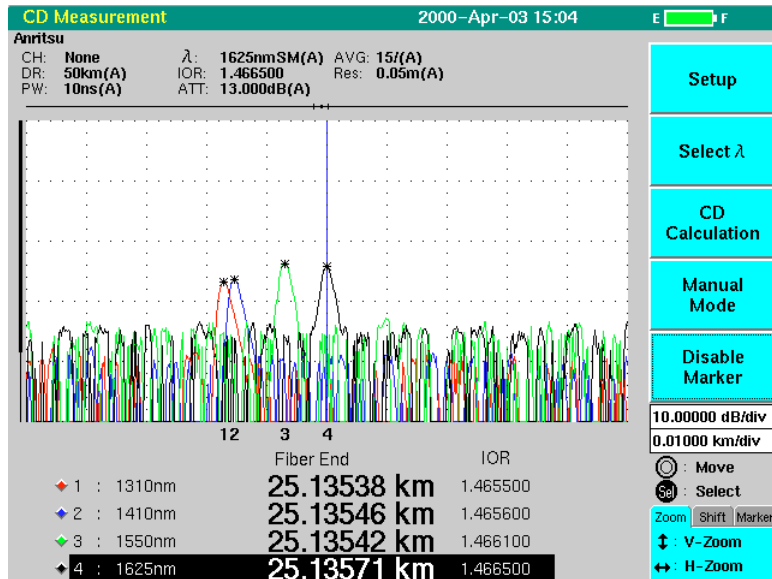
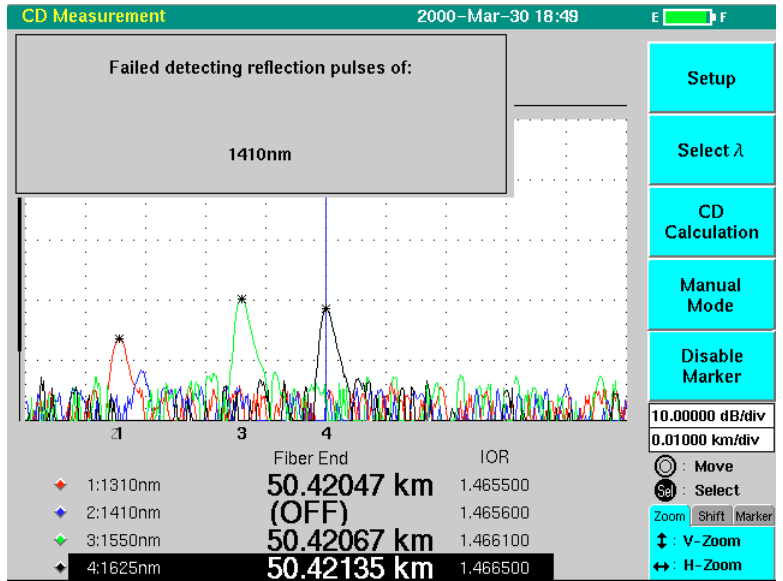

Figure CD Measurement result screen





Comment to be displayed when peak position detection fails



Set position for the fresnel reflection peak  
(When operated manually)

**Detailed explanation of the function keys**

**Setup (F1)**

Moves the screen back to the Setup Screen.

Whether each measurement parameter can be selected or not during the CD measurement is shown below. ○ means that the item can be selected, while × means that the item cannot be selected.

**Auto mode**

Setup Item	CD measurement time
Wavelength	×
Distance range	×
Pulse width	○
Attenuator	○ — if the pulse width is fixed × — if the pulse width is set at Auto
Group index (IOR)	○
Average limit unit	○
Average limit value	○ — if the unit is “frequency” or “time.” × — if the average limit value is set at Auto
Data point count mode	×
Sampling resolution	○

**Manual mode**

Setup Item	CD measurement time
Wavelength	×
Distance range	×
Pulse width	○
Attenuator	○ — if the pulse width is fixed × — if the pulse width is set at Auto
Group index (IOR)	○
Average limit unit	○
Average limit value	○ — if the unit is “frequency” or “time.” × — if the average limit value is set at Auto
Data point count mode	×
Sampling resolution	○

**Select λ (F2)**

Causes the marker located at the peak position of Fresnel reflection of the wavelength which comes to the next wavelength detected to move every time this key is pressed.

**CD Calculation (F3)**

Moves the screen to the delay screen after the confirmation of the approximate equation of delay arithmetic and the reference wavelength.

**Manual Mode (F4)**

Press this key to continuously measure fibers of similar length. Press this key to fix the distance range and the sampling range within the value currently set during the CD measurement. Press **Start** to start a CD measurement.

**Disable Marker (F5)**

Press this key to set marker Off if you do not wish to use the data on the wavelength during the CD Calculation. Press this key again to set the marker On again. When the marker is set Off for three waveforms, movement to CD Calculation is disabled.

Setting the marker Off first and then setting it On again enables the marker to be automatically positioned at the peak position when you have moved the marker from the peak position of fresnel reflection and wish to detect the peak position again.

**6.4.5 CD Calculation**

Performs Calculation (delay, chromatic dispersion and dispersion slope) concerning chromatic dispersion based on the values obtained from the CD measurement to display the results in the form of a graph chart.

Press **F3** (CD Calculation) on the screen on which a CD measurement has been completed to display the screen shown below.

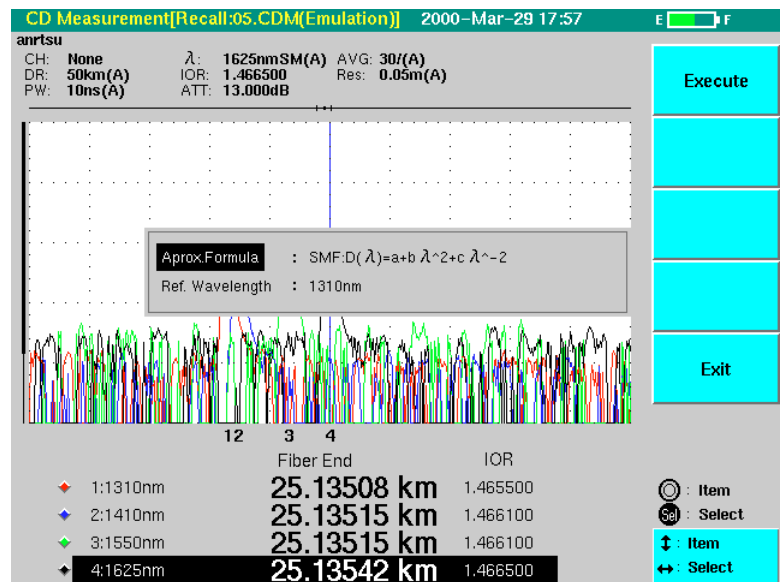
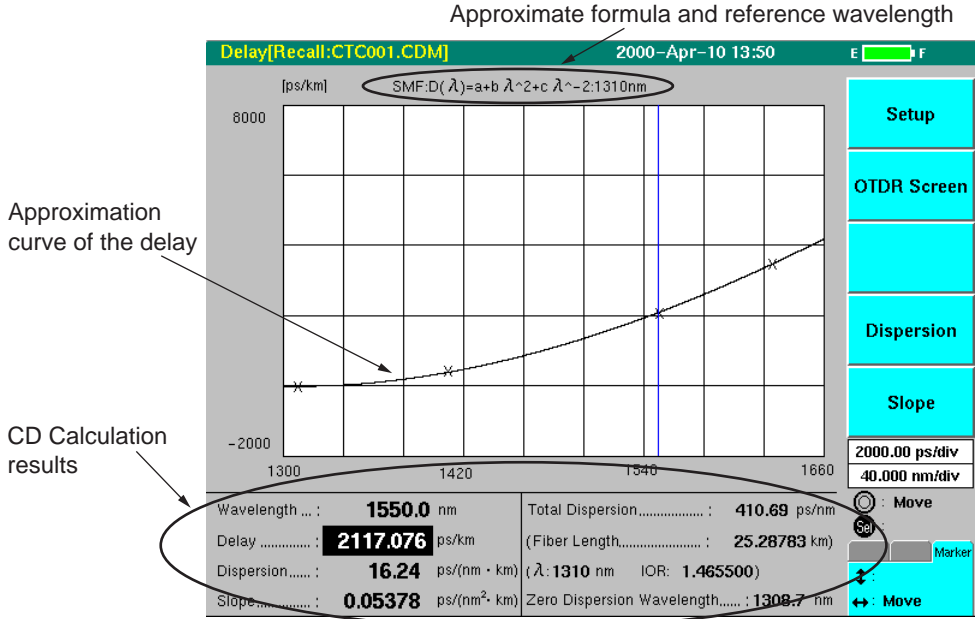

**Figure** Dialog box promoting user confirmation of approximate formula and reference wavelength

**Section 6 Operation (CD Measurement)**

Check the approximate formula and reference wavelength and press **F1** (Execute) if no problems are found. The display screen then appears.

The horizontal scale represents the wavelength on all the screens showing delay, dispersion and slope.



**Figure Example of Delay indication**

Press **<** or **>**, or turn the rotary knob to move the marker. This causes the wavelength, delay, dispersion, slope, and total dispersion values to change depending on the marker position.

Press **F4** (Dispersion) or **F5** (Slope) to view the waveform data of chromatic dispersion or dispersion slope, respectively.

When the marker is set On for two wavelengths, an calculation error may occur. (Three wavelengths for Any of the approximate formula)

The CD calculation results are displayed on all the screens showing the calculation results of the delay, dispersion and slope.

Explanation for each item is given below.

Wavelength: The current marker position (1550.0 nm at the beginning)

Delay: Delay at the wavelength where the marker is currently located.

Dispersion:	The dispersion value at the wavelength where the marker is currently located
Slope:	The dispersion slope at the wavelength where the marker is currently located.
Zero-dispersion wavelength:	The wavelength at which the dispersion obtained from the approximate formula becomes zero.
Total dispersion:	The dispersion value of the entire fiber at the wavelength where the marker is currently located.
Fiber length:	The distance to the far end of the fiber to being measured (reference value)
$\lambda$ :	Reference wavelength
IOR:	The setting value of IOR of reference wavelength

**Detailed explanation of the function keys**

**Setup (F1)**

Moves the screen back to the Setup Screen.

**OTDR Screen (F2)**

Moves the screen back to the CD Measurement Result Screen.

**Dispersion (F4)**

Displays the results of chromatic dispersion calculation in the form of a graphic chart.

**Slope (F5)**

Displays the results of dispersion slope calculation in the form of a graphic chart.

Additionally, the data which include “km” in the unit (delay, dispersion and slope) are operated by using the reference wavelengths.

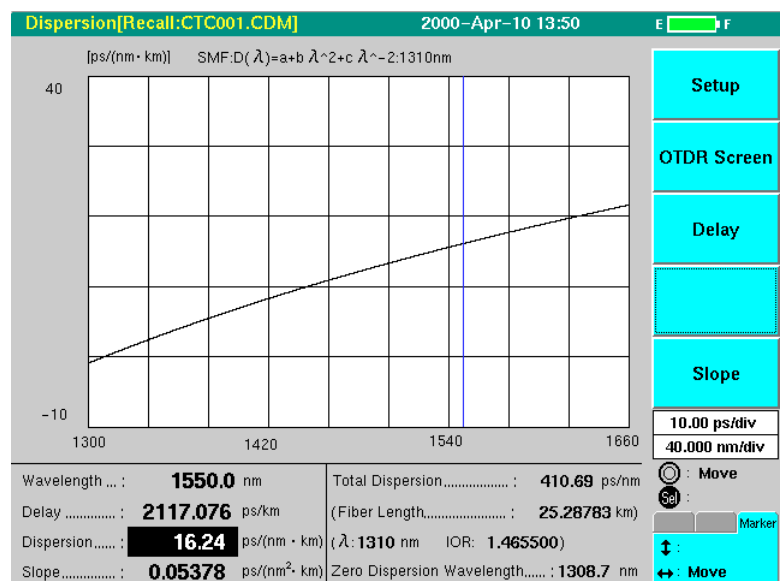
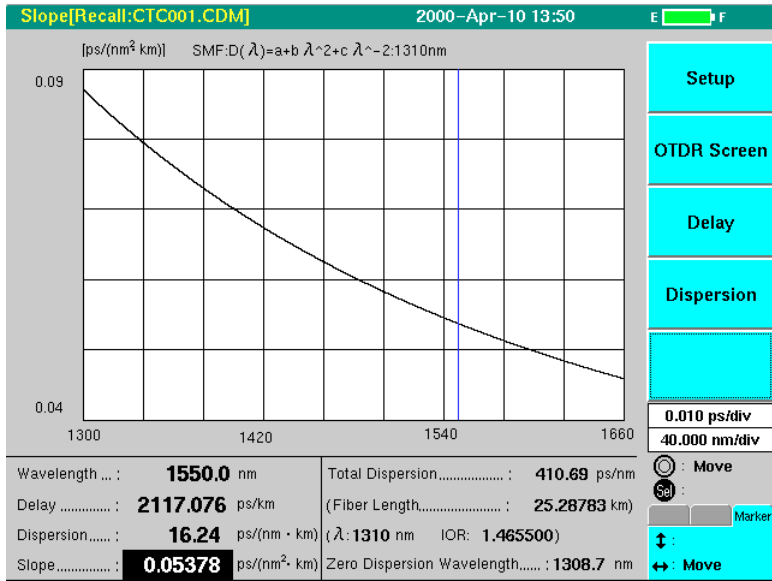

Figure Example of Dispersion indication



Example of Slope indication

### 6.4.6 Manual Mode

#### How to shift to the manual mode

- From the OTDR screen  
 Press **F4** (Manual Mode) on the OTDR screen after the completion of the CD measurement to add the indication of “(Fixed)” alongside the title of “CD Measurement” at the top left of the screen. Press **Start** in this state to start the CD measurement only.

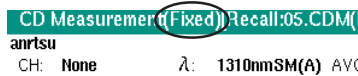

- From the Setup Screen  
 Press **F1** (Setup) after the completion of the measurement in the Full Auto/Auto mode to select Manual for the measurement mode. Then, “(End Detection)” indicated alongside the measurement parameter at the bottom changes to “(CD Measurement)”.

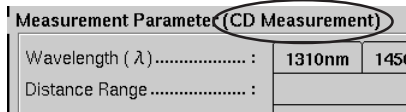

Press **Start** here to start from the CD measurement.

### 6.4.7 Saving and printing

See “Section 7 Operating the functions other than measurements” for more information on saving, reading and printing the results of CD measurements and CD calculation.

# Section 7 Operating the Functions Other Than Measurements

---

This section explains the frequently used operations other than measurements such as printing and data saving.

 in this section indicates a panel key.

7.1	Print .....	7-2
	7.1.1 Printing .....	7-2
	7.1.2 Continuous Printing .....	7-6
7.2	File Operation .....	7-8
	7.2.1 Save .....	7-8
	7.2.2 Recall .....	7-15
	7.2.3 Delete .....	7-19
	7.2.4 Initialize (Format) .....	7-22
	7.2.5 Copy .....	7-23
7.3	Auto Increment Function .....	7-25

# 7.1 Print

## 7.1.1 Printing

This section explains the printing operation using a printer connected to the parallel interface of the OTDR.

This explanation is based on the assumption that the printer is connected and has been specified.

For the printer connection, refer to “Section 2.8.4 Connecting a printer.”

For the specification of the printer, refer to “Section 3.3.2 Setting the printer.”

See “Appendix G List of Recommended Printers” for more information on the types of printers available.

The OTDR can print the wavelength data and measurement results, measurement results only, or the settings on the Setup screen. In addition, the reference waveform can be printed in the waveform comparison mode. The following printing example shows the printout of the waveform data and measurement results. Refer “3.4.3 Print the Settings” to see the print of the Setup screen.

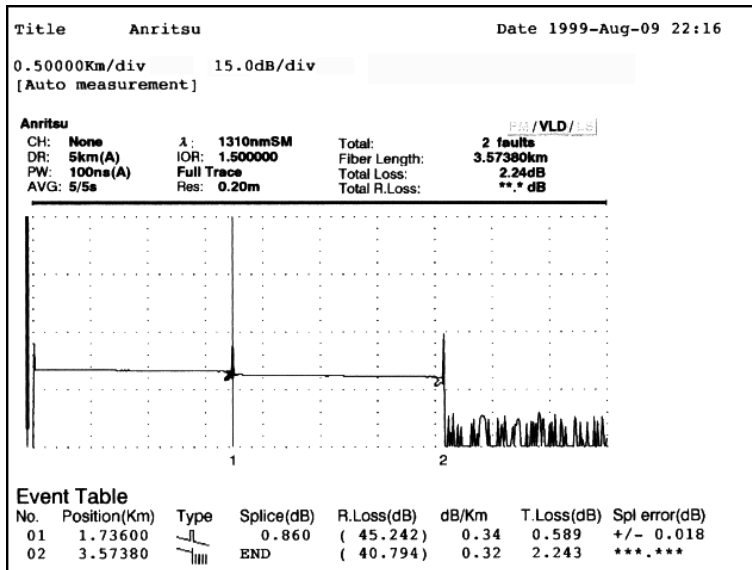

**Note:**

If an error occurs during printing, turn off the power of the printer, eliminate the trouble, and then turn on the power of the printer again.

Click the F2 (Delete) key on the printer setting screen to clear the internal buffer if printing continues because the data to be printed is not cleared from the equipment buffer.



The printing procedure is described below.

Press **Menu** after the measurement has been completed, the following menu window opens.

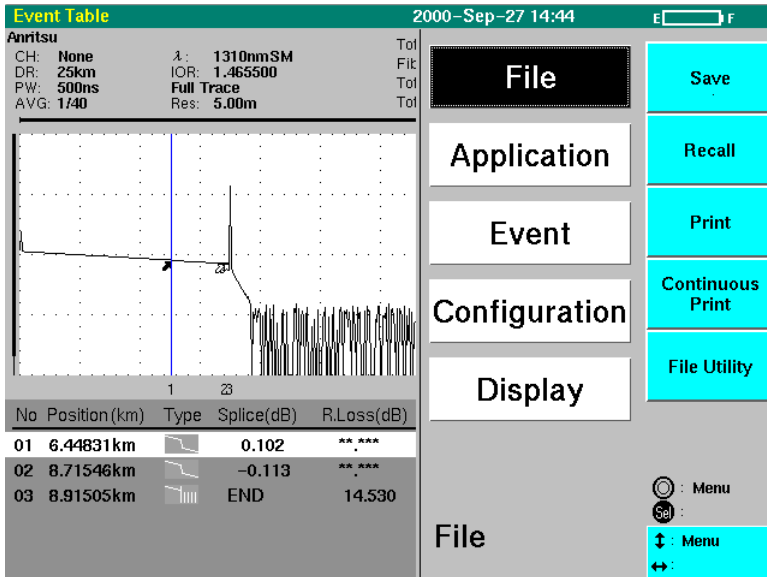

When **F3** (Print) is pressed, the print setting screen is displayed. (See the figure below.)

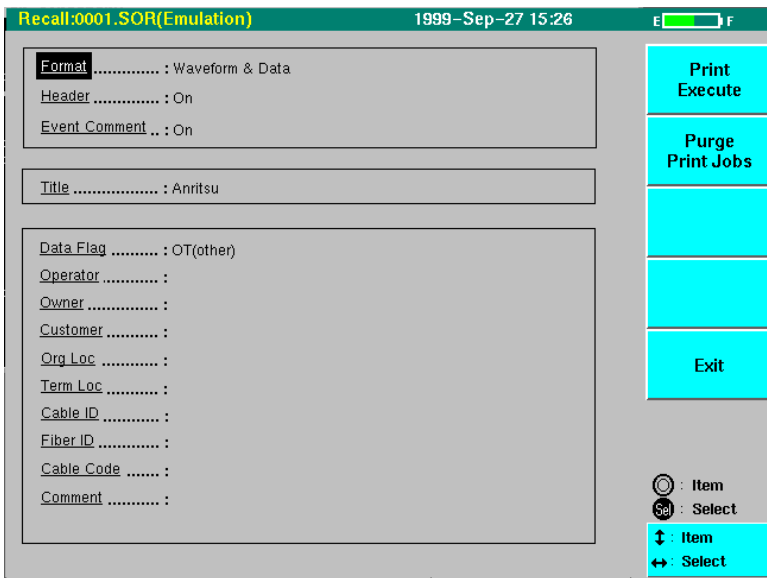

## Section 7 Operating the Functions Other Than Measurements

Place the cursor on the desired item with the  $\uparrow$  and  $\downarrow$  keys or the rotary knob, and then enter the selected item with **Select** or the  $\leftarrow$  and  $\rightarrow$  keys.

The following items can be set on the print setting screen.

### Format (Print Format)

Select the data to be printed.

When Format is selected, the following window is opened.

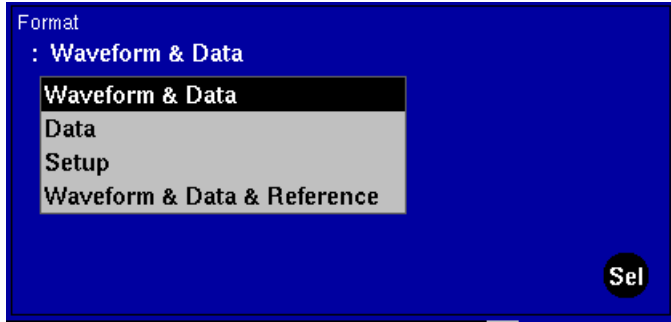

Place the cursor on the format to be set using the  $\uparrow$  and  $\downarrow$  keys.

#### **Waveform & Data**

Both waveform data and measurement result are printed.

#### **Data**

Only the measurement result is printed.

#### **Setup**

The settings on the Setup screen are printed.

Waveform, data and reference

#### **Waveform, Data and Reference Waveform**

In the waveform comparison mode for MW9076, the current waveform and reference waveform data are printed. When this item is specified at normal OTDR or CD measuring, the same contents as when “Waveform and Data” is set are printed.

After the cursor is positioned on the desired option, press **Select** to enter the option.

**Header**  
**(Header On/Off)**

Set whether to print the entered header.

When Header is selected, the following window is opened.



Place the cursor on the option to be set using the  $\wedge$  and  $\vee$  keys.

**On**

The entered header is printed.

**Off**

The entered header is not printed.

After the cursor is put on the desired option, press **Select** to enter the option.

**Event Comment**  
**(Event Comment On/Off)**

Set whether to print the entered event comment.

Set in the same way as Header.

**On**

The entered event comment is printed.

**Off**

The entered event comment is not printed.

**Title**

The title entered here is printed.

Refer “3.2.3 Setup screen 3” how to input the title.

**Header**

The items on the left are the contents of the header. Enter the characters for the required items. Refer “3.2.3 Setup screen 3” how to input the each item.

**Data Flag**  
**Operator**  
**Owner**  
**Customer**  
**Org Location**  
**Term Location**  
**Cable ID**  
**Fiber ID**  
**Cable Code**  
**Comment**

The characters described here are printed only when Header is set to ON. The characters cannot be printed simply by inputting them.

Press **F1** (Print Execute) after the setting and entry of each item are completed. Printing is started from the connected printer.

**Note:**

1. The key input will not be accepted, when the printing starts and while the message that shows the printing is in progress is displayed.
2. Full View Window cannot be printed.

### 7.1.2 Continuous Printing

Outputs waveform data sequentially to the printer. Printing set up for each file is not required.

For Continuous printing, file reading and printing are automatically repeated. The current waveform display is therefore lost. Execute "File write" to save a file beforehand, if required.

In the OTDR mode for MW9076, press **Menu** on the measurement completion screen to open the menu window. Selecting "File" using **^** and **v** displays "Continuous Print" in the F4 function key label. Press **F4** (Continuous Print) to display the file selection screen shown below. Select the file to be printed. File selection is the same as in copying and deletion. See section 7.2.3 "Delete" for details.

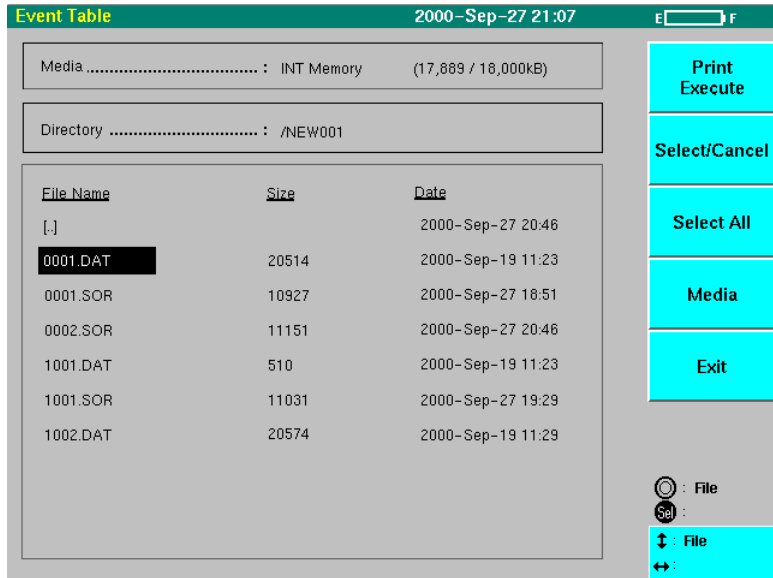

After selecting the file to be printed, press **F1** (Print Execute) to set the print details. Setting printing contents is the same as ordinal printing. See section 7.1.1 "Printing" for details.

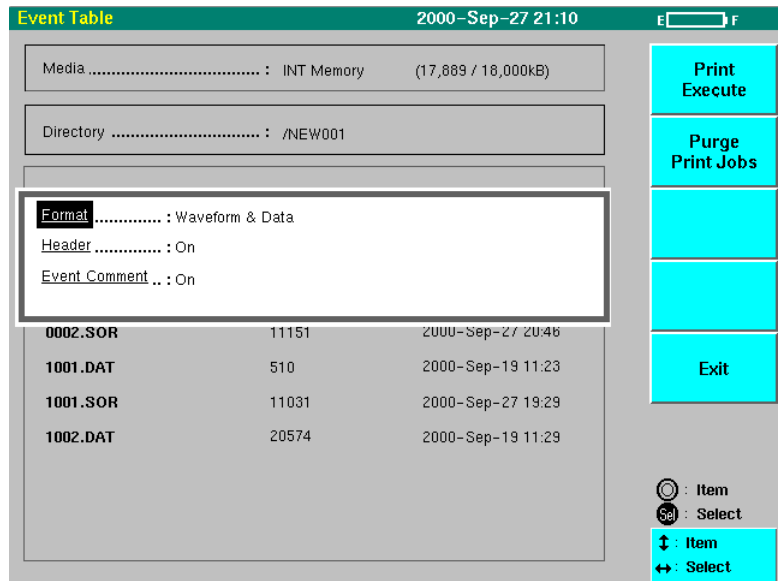

After setting print details, press **F1** (Print Execute) again to start sequential printing.

- \* Some files saved in the analysis format do not have waveform data. Such files are not printed.
- \* CD measurement files are not printed.

## 7.2 File Operation

The OTDR can save the wavelength data to a file, recall the wavelength data from a file, delete a file, initialize the media, and copy a file.

File operation can be performed for internal memory, memory cards, and floppy disks.

**Note:**

Once a file is deleted, the file cannot be restored. Sufficient care should be exercised in file operation.

### 7.2.1 Save

This section explains the method of saving a file to the specified media.

The following file is opened when **Menu** is pressed in the measurement end screen.

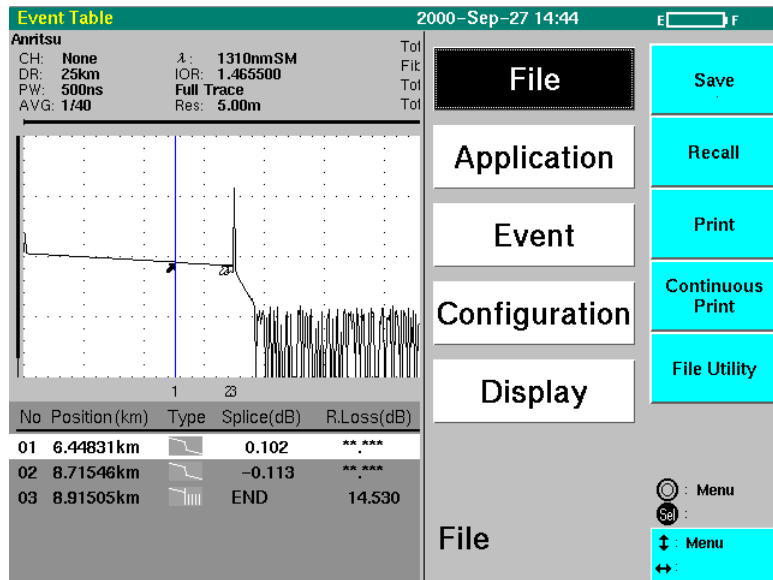

Select File with the **Λ** and **∇** keys or the rotary knob.

When **F1** (Save) is pressed, the screen shown on the next page is displayed.

Manual measurement 1999-Aug-04 21:42 E F

File Type ..... : Standard  
File Compress... : Off

Media ..... : INT Memory  
Directory ..... : /NEW001  
File Name ..... : 1550nm : 1001.SOR  
Increment Step : +1

Title ..... : Anritsu

Data Flag ..... : BC(as\_built)  
Operator ..... :  
Owner ..... :  
Customer ..... :  
Org Loc ..... :  
Term Loc ..... :  
Cable ID ..... :  
Fiber ID ..... :  
Cable Code ..... :  
Comment ..... :

Save Execute

Exit

⊙ : Item  
Sel : Select  
↓ : Item  
↔ : Select

Place the cursor on the desired item with the  $\wedge$  and  $\vee$  keys or the rotary knob, and then select the item with **Select** or the  $\leftarrow$  and  $\rightarrow$  keys.

It is necessary to set the following items on the print setting screen for saving the data.

## File Type

The following window is opened when File Type is selected.

However, note that CD, CSV is displayed in the CD, OLTS mode and selection is disabled in this case.

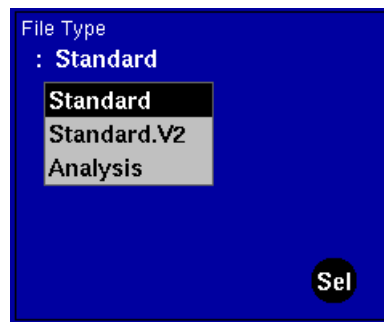

Place the cursor on the file type with the  $\wedge$  and  $\vee$  keys.

### Standard

Data can be saved in a format that conforms with to Bellcore GR-196-CORE (Issue 1, Revision 1, December 1997). The extension is .SOR.

### Standard.V2

Data can be saved in a format that conforms with to Telcordia Technologies SR-4731 (Issue 1, February 2000). The extension is “.SOR”.

### Analysis

This is the format for analyzing the waveform, and it is the special format of this equipment. The extension is .dat.

**CD**

This type is for chromatic dispersion measurement. The extension is .cdm.

**CSV**

This format is for the OLTS measurement Loss Table. The extension is .csv.

After the cursor is placed on the desired format, enter the format by pressing

**Select**.

**CAUTION** 

**The files saved in the standard format cannot always record all the information displayed at OTDR.**

**The value of dB/km after reading out a file may be different from the value before saving the file as an error in IOR conversion may occur because of the difference in recording forms.**

**File Compression**

When file compression is turned ON, the waveform data can be compressed and stored to reduce file size.

Compressed and stored file names are displayed in the file list as follows:

filename.zip (← compressed file name)

+filename.dat (← uncompressed file name)

Data are read in the same manner when the file compression is OFF.

**Media**

The following window is displayed when Media is selected.

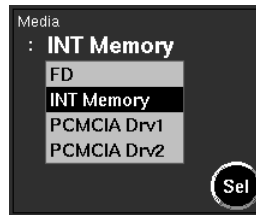

Place the cursor on the desired media with the **^** and **v** keys.

**FD**

Data is saved in a floppy disk.

**INT Memory**

Data is saved in internal memory.

**PCMCIA Drv1**

Data is saved in Drive 1 of the memory card.

**PCMCIA Drv2**

Data is saved in Drive 2 of the memory card.

After the cursor is placed on the desired media, enter the format by pressing

**Select**.

The number displayed in the right of Media is the memory capacity (remaining capacity/all capacity).

The capacity is displayed in unit of 1k byte, and the capacity less than 1k byte is displayed as 0.



**Number of files able to be saved**

The following tables indicate the number of waveforms that can be recorded. Please note that the file capacity varies to a certain extent by the version of the built-in program or the display area.

**OTDR**

Media	Standard format	Analysis format
FDD	123	67
PC-ATA card (32 MB)	2700	1520
PC-ATA card (256 MB)	16000	10600
Built-in memory (18 MB)	1560	860

Number of data points: 5001

**CD**

Media	CD format
FDD	85
PC-ATA card (32 MB)	1800
PC-ATA card (256 MB)	10600
Built-in memory (18 MB)	1060

When measuring a 50 km, SM fiber, in the Full Auto mode

**Directory**

When Directory is selected, the following directory selection screen is displayed.

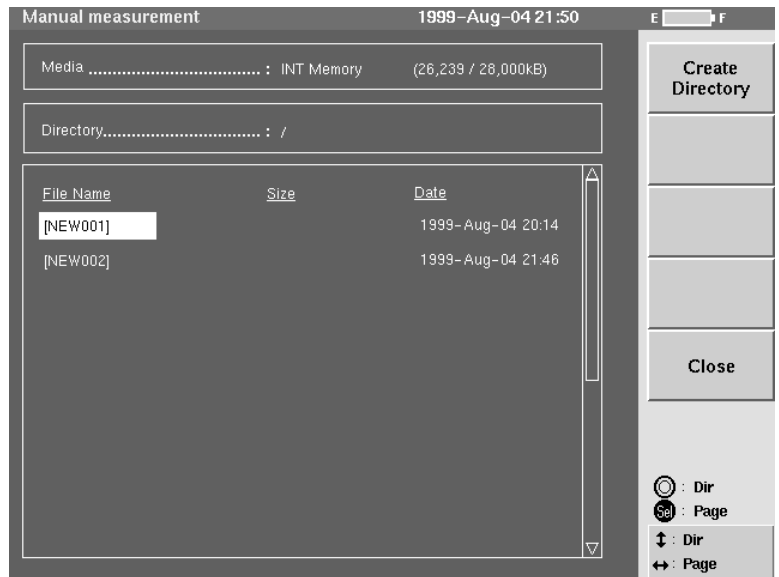

**Section 7 Operating the Functions Other Than Measurements**

Select the directory to save data with the  $\wedge$  and  $\vee$  keys. When the  $\leftarrow$ ,  $\rightarrow$  or **Select** keys are pressed, the selected directory is displayed. At this time the display at Directory is changed to the selected directory name.

To return to its parent directory, place the cursor on [..], and press the  $\leftarrow$ ,  $\rightarrow$  or **Select** keys.

A new directory can be created on the directory selection screen. Follow the procedure below for creating a new directory.

- (1) Press **F1** (Create Directory).
- (2) The following directory name setting window is opened.

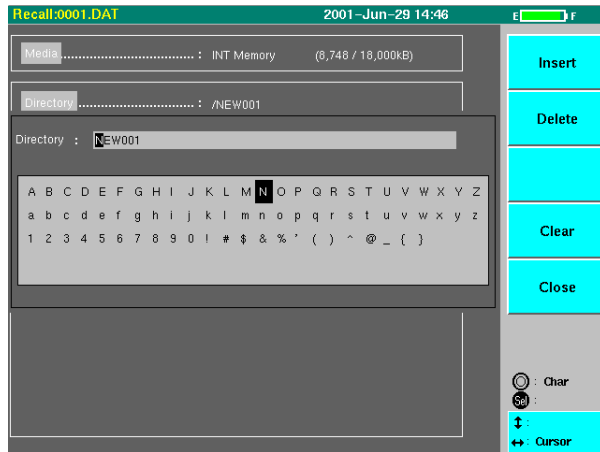

- (3) Using the  $\leftarrow$  and  $\rightarrow$  keys, move the cursor to the position in which the characters are to be entered.
- (4) Select the characters to be entered with the rotary knob. The characters selected with the rotary knob are displayed at the cursor. Up to eight characters can be entered as the directory name.
- (5) Press **F5** (Close) after the directory name has been entered.
- (6) A new directory is created.



**Note:**

A directory is always created once the directory name setting window is selected. Do not select Create Directory if you do not want to create a directory.

**File name**

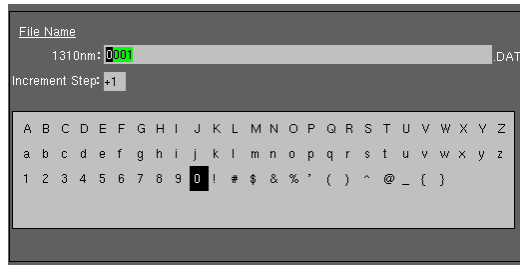



The following window is opened when File Name is selected.



Using the  and  keys, move the cursor to the position in which the characters are to be entered.

Select the characters to be entered with the rotary knob. File name can be expressed up to 32 characters.

The function keys that can be used in the file name input window are explained below.

Insert	
Delete	
Increment	
Clear	
Close	

**Insert (F1)**

Inserts a character before the cursor.

**Delete (F2)**

Deletes the character under the cursor.

**Increment (F3)**

Sets the character under the cursor to auto increment.  
See “7.3 Auto Increment Function” for more information.

**Clear (F4)**

Clear the file name.

**Close (F5)**

Closes the file name setting window.

Click the  (Save Execute) key after the settings and input of all the items have been completed.

This starts the saving of the file.



File Access Mark

## CAUTION

---

1. The File Access Mark is displayed on the top right-hand side of the screen while the file is being saved. Do not remove the media while the File Access Mark is displayed. The data may be destroyed or the media may be damaged.
  2. The system may take about 30 seconds to store a large data file in a floppy disk.
  3. When multiple wavelengths are specified, the measured waveform cannot be saved in the standard / standard.V2 format without trace data for all of the wavelengths.
  4. Only capital letters can be used for the filename. A file whose filename is in lowercase letters is overwritten if a file is saved with the same name in capital letters.
  5. When a file is copied, a file whose name is in lowercase letters is overwritten as mentioned in item 4 above.
-

## 7.2.2 Recall

This section explains the method of recalling the file saved in the specified media.

The following file is opened when **Menu** is pressed in the measurement end screen.

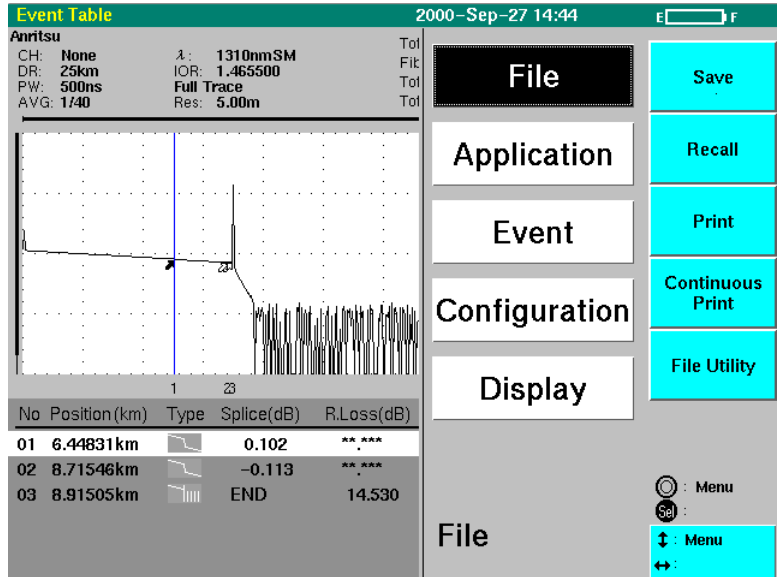

Select File with the **^** and **v** keys or the rotary knob.

The following screen is displayed when **F2** (Recall) is pressed.

Only the names of files enabled to be read in the OTDR, OLTS or CD mode are displayed. (The extension is SOR and DAT for OTDR, CSV for OLTS, and CD1 to 4 or CDM for CD.)

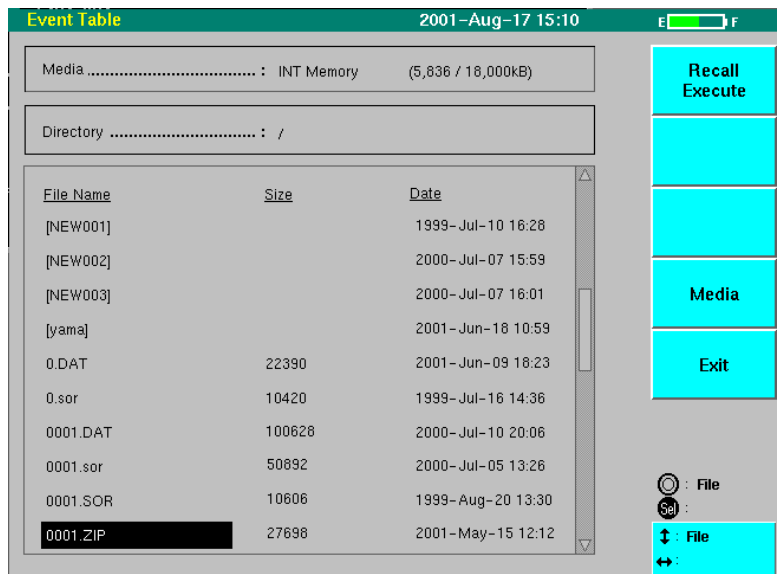

## Section 7 Operating the Functions Other Than Measurements

The number displayed in the right of Media is the capacity (remaining capacity/all capacity) of the objective Media.

The capacity is displayed in unit of 1k byte, and the capacity less than 1k byte is displayed as 0.

The function key labels shown on the next page are displayed when **F4** (Media) is pressed. Select the media in which the file to be recalled is stored with the function keys.

FD	F1
INT Memory	F2
PCMCIA Drv1	F3
PCMCIA Drv2	F4
Exit	F5

### FD (F1)

The floppy disk is selected.

### INT Memory (F2)

The internal memory is selected.

### PCMCIA Drv1 (F3)

Drive 1 (at the slot on the front side) is selected.

### PCMCIA Drv2 (F4)

Drive 2 (at the slot on the rear side) is selected.

### Exit (F5)

Media selection is suspended.

Function key selection is not necessary to recall a media set in advance (one that is displayed on the screen).

When media is selected, the file names or directories stored in the media are displayed.

Put the cursor on the file name to be recalled with the **^** and **v** keys or the rotary knob.

After the cursor is placed on the desired file name, press **F1** (Recall Execute). The recalling operation starts.

After moving the cursor to a directory using the **^** and **v** keys or the rotary knob, it is possible to enter the directory by pressing the **<** and **>** keys or **Select**.

Click the **F1** (Recall Execute) key after the settings and input of all the items have been completed.

The file recall is started.

When a file is read or selected (used for copy or deletion), the cursor automatically moves either one line up or down in the direction of the movement immediately before.

In addition, when the horizontal direction **<** and **>** of the cross key are pressed at a place other than the directory name on the file selection screen, the page is scrolled up and down a half page (five lines) size, respectively.

**CAUTION** 

1. The file access mark is displayed at the upper right of the screen while reading a file. Do not remove the media while the File Access Mark is displayed. The data may be destroyed or the media may be damaged.
2. The system may take about 30 seconds to recall a large data file in a floppy disk.
3. The stored files or the measurement conditions of the MW9076 can be recalled or changed, respectively, if the name of the OTDR to be recalled matches with that of the stored OTDR. However, if the names do not match, the OTDR can be recalled but the status is converted to the emulation mode which cannot be changed using the measurement conditions in the Setup (1/3) screen. To cancel the emulation mode, click the F1 (Emulation Off) key on the Setup screen. The optimum measurement conditions for the equipment are set again. However, the displayed waveform is deleted.

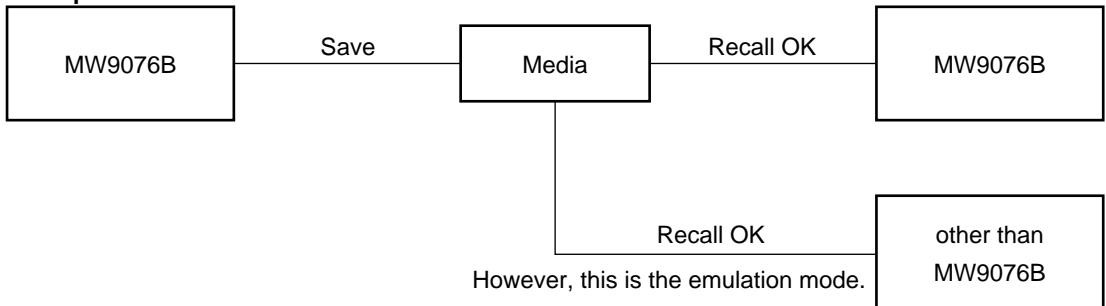
**Example:**

## CAUTION

4. Analysis and standard format files of firmware version 3.0 and higher can be recalled, but the status changes to the emulation mode. Waveforms in print format cannot be recalled. In addition, file with firmware versions earlier than V3.0 may not work properly. Files saved in the MX3607B with version earlier than V3.0 may not work properly.

**Example:**

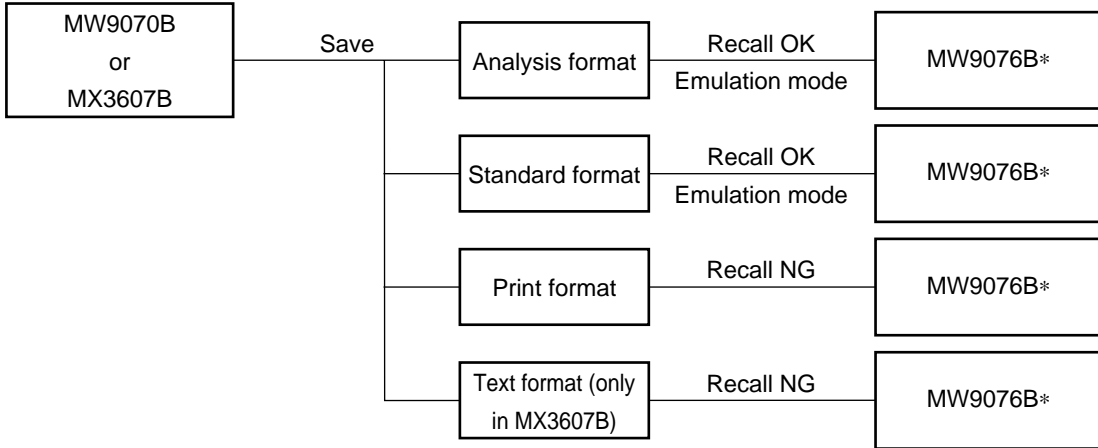

5. Among the recalled files, only the analysis format and Standard format files measured using MW9076 Series and the analysis format files measured using MW9070B can be used the event-point detection with re-auto search. Standard format files which are measured using OTDRs produced by other companies cannot be used for event-point detection even if auto search is performed.
6. The files saved in the standard format cannot always record all the information displayed at OTDR.  
 The value of dB/km after reading out a file may be different from the value before saving the file as an error in IOR conversion may occur because of the difference in recording forms.  
 The amount of reflection is not recorded in a standard format file recorded in other than MW9076 Series. Therefore, the amount of reflection is displayed as **\*\*\*.\*\*\*** when the file is read out.



## CAUTION

7. The extension of the chromatic dispersion measurement data file of software version less than 1.3, is anyone of .CD1 to .CD4. It is .CDM for the software version 2.0 or more.  
The software version 2.0 or more can read the files with the extension .CD1 to .CD4. When the file with the extension .CD1 to .CD4 is saved by the software version 2.0 or more, the saved file extension is changed to .CDM.
8. A data file saved in the OLTS mode is in a text format. It can be edited with PC but cannot be read by this device once it is edited.

### 7.2.3 Delete

This section explains the method of deleting the file saved in the specified media. The following window is opened when **Menu** is pressed on the measurement end screen.

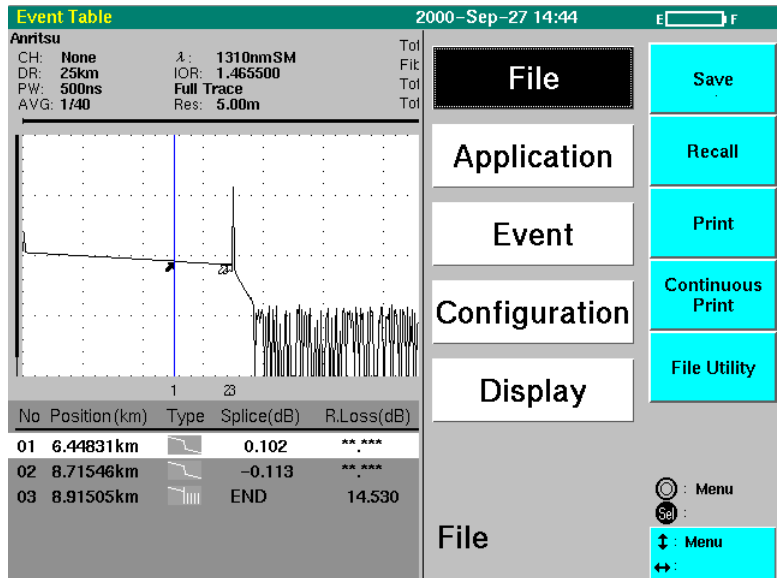

Copy	F1
Delete	F2
Create Directory	F3
Format	F4
Exit	F5

Select File with the **Up** and **Down** keys or the rotary knob.

The following function key labels are displayed when **F5** (File Utility) is pressed.

The deletion screen is displayed when **F2** is pressed.

See the next page for the deletion screen.

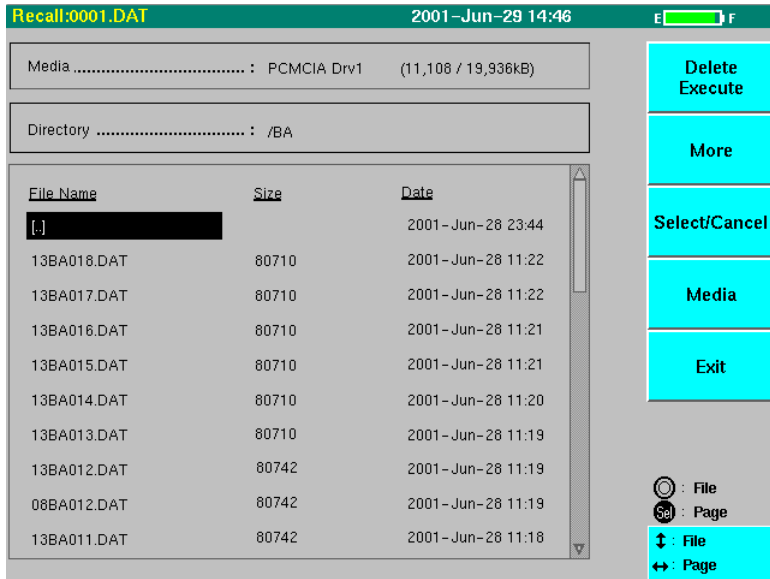

Use the  $\uparrow$  and  $\downarrow$  keys or the rotary knob to place the cursor on the file name you want to delete.

When you select the file name by pressing  $F3$  (Select/Cancel), the selected file name is displayed in bold type. When you want to cancel the selection, place the cursor on it and press  $F3$  (Select/Cancel).

When you press  $F1$  (Delete Execute) after the selection, a confirmation message is displayed. Press  $F1$  (Yes) again to start the deletion. To stop the deletion halfway, press  $F5$  (Delete Stop).

## CAUTION

**The deleted file cannot be recovered. Be careful when deleting a file or a directory.**  
**When a directory is selected, all files in the directory are deleted.**

### Function key contents

#### Delete Execute (F1)

After selecting the file to be deleted, press  $F1$  (Delete Execute).

#### More (F2)

By pressing  $F2$  (More), the following function keys are displayed:

#### Sort (F1)

$F1$  (Sort) can be pressed to arrange the displayed file names in the specified item order. Items that can be used to sort are File Name, Size, Date and their ascending and descending orders.

**Back (F2)**

Pressing **F2** (Back) resumes the Delete function key.

**Select All (F3)**

Pressing **F3** (Select All) selects all the displayed files.

**Media (F4)**

After pressing **F4** (Media), change the media to one that stores files to delete.

**Exit (F5)**

The deletion is stopped.

### 7.2.4 Initialize (Format)

This section explains the method of initializing (formatting) the specified media so that it can be used in the OTDR.

First, select File Utility by pressing **Menu**. Refer to “Section 7.2.3 Delete” for the method of setting File Utility.

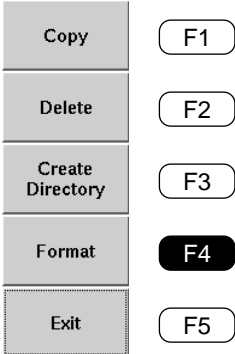

The function key labels shown on the left are displayed when File Utility is selected.

The format screen is displayed when **F4** (Format) is pressed in this state. The format screen is shown below.

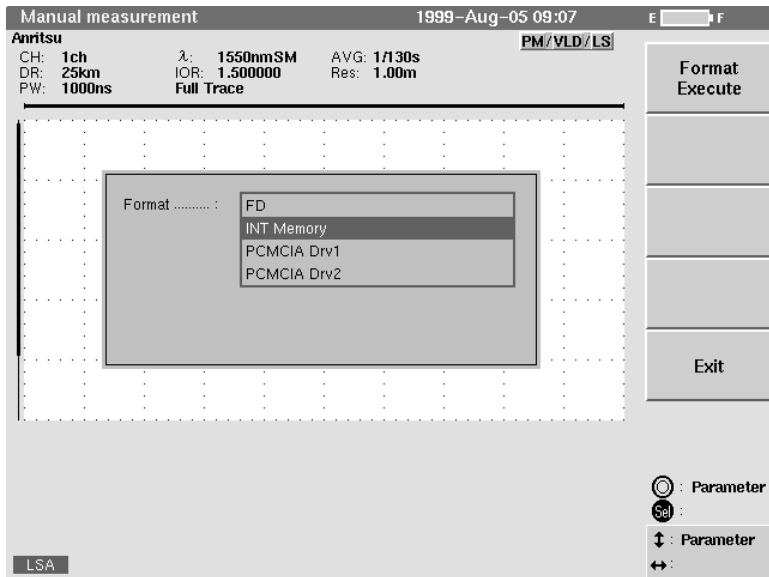

Place the cursor on the media to be initialized with the **^** and **v** keys or the rotary knob.

Initialization is started when **F1** (Format Execute) is pressed.

### CAUTION

When initialization is performed, all the stored files are deleted and the deleted files cannot be restored. Take sufficient care in initializing the media.

## 7.2.5 Copy

The method to copy the specified file is explained.

Select [F5] (File Utility) from **Menu**. For the utility selection method, see "7.2.3 Delete".

When File Utility is selected, function key labels shown on the left are displayed.

Press **F1** (Copy) to display the following copy screen:

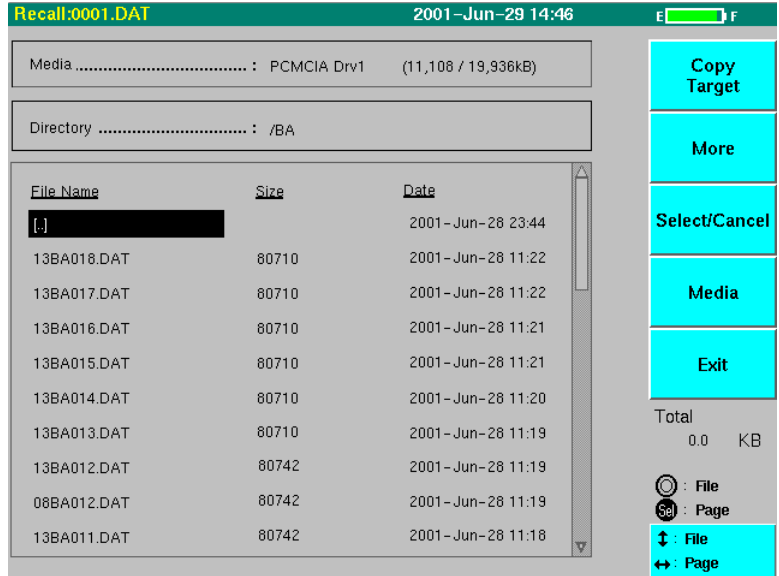
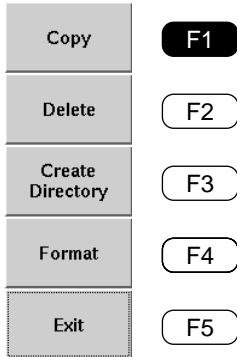

Specify the file to be copied on this screen.

Use the **▲** and **▼** keys or the rotary knob to place the cursor on the file or the directory to be copied.

When you select it by pressing **F2** (Select/Cancel), the selected file name is displayed in bold type. When you want to cancel the selection, place the cursor there again and press **F2** (Select/Cancel). The total size of selected files is displayed under the function key. When you specified a directory, the directory content is not included in the total size.

**Section 7 Operating the Functions Other Than Measurements**

Continue on to select the copy target.

Pressing **F1** (Copy Target) determines the copy source file and the displayed screen color becomes darker than that of the previous copy screen.

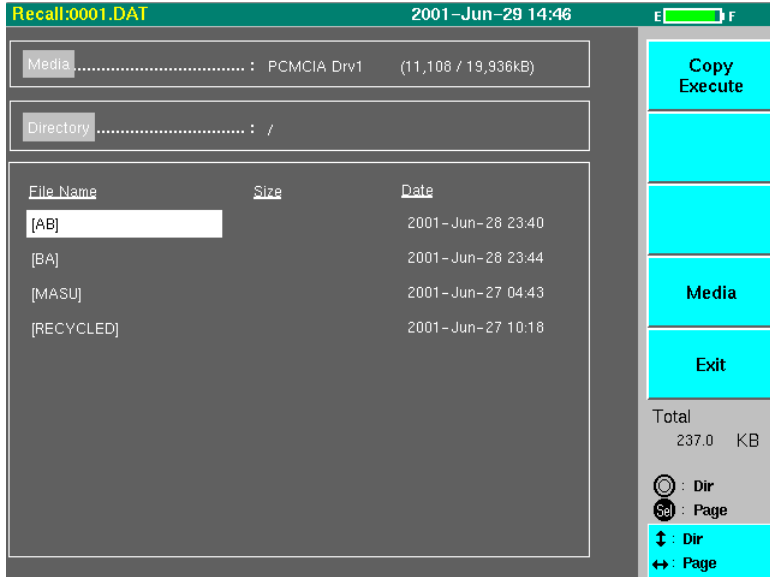

Select the media of copy target by using **F4** (Media) and select the directory by using the **^**, **v**, **<** and **>** keys.

Press **F1** (Copy Execute) to display the confirmation message. Press **F1** (Yes) again to start the copy.

To stop the copy halfway, press **F5** (Copy Stop).

When there is a file with the same name at the copy target, the message is displayed that asks whether you want to overwrite it. Select either **F1** (Yes), **F2** (No), **F3** (Overwrite All), or **F5** (Copy Stop).

For an explanation of **F2** (More) of function keys, see "7.2.3 Delete".

## 7.3 Auto Increment Function

As shown below, each time a waveform is saved, this function automatically increments the number by 1. This function is useful for repeated measurements and data saving such as the measurement on a multi-core fiber.

The auto increment can be set from the file name input window or title input window.

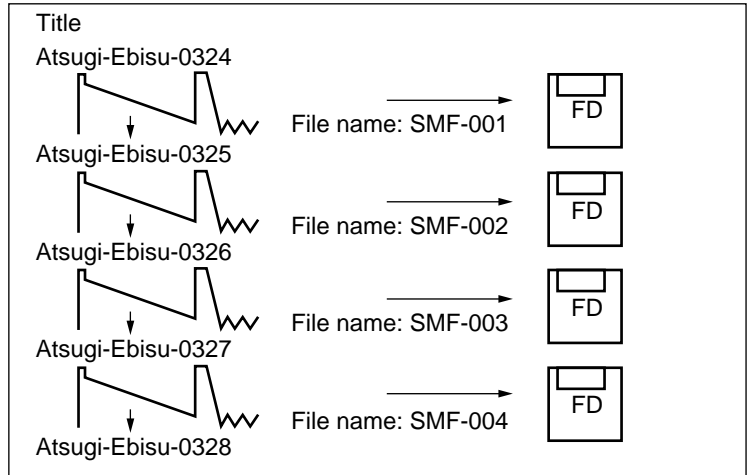

Follow the procedure below to set the digits of auto increment.

Display the title or file name input window for inputting the alphanumeric characters.

In this input window, position the cursor on the numeric characters to be auto-incremented.

### Title input window

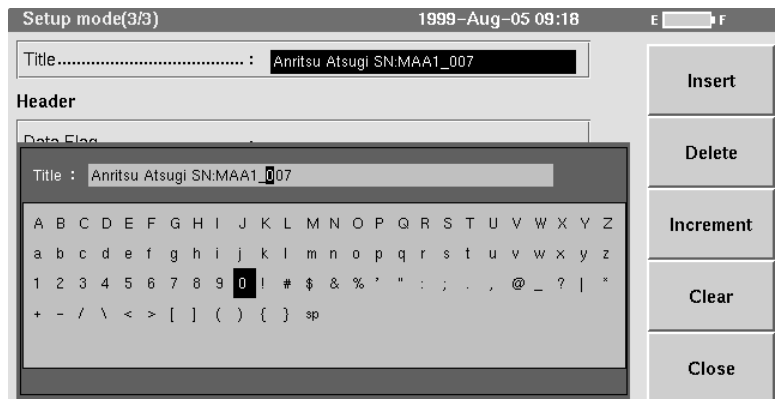

Move the cursor on the numeric characters to be auto-incremented.

When **F3** (Increment) is pressed in this state, the background of the numeric characters changes to green. Auto-increment is set at the colored position.

**Section 7 Operating the Functions Other Than Measurements**

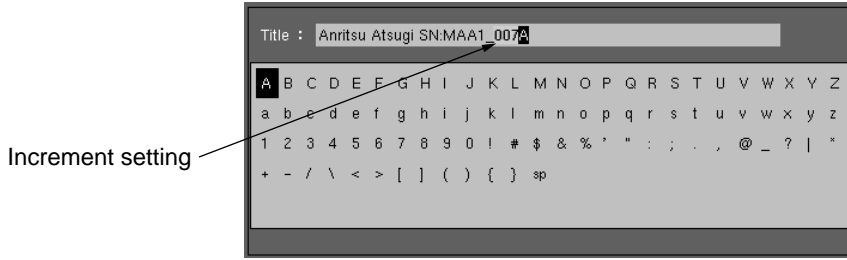

In the above example, the three numeric characters “007” are incremented.

When the cursor is placed on the numeric characters for which auto-increment is set and **F3** is pressed, the auto-increment setting is canceled.

**File name input window**

Auto-increment can be set in the same way as the title input window. Only the displays are shown below.

Before the setting



After the setting





Only numeric characters can be set using the auto-increment function. Up to four numeric characters can be set.

When the increment step is 1, the numbers are incremented as shown below.

1 digit:	8 →	9 →	0
2 digits:	98 →	99 →	00
3 digits:	998 →	999 →	000
4 digits:	9998 →	9999 →	0000



**Setting the increment step**

The number of increment steps for the auto-increment function can be set.

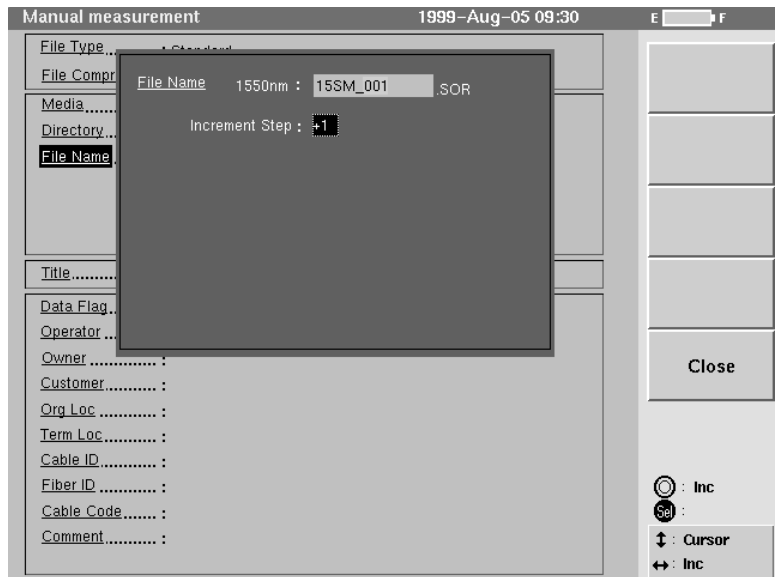

Set the number of steps in accordance with the procedure below.

Open the file name input window. Refer to “Section 7.2.1 Save” for the method of opening the file name input window.



Press  .

The cursor is moved to Increment Step.

Set the number of increment steps with the  and  keys. The value can be set between +10 and -10.

The number is not incremented but decremented when a negative value is set. In the case of decrement, the number decrements only down to zero.



# Section 8 Performance Test and Calibration

This section explains how to check the performance of the OTDR and how to calibrate the measured values.

Contact Anritsu Corporation or your nearest service representative if the performance test described in this section reveals that the system does not conform to specifications.

Provide the following data in advance when requesting repairs.

- (1) Model name, and instrument serial number affixed at the bottom of the machine.
- (2) Failure details
- (3) Name and telephone number of the person in charge whom Anritsu can contact for the detail of the failure or report the completion of repair.

8.1	Performance Test .....	8-2
8.1.1	Wavelength .....	8-8
8.1.2	Pulse width .....	8-9
8.1.3	Dynamic range (one-way back-scattered light dynamic range test) ....	8-10
8.1.4	Horizontal axis accuracy .....	8-11
8.1.5	Vertical axis accuracy .....	8-12
8.1.6	Optical power level and wavelength of visible LD .....	8-13
8.1.7	Optical output level and wavelength of the light source .....	8-14
8.1.8	Measurement range and accuracy of the power meter (options 02 and 03) .....	8-15
8.1.9	Chromatic dispersion value (MW9076D/D1) .....	8-17
8.1.10	Insertion loss of the optical channel selector (MU960001A/2A) ....	8-18
8.2	Calibration .....	8-19
8.3	Performance Test Result Record Form .....	8-20

## WARNING

**NEVER look directly into the optical output connector of the OTDR or into the end of an optical cable connected to the OTDR as the laser light can injure your eyes.**

**Procedures other than those specified herein may result in hazardous radiation exposure.**

## 8.1 Performance Test

The following ten items should be tested to check the performance of the OTDR. (Items 6 and 8 can be tested only when option 01, 02, or 03 is installed.) Item 7 can be tested when MW9076B/C is used.

Item 9 will be tested when MW9076D/D1 is installed. Item 10 will be tested when MU960001A/2A is installed.

- (1) Wavelength
- (2) Pulse width
- (3) Dynamic range
- (4) Horizontal axis accuracy
- (5) Vertical axis accuracy
- (6) Optical power output and wavelength of the visible LD (option 01)
- (7) Optical output level and wavelength of the light source
- (8) Measurement range and accuracy of the power meter (option 02 or 03)
- (9) Wavelength deviation value
- (10) Insertion loss for optical channel selector

Clean the optical connector before performing the test. The test procedure described here assumes that the power switch is turned on and the power lamp is lit. (The description in Section 8.1.1 assumes that the power is turned off.)

### Standard values of test items

The following standard values are guaranteed at a temperature of  $25 \pm 5$  °C.

#### 1. When the MW9076B OTDR main unit is installed

Item	Standard value										Remarks
Center wavelength	1310/1550 $\pm$ 25 nm										Pulse width: 1 $\mu$ s
Pulse width (ns)	10	20	50	100	500	1000	2000	4000	10000	20000	
Dynamic range (dB)	8.9/ 6.9	10.9/ 8.9	12.9/ 10.9	14.4/ 12.4	22.4/ 20.4	24.4/ 22.4	25.9/ 23.9	29.9/ 27.9	37.4/ 35.4	39.9/ 37.9	
Horizontal axis accuracy	$\pm 1$ m $\pm 3 \times$ measured distance $\times 10^{-5} \pm$ marker resolution										
Vertical axis accuracy (linearity)	$\pm 0.05$ dB/dB or $\pm 0.1$ dB (whichever is greater)										
Light source Function											
Optical output power	$-3 \pm 1.5$ dBm										CW
Center wavelength	1310/1550 $\pm$ 25 nm										CW
Spectral width	5/10 nm or less										CW

## 2. When the MW9076B1 OTDR main unit is installed

Item	Standard value										Remarks
Center wavelength	1310/1550 ± 25 nm										Pulse width: 1 μs
Pulse width (ns)	10	20	50	100	500	1000	2000	4000	10000	20000	
Dynamic range (dB)	8.9/ 6.9	10.9/ 8.9	12.9/ 10.9	14.4/ 12.4	22.4/ 20.4	24.4/ 22.4	25.9/ 23.9	29.9/ 27.9	33.9/ 31.9	35.4/ 33.4	
Horizontal axis accuracy	±1 m ± 3 × measured distance × 10 <sup>-5</sup> ± marker resolution										
Vertical axis accuracy (linearity)	±0.05 dB/dB or ±0.1 dB (whichever is greater)										

## 3. When the MW9076C OTDR main unit is installed

Item	Standard value										Remarks
Center wavelength	1310/1550 /1625 ± 25 nm										Pulse width: 1 μs
Pulse width (ns)	10	20	50	100	500	1000	2000	4000	10000	20000	
Dynamic range (dB)	8.9/ 6.9/ 4.4	10.9/ 8.9/ 6.4	12.9/ 10.9/ 8.4	14.4/ 12.4/ 9.9	22.4/ 20.4/ 17.9	24.4/ 22.4/ 19.9	25.9/ 23.9/ 21.4	29.9/ 27.9/ 25.4	36.4/ 34.4/ 31.9	38.9/ 36.9/ 34.4	
Horizontal axis accuracy	±0.1 m ± 3 × measured distance × 10 <sup>-5</sup> ± marker resolution										
Vertical axis accuracy (linearity)	±0.05 dB/dB or ±0.1 dB (whichever is greater)										
Light source Function											
Optical output power	-3 ± 1.5 dBm										CW
Center wavelength	1310/1550/1625 ± 25 nm										CW
Spectral width	5/10/10 nm or less										CW

## Section 8 Performance Test and Calibration

### 4. When the MW9076D OTDR main unit is installed

Item	Standard value										Remarks
Center wavelength	1310/1410 /1550/1625 ± 3 nm Spectrum width ≤1 nm										Pulse width: 1 μs
Pulse width (ns)	10	20	50	100	500	1000	2000	4000	10000	20000	
Dynamic range (dB)	—	3.9/ 2.9/	5.9/ 4.9/ —	7.4/ 6.4/ 5.4/ 2.9	15.4/ 14.4/ 13.4/ 10.9	17.4/ 16.4/ 15.4/ 12.9	18.9/ 17.9/ 16.9/ 14.4	22.9/ 21.9/ 20.9/ 18.4	29.4/ 28.4/ 27.4/ 24.9	31.9/ 30.9/ 29.9/ 27.4	
Horizontal axis accuracy	±0.1 m ± 3 × measured distance × 10 <sup>-5</sup> ± marker resolution										
Vertical axis accuracy (linearity)	±0.05 dB/dB or ±0.1 dB (whichever is greater)										
Chromatic Dispersion measurement Function Dispersion Repeatability	±0.05 ps/(nm·km) (Typical value)										Wavelength: 1.55 μm Fiber: 25 km

### 5. When MW9076D1 OTDR main unit is installed

Item	Standard value										Remarks
Center wavelength	1310/1450 /1550/1625 ± 3 nm Spectrum width ≤1 nm										Pulse width: 1 μs
Pulse width (ns)	10	20	50	100	500	1000	2000	4000	10000	20000	
Dynamic range (dB)	—	3.9/ 2.9/ —	5.9/ 4.9/ 3.9/ —	7.4/ 6.4/ 5.4/ 2.9	15.4/ 14.4/ 13.4/ 10.9	17.4/ 16.4/ 15.4/ 12.9	18.9/ 17.9/ 16.9/ 14.4	22.9/ 21.9/ 20.9/ 18.4	29.4/ 28.4/ 27.4/ 24.9	31.9/ 30.9/ 29.9/ 27.4	
Horizontal axis accuracy	±0.1 m ± 3 × measured distance × 10 <sup>-5</sup> ± marker resolution										
Vertical axis accuracy (linearity)	±0.05 dB/dB or ±0.1 dB (whichever is greater)										
Chromatic Dispersion measurement Function Dispersion Repeatability	± 0.05 ps/(nm·km) (Typical value)										Wavelength: 1.55 μm Fiber: 25 km

## 6. When MW9076J OTDR is installed

Item	Standard value				Remarks
Center wavelength	850 ± 30 nm				Pulse width: 100 ns
Pulse width (ns)	10	20	50	100	
Dynamic range (dB)	11.3	13.3	15.3	18.4	
Horizontal axis accuracy	$\pm 1 \text{ m} \pm 3 \times \text{measured distance} \times 10^{-5} \pm \text{marker resolution}$				
Vertical axis accuracy (linearity)	$\pm 0.05 \text{ dB/dB}$ or $\pm 0.1 \text{ dB}$ (whichever is greater)				

## 7. When MW9076K OTDR main unit is installed

Item	Standard value						Remarks
Center wavelength	850/1300 ± 30 nm						Pulse width: 100 ns
Pulse width (ns)	10	20	50	100	500	1000	
Dynamic range (dB)	11.3/ 10.3	13.3/ 12.3	15.3/ 14.3	18.4/ 15.8	-/ 19.3	-/ 22.4	
Horizontal axis accuracy	$\pm 1 \text{ m} \pm 3 \times \text{measured distance} \times 10^{-5} \pm \text{marker resolution}$						
Vertical axis accuracy (linearity)	$\pm 0.05 \text{ dB/dB}$ or $\pm 0.1 \text{ dB}$ (whichever is greater)						

## 8. When the visible LD option is installed (MW9076B/B1/C/D/D1/J/K-01)

Item	Standard value	Remarks
Center wavelength	635 ± 15 nm	
Optical output power	-3 ± 1.5 dBm	

## 9. When the optical power meter option is installed (MW9076B/B1/C-02, -03)

Item	Standard value	Remarks
Measurement range	Option 02 +3 dBm to -70 dBm (CW light) +0 dBm to -75 dBm (Modulation light) Option 03 +23 dBm to -50 dBm (CW light) +20 dBm to -55 dBm (Modulation light)	
Accuracy	Option 02 ±5 % (-10 dBm, 1.31/1.55 μm CW light) Option 03 ±5 % (-10 dBm, 1.31/1.55 μm CW light)	

## Section 8 Performance Test and Calibration

### 10. When an optical channel selector (MU960001A/2A) is installed

Item	Model	Standard value	Remarks
Insertion loss	MU960001A	2.5 dB or less	1.31/1.55 $\mu\text{m}$ , CW
	MU960002A	4.5 dB or less	

### Measuring Instruments and Optical Fibers Required in the Performance Test (for SM unit)

Test item	Wavelength	Pulse Width	Dynamic Range	Hor. Axis Accuracy	V. Axis Accuracy	Light Source Output Level	Power Meter		Chromatic Dispersion	Insertion loss
							Measurement Range	Accuracy		
Measuring Instrument and Cable	OTDR Output, Light Source Output, Option 01					Light Source Output, Option 01				
Optical Spectrum Analyzer MS9710B Wavelength: 0.6 to 1.75 $\mu\text{m}$ Level: -65 to +20 dBm	○									
Optical Variable Attenuator MN9610B Wavelength: 1.31/1.55 $\mu\text{m}$ Attenuation: 60 dB or more		○								
Optical Variable Attenuator MN9002A Wavelength: 1.31/1.55 $\mu\text{m}$ Attenuation: 60 dB or more					○		○	○		
Waveform Monitor MP9655A Wavelength: 1.2 to 1.6 $\mu\text{m}$ Rise/Fall: 500 ps or less		○								
Oscilloscope DC 200 MHz		○								
SM Optical Fiber (25 km) SM Optical Fiber (75 km)			○						○ *1	
SM Optical Fiber (2 km) SM Optical Fiber (2 m)				○						○
Optical Power Meter ML9001A+MA9001B+ MA9411A Wavelength: 0.38 to 1.15 $\mu\text{m}$ Level: -70 to 7 dBm						○	○			○
LD Light Source MG9001A + MG0930C Wavelength: 1.31/1.55 $\mu\text{m}$							○			○
Standard Optical Power Meter ML9050A								○		
Function Generator Frequency: 100 Hz to 5 kHz Output Level: 16 Vp-p or more Waveform: Square Wave							○			

\*1 Use an optical fiber of known Chromatic Dispersion value (1.3  $\mu\text{m}$ , 0-dispersion wavelength).



### Measuring Instruments and Optical Fibers Required in the Performance Test (for GI unit)

Test item	Wavelength	Dynamic Range	Hor. Axis Accuracy	V. Axis Accuracy	Light Source Output Level
Measuring Instrument and Cable	OTDR Output, Option 01				Option 01
Optical Spectrum Analyzer MS9710B Wavelength: 0.6 to 1.75 $\mu\text{m}$ Level: -65 to +20 dBm	○				
GI Optical Fiber (62.5/125 $\mu\text{m}$ ) (8 km)		○		○	
GI Optical Fiber (62.5/125 $\mu\text{m}$ ) (4 km)		○	○		
GI Optical Fiber (62.5/125 $\mu\text{m}$ ) (2 m)	○				
SM Optical Fiber (2 m)					○
Optical Power Meter ML9001A+MA9001B+MA9411A Wavelength: 0.38 to 1.15 $\mu\text{m}$ Level: -70 to 7 dBm					○
Programable Optical Attenuator MN938A Wavelength: 0.85 to 1.3 $\mu\text{m}$ Attenuation: 60 dB or more				○	

## 8.1.1 Wavelength

This test measures the center wavelength of the laser output light and checks that it meets the specification.

### Setup

Connect the units as shown in the figure below.

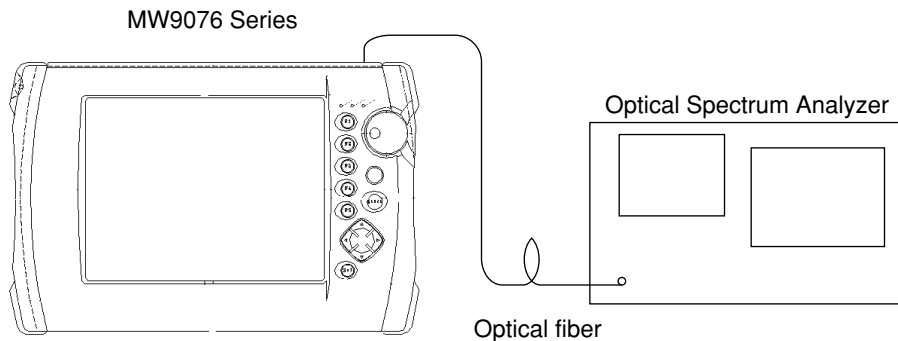

### Test procedure

- (1) On the Setup screen, set the wavelength at which a measurement is to be performed.
- (2) For the SM unit, set the distance range to 50 km and the pulse width to 1000 ns while setting the distance range to 10 km and pulse width to 100 ns for the GI unit, and then close the setup screen.
- (3) Press **Menu** and then **F5** (Selftest) under Configuration to open the Selftest screen, and then press **F2** (NILE Mode On) for continuously outputting optical pulses. The laser output can be stopped by pressing **F3** (NILE Mode Off).
- (4) Input the laser light into the optical spectrum analyzer and adjust its measurement level and wavelength resolution.
- (5) Select the RMS method on the optical spectrum analyzer.
- (6) Check that the measurement result is within standard values.
- (7) To perform measurements at other wavelengths, press **F3** (NILE Mode Off) to return to Setup Screen 1, change the wavelength, and repeat the procedure from step 3 onwards. To stop the measurement, press **F3** (NILE Mode Off) to stop the continuous output of optical pulses.

### 8.1.2 Pulse width

This test measures the pulse width of the outputted laser and checks that it conforms to the specifications.

#### Setup

Connect the units as shown in the figure below.

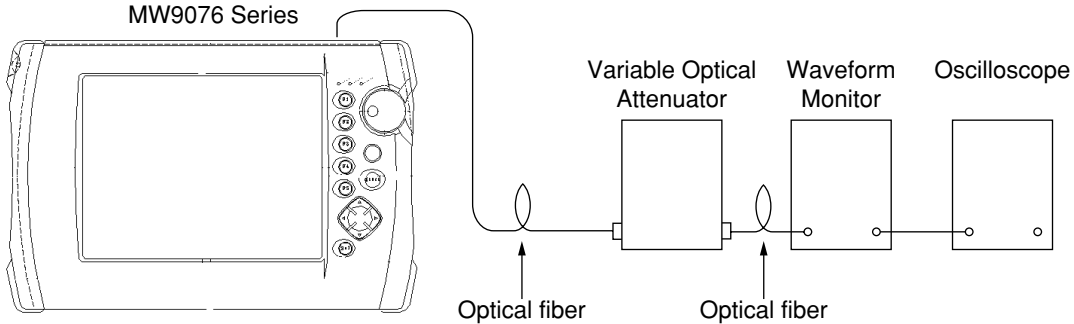

#### Test procedure

- (1) Set the pulse width to be measured on Setup screen 1. Check the wavelength and set it to a new value if necessary.
- (2) Press **Start**.
- (3) Adjust the oscilloscope amplitude and time axis scale and display the waveform on the oscilloscope. Adjust the variable optical attenuator so that the waveform monitor is not saturated.
- (4) Observe the waveform on the oscilloscope and measure the pulse width at an amplitude half its maximum value as shown in the figure below and check that the measurement result is within standard values.
- (5) To continue measurements at another pulse width, return to Setup screen 1 and change the pulse width and make a measurement from Step 2 above using the same procedure.

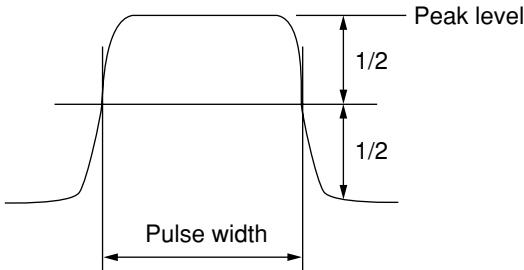

### 8.1.3 Dynamic range (one-way back-scattered light dynamic range test)

This test checks if the dynamic range conforms to specifications. This test is performed for each wavelength and pulse width.

#### Setup

Connect the units as shown in the figure below.

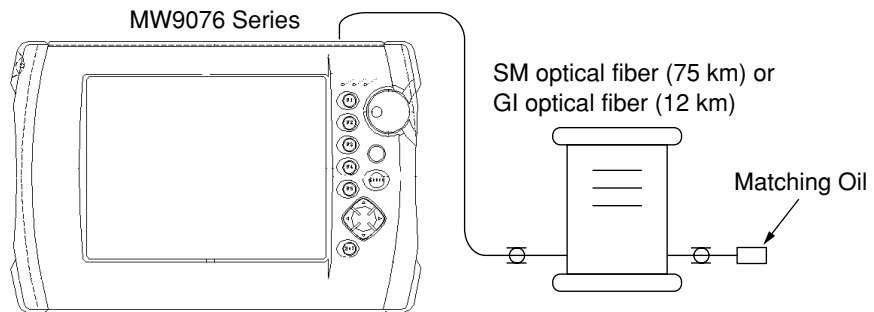

#### Test procedure

- (1) Set the parameters as shown below on Setup screen 1.
  - (a) Set Mode in Measurement mode to Manual.
  - (b) Set Wave Length (wavelength) in Measurement Parameters to the wavelength at which a measurement is to be performed.
  - (c) Set Distance (distance range) in Measurement Parameters to 100 km.
  - (d) Set Attenuation (attenuator) in Measurement Parameters to Auto.
  - (e) Set Pulse Width (pulse width) in Measurement Parameters to the pulse width to be measured.
  - (f) Set Average Limit Item in Measurement Parameters to Time and set the Average Limit Value to 180s.
- (2) Press **Start**.
- (3) Set the display mode to loss.
- (4) After averaging is completed, read the following value from the displayed waveform.
  - Difference between the level at the end of the optical connector in the OTDR and the peak level of floor noise.
- (5) Check that the level difference conforms to the specifications set for each wavelength and pulse width.

### 8.1.4 Horizontal axis accuracy

This test checks the accuracy of the horizontal scale, or the measured distance, by making a measurement on an optical fiber whose fiber length and IOR are known. This test needs to be performed only at one distance range.

#### Setup

Connect the units as shown in the figure below.

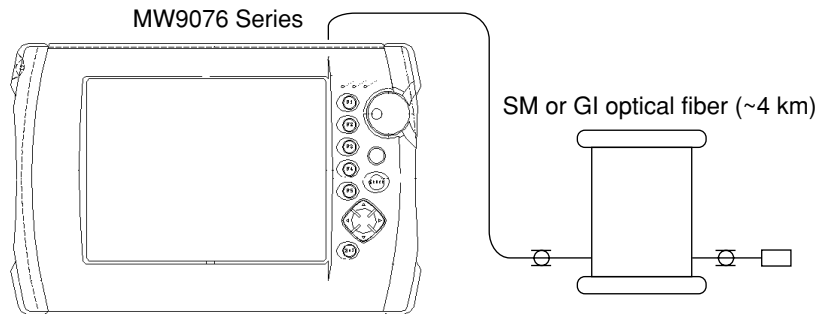

#### Test procedure

- (1) Set the parameters as shown below on Setup screen 1.
  - (a) Set Wave Length (wavelength) in Measurement Parameters.
  - (b) Set Distance (distance range) in Measurement Parameters to 5 km.
  - (c) Set Pulse Width (pulse width) in Measurement Parameters to the pulse width to be measured.
  - (d) Set IOR (index of refraction) in Measurement Parameters.
- (2) Press **Start**.
- (3) Put a marker at the far end Fresnel reflection and set the horizontal scale to 0.005 km/div.
- (4) Set Averaging to ON.
- (5) Precisely set the marker at the rising edge of the Fresnel reflection and read the absolute distance. Check that this value conforms to the specifications.

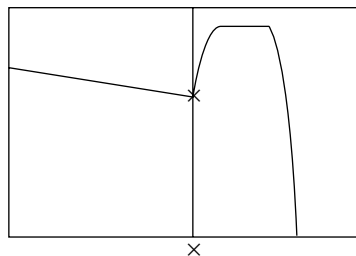

## 8.1.5 Vertical axis accuracy

This test checks the accuracy of the vertical scale, or the level measurement.

### Setup

Connect the units as shown in the figure below.

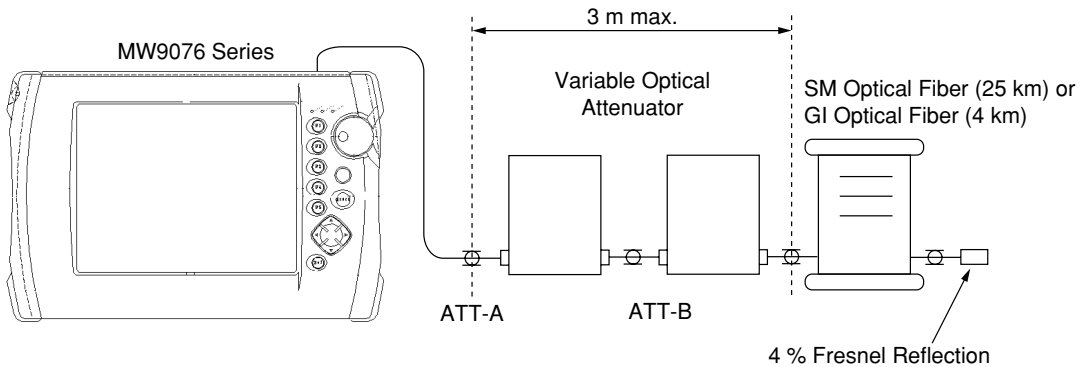

### Test procedure

- (1) Set the parameters as shown below on Setup screen 1.
  - (a) Set Wave Length (wavelength) in Measurement Parameters.
  - (b) Set Pulse Width (pulse width) in Measurement Parameters to 100 ns.
- (2) Press **Start**.
- (3) Set the loss display.
- (4) Set the × marker to the zero level and the \* marker to the far-end Fresnel reflection.
- (5) Set ATT-B to 0 dB, and then adjust ATT-A so that the far-end Fresnel reflection peak is slightly below the saturation level (within 0.2 dB).
- (6) Read the level of the Fresnel reflection from the OTDR screen and define this value as  $PL_0$ .
- (7) Set ATT-B to 0 dB and measure the level of Fresnel reflection. Define this value as  $PH_0$ .
- (8) Return ATT-B to 0 dB and increase the attenuation of ATT-A by 1 dB and measure the level of Fresnel reflection. Define this value as  $PL_i$ .
- (9) Set ATT-B to 2 dB and read the level of Fresnel reflection. Define this value as  $PH_i$ .
- (10) Increase the attenuation of ATT-A in 1 dB steps up to 15 dB to measure  $PL_i$  and  $PH_i$  at each step.
- (11) Obtain the vertical axis accuracy at each ATT-A setting using the following formula and check that they conforms to the specifications.
  - Vertical axis accuracy =  $\{ (PL_i - PH_i) - \Delta \} / \Delta A$   
 where,  $\Delta A$  is the difference between ATT-B settings at 0 dB and 2 dB (calibrated in advance).

### 8.1.6 Optical power level and wavelength of visible LD

This test can be performed when the visible LD option is installed.

#### Setup

Connect the units as shown in the figure below.

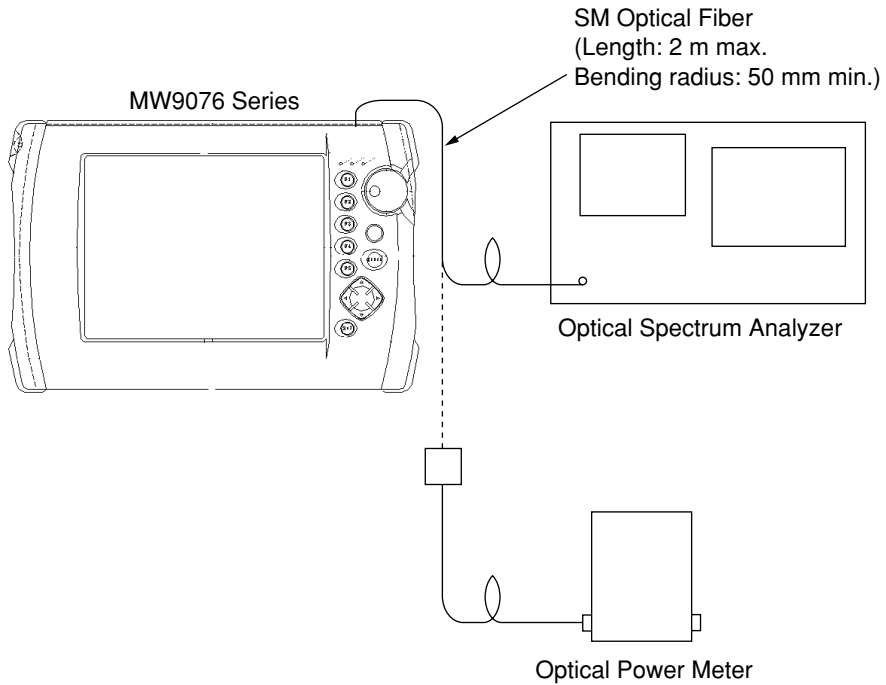

#### Test procedure

Set the Visible LD to ON in the Setup screen and measure the center wavelength with a spectrum analyzer and the optical output level with the optical power meter.

#### Note:

The performance test for wavelength and optical output level must be performed when the visible LD emits continuous light and not pulsed light.

### 8.1.7 Optical output level and wavelength of the light source

This test can be performed with the OTDR main unit equipped with a light source function (MW9076B/C).

#### Setup

Connect the units as shown in the figure below.

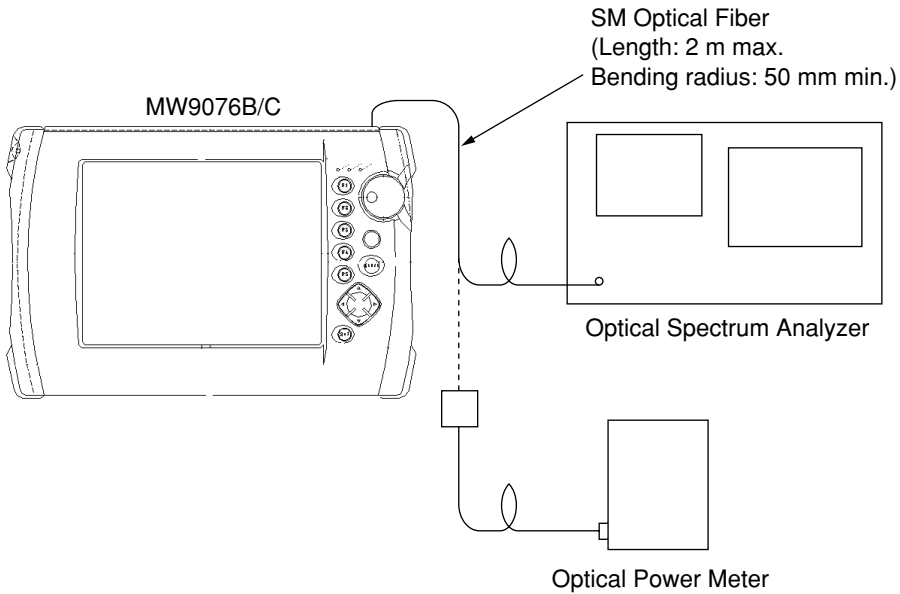

#### Test procedure

Using an optical power meter check that the light output meets the specifications.  
Using a spectrum analyzer check that the center wavelength and the spectral width meet the specifications.



### 8.1.8 Measurement range and accuracy of the power meter (options 02 and 03)

This test can be performed when the power meter option is installed in MW9076B/B1/C.

#### Setup (measurement range)

Connect the units as shown in the figure below.

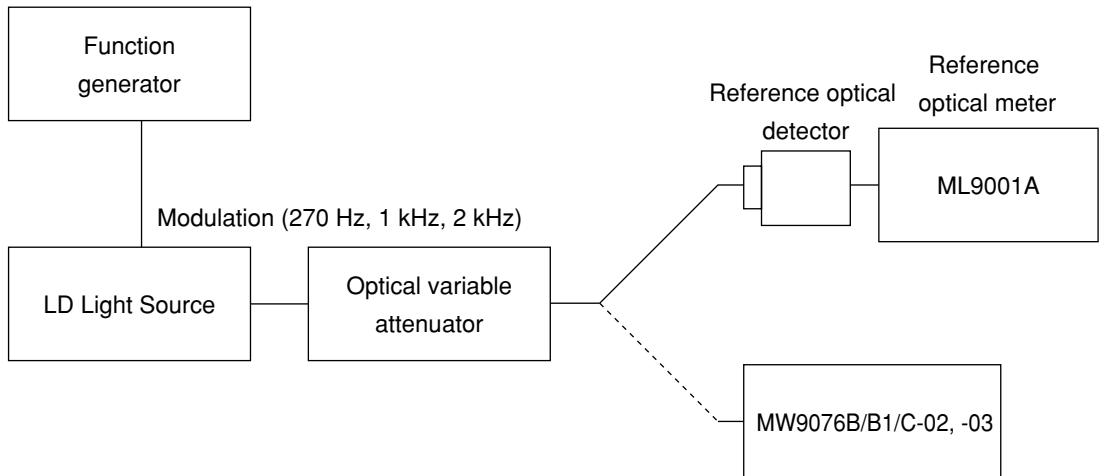

#### Test procedure (measurement range)

- (1) Connect the optical variable attenuator and the reference optical detector.
- (2) Adjust the optical variable attenuator so that the reading of the reference optical power meter is equal to the maximum measurement level.
- (3) Connect the optical variable attenuator and the device under test (DUT).
- (4) Read the indication value of the DUT, compare it with the maximum measurement level, and make adjustments so that the difference is within  $\pm 0.5$  dB.
- (5) Repeat Steps 1 to 4 above from 0 dBm up to the minimum measurement level plus 10 dB in increments of 10 dB.
- (6) Connect the optical variable attenuator and the reference optical detector, and adjust the optical variable attenuator so that the reference optical power meter reading is equal to the minimum measurement level.
- (7) Connect the optical variable attenuator and the DUT.
- (8) Read the indication value of the DUT, compare it with the minimum measurement level, and check that the difference is within  $\pm 1$  dB.

### Setup (accuracy)

Connect the units as shown in the figure below.

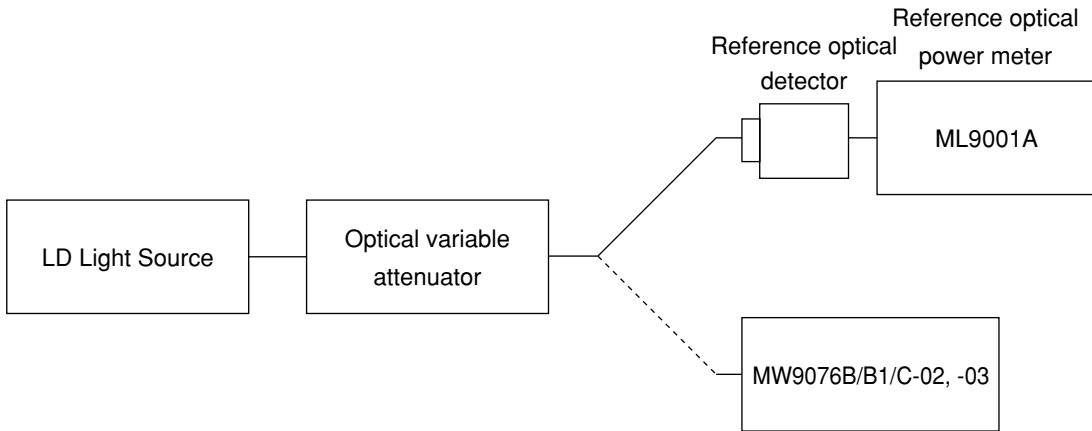

### Test procedure (accuracy)

The accuracy of the reference optical power meter is within 2 % of the national standard. The sum of the error of the reference optical power meter to the national standard and the error of the DUT to the reference optical power meter should be within  $\pm 5$  %.

Measure the accuracy at an input level of  $-10$  dBm, a measurement wavelength of  $1.31$  or  $1.55$   $\mu\text{m}$ , and an ambient temperature of  $25$   $^{\circ}\text{C}$ .

- (1) Connect the optical variable attenuator and the reference optical detector.
- (2) Adjust the optical variable attenuator so that the reading of the reference optical power meter is equal to  $-10.00$  dBm.
- (3) Connect the optical variable attenuator and the DUT.
- (4) Check that the reading of the DUT is equal to  $-10.0 \pm 0.2$  dBm.

### 8.1.9 Chromatic dispersion value (MW9076D/D1)

This item should be tested to check the performance of the chromatic dispersion function is fixed.

#### Set up

Connect the unit as shown in the figure below.

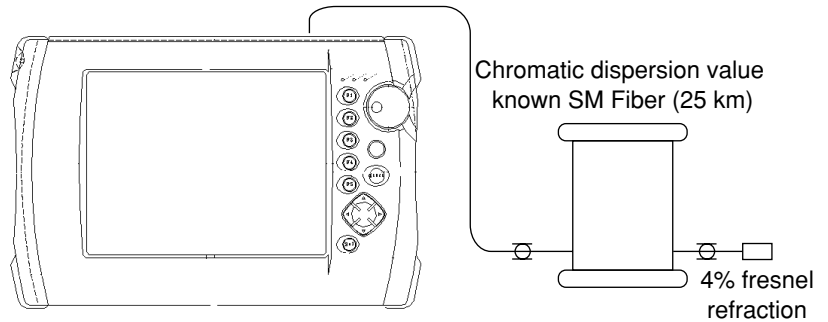

#### Test procedure

1. Connect the SM optical fiber cable (1.3  $\mu\text{m}$  zero dispersion) which is known the chromatic dispersion value.
2. Measure chromatic dispersion with the CD mode and confirm the measurement repeatability be within the specification.

### 8.1.10 Insertion loss of the optical channel selector (MU960001A/2A)

This item should be tested to check the performance of the optical channel selector (MU960001A/2A) is fixed.

#### Set up

Connect the unit as shown in the figure below.

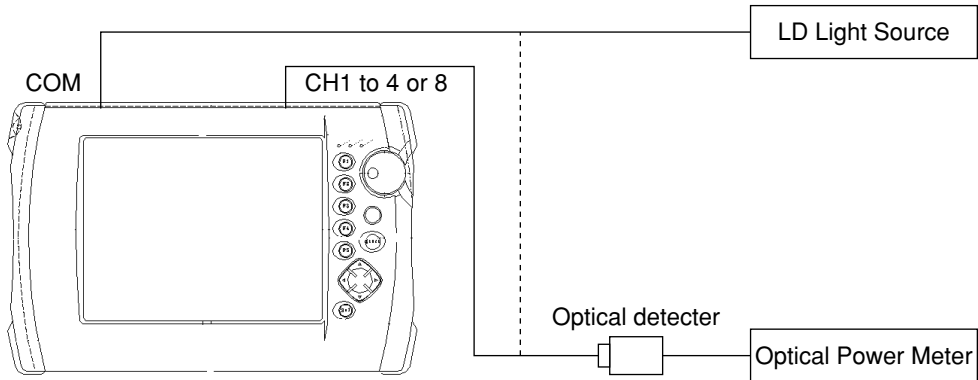

MW9076B/B1/C + MU960001A/2A + MU250000A/A1

#### Test procedure

1. Using an optical power meter, check the output power of LD light source (1.31/1.55  $\mu\text{m}$  CW)
2. Connect the LD light source output to COM port of MU960001A/2A.
3. Connect the power meter to each port (CH1 to 4 or 8) of MU960001A/2A and set the channel on the Setup mode (1/3) screen. Close Setup mode and check differences between the LD light source output power with/without MU960001A/2A.
4. Confirm the measurement result be within specification.

## 8.2 Calibration

Only the back-scattered level can be calibrated using the OTDR.

### Setup

Prepare an optical connector with a known return loss  $R_0$  dB and connect the units as shown in the figure below.

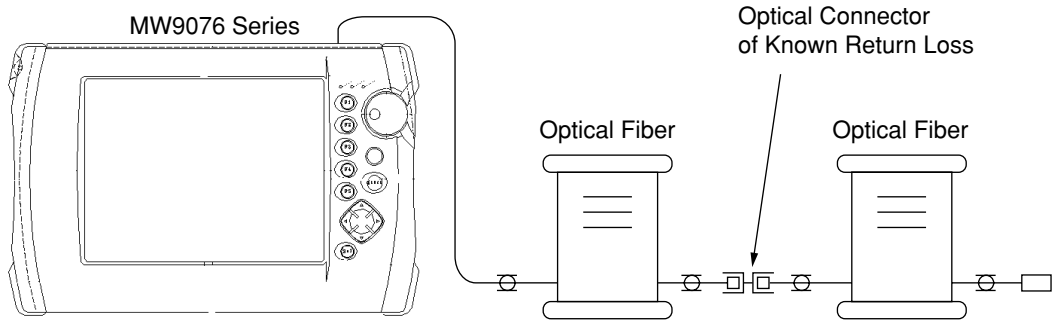

### Calibration procedure

- (1) Display Setup screen 1 and set Backscatter Level to 0 dB.
- (2) Press **Start**. After the measurement is completed, press **F3** (Splice & Return Loss) and select "Splice & Return Loss." Press **F4** (LSA) and set the linear approximation method to LSA. Set the \* and  $\nabla$  markers at the rising edge and the top of the Fresnel reflection, respectively.
- (3) Display the connector at the center of the screen in such a manner that as far as possible, the maximum length of the straight parts L1 and L2 before and after the connector are included in the screen and no other splices, connections, and fault points are included on the screen.

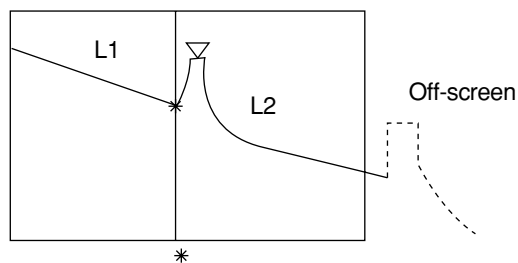

- (4) Set Averaging to ON and wait until the noise becomes minimum.
- (5) The Return loss is displayed at the bottom left of the screen. Define the value as  $R_1$  dB.
- (6) Obtain the difference between the value in Step 5 and  $R_0$  dB, the known value of the return loss of the optical connector ( $R_1 - R_0$ ). Set this value at Backscatter Level on Setup screen 1 together with its sign.
- (7) Return to the measurement screen. Calibration is completed when the displayed Return loss becomes equal to  $R_0$ .

## 8.3 Performance Test Result Record Form

Test location : \_\_\_\_\_  
\_\_\_\_\_

Report No. : \_\_\_\_\_  
Date : \_\_\_\_\_  
Tested by : \_\_\_\_\_

Unit name : \_\_\_\_\_  
Serial No. : \_\_\_\_\_

Ambient temperature : \_\_\_\_\_ °C      Power source frequency : \_\_\_\_\_ Hz  
Relative humidity : \_\_\_\_\_ %

Remarks : \_\_\_\_\_  
\_\_\_\_\_  
\_\_\_\_\_  
\_\_\_\_\_

## MW9076B OTDR main unit

Test item		Standard		Result		Remarks	
Center wavelength	1310 nm	±25 nm				Pulse width : 1 μs	
	1550 nm	±25 nm				Pulse width : 1 μs	
Pulse width	10 ns	10 ns					
	20 ns	20 ns					
	50 ns	50 ns					
	100 ns	100 ns					
	500 ns	500 ns					
	1000 ns	1000 ns					
	2000 ns	2000 ns					
	4000 ns	4000 ns					
	10000 ns	10000 ns					
	20000 ns	20000 ns					
Dynamic range	Wavelength (nm)	1310	1550	1310	1550		
	10 ns	8.9 dB	6.9 dB				
	20 ns	10.9 dB	8.9 dB				
	50 ns	12.9 dB	10.9 dB				
	100 ns	14.4 dB	12.4 dB				
	500 ns	22.4 dB	20.4 dB				
	1000 ns	24.4 dB	22.4 dB				
	2000 ns	25.9 dB	23.9 dB				
	4000 ns	29.9 dB	27.9 dB				
	10000 ns	37.4 dB	35.4 dB				
	20000 ns	39.9 dB	37.9 dB				
Horizontal axis accuracy		±1 m ±3 × measured distance × 10 <sup>-5</sup> ± marker resolution					
Vertical axis accuracy		±0.05 dB/dB or ±0.1 dB (whichever is greater)					
Visible LD	Center wavelength	635 ±15 nm				When Option 01 is installed	
	Optical output power	-3.0 ±1.5 dBm				When Option 01 is installed	
Light source	Center wavelength	1310 nm	±25 nm			CW	
		1550 nm	±25 nm			CW	
	Optical output power	1310 nm	-3.0 ±1.5 dBm			CW	
		1550 nm	-3.0 ±1.5 dBm			CW	
	Spectral width	1310 nm	5 nm or less				CW
1550 nm		10 nm or less				CW	
Power meter	Measurement range	Option 02	+3 dBm to -70 dBm +0 dBm to -75 dBm			CW Modulation	
		Option 03	+23 dBm to -50 dBm +20 dBm to -55 dBm			CW Modulation	
	Accuracy	Option 02	±5 %				-10 dBm, 1.31/1.55 CW
		Option 03	±5 %				-10 dBm, 1.31/1.55 CW

## Section 8 Performance Test and Calibration

### MW9076B1 OTDR main unit

Test item		Standard		Result		Remarks	
Center wavelength	1310 nm	±25 nm				Pulse width : 1 μs	
	1550 nm	±25 nm				Pulse width : 1 μs	
Pulse width	10 ns	10 ns					
	20 ns	20 ns					
	50 ns	50 ns					
	100 ns	100 ns					
	500 ns	500 ns					
	1000 ns	1000 ns					
	2000 ns	2000 ns					
	4000 ns	4000 ns					
	10000 ns	10000 ns					
	20000 ns	20000 ns					
Dynamic range	Wavelength (nm)	1310	1550	1310	1550		
	10 ns	8.9 dB	6.9 dB				
	20 ns	10.9 dB	8.9 dB				
	50 ns	12.9 dB	10.9 dB				
	100 ns	14.4 dB	12.4 dB				
	500 ns	22.4 dB	20.4 dB				
	1000 ns	24.4 dB	22.4 dB				
	2000 ns	25.9 dB	23.9 dB				
	4000 ns	29.9 dB	27.9 dB				
	10000 ns	33.9 dB	31.9 dB				
	20000 ns	35.4 dB	33.4 dB				
Horizontal axis accuracy		±1 m ±3 × measured distance × 10 <sup>-5</sup> ± marker resolution					
Vertical axis accuracy		±0.05 dB/dB or ± 0.1 dB (whichever is greater)					
Visible LD	Center wavelength	635 ± 15 nm				When Option 01 is installed	
	Optical output power	-3.0 ± 1.5 dBm				When Option 01 is installed	
Power meter	Measurement range	Option 02	+3 dBm to -70 dBm +0 dBm to -75 dBm				CW Modulation
		Option 03	+23 dBm to -50 dBm +20 dBm to -55 dBm				CW Modulation
	Accuracy	Option 02	±5 %				-10 dBm, 1.31/1.55 CW
		Option 03	±5 %				-10 dBm, 1.31/1.55 CW



MW9076C OTDR main unit

Test item		Standard			Result			Remarks
Center wavelength	1310 nm	±25 nm						Pulse width : 1 μs
	1550 nm	±25 nm						Pulse width : 1 μs
	1625 nm	±25 nm						Pulse width : 1 μs
Pulse width	10 ns	10 ns						
	20 ns	20 ns						
	50 ns	50 ns						
	100 ns	100 ns						
	500 ns	500 ns						
	1000 ns	1000 ns						
	2000 ns	2000 ns						
	4000 ns	4000 ns						
	10000 ns	10000 ns						
20000 ns	20000 ns							
Dynamic range	Wavelength (nm)	1310	1550	1625	1310	1550	1625	
	10 ns	8.9 dB	6.9 dB	4.4 dB				
	20 ns	10.9 dB	8.9 dB	6.4 dB				
	50 ns	12.9 dB	10.9 dB	8.4 dB				
	100 ns	14.4 dB	12.4 dB	9.9 dB				
	500 ns	22.4 dB	20.4 dB	17.9 dB				
	1000 ns	24.4 dB	22.4 dB	19.9 dB				
	2000 ns	25.9 dB	23.9 dB	21.4 dB				
	4000 ns	29.9 dB	27.9 dB	25.4 dB				
	10000 ns	36.4 dB	34.4 dB	31.9 dB				
20000 ns	38.9 dB	36.9 dB	34.4 dB					
Horizontal axis accuracy		±1 m ±3 × measured distance × 10 <sup>-5</sup> ± marker resolution						
Vertical axis accuracy		±0.05 dB/dB or ±0.1 dB (whichever is greater)						
Visible LD	Center wavelength	635 ±15 nm						When Option 01 is installed
	Optical output power	-3.0 ±1.5 dBm						When Option 01 is installed
Light source	Center wavelength	1310 nm	±25 nm					CW
		1550 nm	±25 nm					CW
		1625 nm	±25 nm					CW
	Optical output power	1310 nm	-3.0 ±1.5 dBm					CW
		1550 nm	-3.0 ±1.5 dBm					CW
		1625 nm	-3.0 ±1.5 dBm					CW
	Spectral width	1310 nm	5 nm or less					CW
		1550 nm	10 nm or less					CW
		1625 nm	10 nm or less					CW
Power meter	Measurement range	Option 02	+3 dBm to -70 dBm +0 dBm to -75 dBm					CW Modulation
		Option 03	+23 dBm to -50 dBm +20 dBm to -55 dBm					CW Modulation
	Accuracy	Option 02	±5 %					-10 dBm, 1.31/1.55 CW
		Option 03	±5 %					-10 dBm, 1.31/1.55 CW

## Section 8 Performance Test and Calibration

### MW9076D OTDR main unit

Test item		Standard				Result				Remarks
Center wavelength	1310 nm	±3 nm								Pulse width : 1 μs
	1410 nm	±3 nm								Pulse width : 1 μs
	1550 nm	±3 nm								Pulse width : 1 μs
	1625 nm	±3 nm								Pulse width : 1 μs
Pulse width	10 ns	10 ns								
	20 ns	20 ns								
	50 ns	50 ns								
	100 ns	100 ns								
	500 ns	500 ns								
	1000 ns	1000 ns								
	2000 ns	2000 ns								
	4000 ns	4000 ns								
	10000 ns	10000 ns								
	20000 ns	20000 ns								
Dynamic range	Wavelength (nm)	1310	1410	1550	1625	1310	1410	1550	1625	
	10 ns	-	-	-	-	-	-	-	-	
	20 ns	3.9 dB	2.9 dB	-	-	-	-	-	-	
	50 ns	5.9 dB	4.9 dB	3.9 dB	-					
	100 ns	7.4 dB	6.4 dB	5.4 dB	2.9 dB					
	500 ns	15.4 dB	14.4 dB	13.4 dB	10.9 dB					
	1000 ns	17.4 dB	16.4 dB	15.4 dB	12.9 dB					
	2000 ns	18.9 dB	17.9 dB	16.9 dB	14.4 dB					
	4000 ns	22.9 dB	21.9 dB	20.9 dB	18.4 dB					
	10000 ns	29.4 dB	28.4 dB	27.4 dB	24.9 dB					
	20000 ns	31.9 dB	30.9 dB	29.9 dB	27.4 dB					
Horizontal axis accuracy		±0.1 m ±3 × measured distance × 10 <sup>-5</sup> ± marker resolution								
Vertical axis accuracy		±0.05 dB/dB or ±0.1 dB (whichever is greater)								
Visible LD	Center wavelength	635 ±15 nm								When Option 01 is installed
	Optical output power	-3.0 ±1.5 dBm								When Option 01 is installed
Chromatic Dispersion	Dispersion Repeatability	± 0.05 ps/(nm•km)								Wavelength: 1.55 μm

## MW9076D1 OTDR main unit

Test item		Standard				Result				Remarks
Center wavelength	1310 nm	-3 nm								Pulse width : 1 $\mu$ s
	1450 nm	-3 nm								Pulse width : 1 $\mu$ s
	1550 nm	-3 nm								Pulse width : 1 $\mu$ s
	1625 nm	-3 nm								Pulse width : 1 $\mu$ s
Pulse width	10 ns	10 ns								
	20 ns	20 ns								
	50 ns	50 ns								
	100 ns	100 ns								
	500 ns	500 ns								
	1000 ns	1000 ns								
	2000 ns	2000 ns								
	4000 ns	4000 ns								
	10000 ns	10000 ns								
	20000 ns	20000 ns								
Dynamic range	Wavelength (nm)	1310	1450	1550	1625	1310	1450	1550	1625	
	10 ns	-	-	-	-	-	-	-	-	
	20 ns	3.9 dB	2.9 dB	-	-	-	-	-	-	
	50 ns	5.9 dB	4.9 dB	3.9 dB	-					
	100 ns	7.4 dB	6.4 dB	5.4 dB	2.9 dB					
	500 ns	15.4 dB	14.4 dB	13.4 dB	10.9 dB					
	1000 ns	17.4 dB	16.4 dB	15.4 dB	12.9 dB					
	2000 ns	18.9 dB	17.9 dB	16.9 dB	14.4 dB					
	4000 ns	22.9 dB	21.9 dB	20.9 dB	18.4 dB					
	10000 ns	29.4 dB	28.4 dB	27.4 dB	24.9 dB					
	20000 ns	31.9 dB	30.9 dB	29.9 dB	27.4 dB					
Horizontal axis accuracy		$\pm 0.1 \text{ m} \pm 3 \times \text{measured distance} \times 10^{-5} \pm \text{marker resolution}$								
Vertical axis accuracy		$\pm 0.05 \text{ dB/dB}$ or $\pm 0.1 \text{ dB}$ (whichever is greater)								
Visible LD	Center wavelength	635 $\pm$ 15 nm								When Option 01 is installed
	Optical output power	-3.0 $\pm$ 1.5 dBm								When Option 01 is installed
Chromatic Dispersion	Dispersion Repeatability	$\pm 0.05 \text{ ps}/(\text{nm} \cdot \text{km})$								Wavelength: 1.55 $\mu$ m

## Section 8 Performance Test and Calibration

### MW9076J OTDR main unit

Test item		Standard		Result	Remarks
Center wavelength	850 nm	$\pm 30$ nm			Pulse width : 100 ns
	1300 nm	$\pm 30$ nm			
Dynamic range	10 ns	11.3 dB			
	20 ns	13.3 dB			
	50 ns	15.3 dB			
	100 ns	18.4 dB			
Horizontal axis accuracy		$\pm 1$ m $\pm 3 \times$ measured distance $\times 10^{-5} \pm$ marker resolution			
Vertical axis accuracy		$\pm 0.05$ dB/dB or $\pm 0.1$ dB (whichever is greater)			
Visible LD	Center wavelength	635 $\pm 15$ nm			
	Optical output power	$-3.0 \pm 1.5$ dBm			

### MW9076K OTDR main unit

Test item		Standard		Result	Remarks
Center wavelength	850 nm	$\pm 30$ nm			Pulse width : 100 ns
	1300 nm	$\pm 30$ nm			
Dynamic range	Wavelength (nm)	850	1300		
	10 ns	11.3 dB	10.3 dB		
	20 ns	13.3 dB	12.3 dB		
	50 ns	15.3 dB	14.3 dB		
	100 ns	18.4 dB	15.8 dB		
	500 ns	-	19.3 dB		
	1000 ns	-	22.4 dB		
Horizontal axis accuracy		$\pm 1$ m $\pm 3 \times$ measured distance $\times 10^{-5} \pm$ marker resolution			
Vertical axis accuracy		$\pm 0.05$ dB/dB or $\pm 0.1$ dB (whichever is greater)			
Visible LD	Center wavelength	635 $\pm 15$ nm			
	Optical output power	$-3.0 \pm 1.5$ dBm			

MU960001A

Test item		Standard		Result		Remarks
Insertion loss	Wavelength (nm)	1310	1550	1310	1550	CW
	CH 1	≤2.5 dB				
	CH 2					
	CH 3					
	CH 4					

MU960002A

Test item		Standard		Result		Remarks
Insertion loss	Wavelength (nm)	1310	1550	1310	1550	CW
	CH 1	≤4.5 dB				
	CH 2					
	CH 3					
	CH 4					
	CH 5					
	CH 6					
	CH 7					
	CH 8					



# Section 9 Maintenance

---

This section explains how to clean the OTDR to maintain its performance, as well as how to detect abnormalities using the self-diagnosis function.

9.1	Optical Connector & Optical Adapter	
	Cleaning .....	9-2
9.2	Cleaning the Floppy Disk Drive .....	9-5
9.3	Self-Diagnosis .....	9-6
	9.3.1 Self-diagnosis at power on .....	9-6
	9.3.2 Self-diagnosis function .....	9-6
9.4	Suggestions for Storage .....	9-8
9.5	Method of Transportation .....	9-9

## 9.1 Optical Connector & Optical Adapter Cleaning

### Cleaning built-in ferrule end-face

Use adapter cleaner supplies for this unit to clean the built-in optical I/O connector ferrule. Clean the ferrule periodically. An example of the FC adapter is described below. Follow similar methods and steps for cleaning other adapters.

- (1) Pull the adapter lever up then gently pull the adapter out straight towards you after checking that the latch is released.

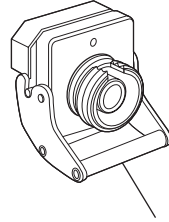

Adapter Lever

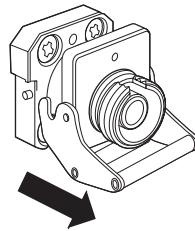
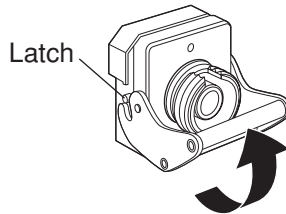

- (2) Clean by pressing the adapter cleaner which is soaked in alcohol to the ferrule end-face and side face.

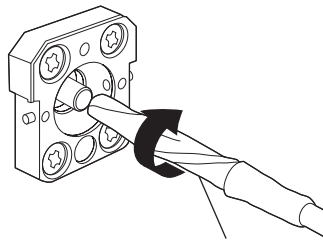

Adapter Cleaner



- (3) Finish by pressing the tip of a new adapter cleaner without any alcohol on it to the ferrule end-face and wipe in one direction 2 or 3 times.

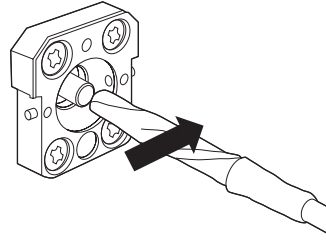

- (4) Clean the adapter interior with adapter cleaner.  
(Refer to “Cleaning optical adapter” below.)
- (5) Attach the adapter using the steps in reverse order. Be careful not to scratch the ferrule end-face.

### Cleaning optical adapter

Use adapter cleaner supplies for this unit to clean the optical adapter for connection to the fiber-optic cable. An example of the FC adapter is described below. Follow similar methods and steps for cleaning other adapters. In addition, clean the adapter which was removed to clean the built-in ferrule end-face using the following steps.

Insert the adapter cleaner to the split sleeve interior of the adapter then move it back and forth while rotating it in one direction.

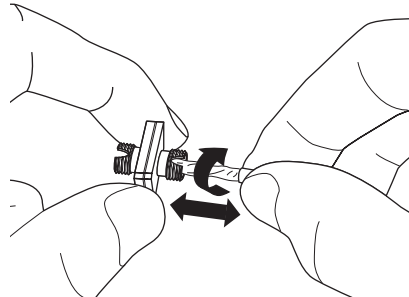

### Note:

Check the ferrule radius. Use only a  $\phi 1.25$  mm or  $\phi 2.5$  mm dedicated adapter cleaner.

**Cleaning the ferrule end-face of the fiber-optic cable**

Use ferrule cleaner supplies for this device to clean the ferrule of the cable end. An example of the FC connector is described below. Follow similar methods and steps for cleaning other connectors.

- (1) Lift the ferrule cleaner lever to access the cleaning face.

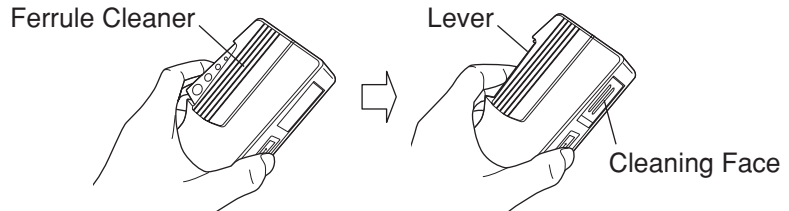

- (2) Keep the lever in this position then press down the ferrule end-face of the optical connector on the cleaning face and rub in one direction.

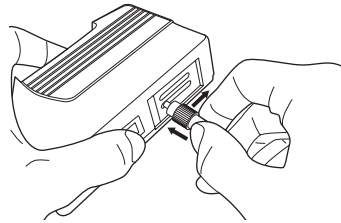

**Notes on cleaning**

- (1) Do not clean with used adapter cleaner.
- (2) Do not finish clean with a cotton swab as cotton fibers may adhere to the surface.
- (3) Make sure to cap adapters that are not in use.

**WARNING** ⚠

---

Ensure that no light is emitted when cleaning or checking the ferrule end-face.

---

**CAUTION** ⚠

---

Performance may be degraded if used when dust or dirt is adhering to the ferrule end-face. In addition, the connected fiber-optic cable & ferrule end-face of this unit may burn out if high-output light is used in this state. Clean the connected fiber-optic cable and ferrule end-face of this device before performing measurements.

---

## 9.2 Cleaning the Floppy Disk Drive

Dust may cause the floppy disk drive to malfunction. Therefore, it is necessary to periodically clean the floppy disk drive. Use a commercially available cleaning disk for the cleaning.

No particular disk is recommended by Anritsu. If you have any questions regarding the purchase of a cleaning disk, please feel free to contact Anritsu Corporation or your nearest service representative.

If the floppy disk does not work properly even after cleaning, there is a possibility of its failure. In this case please contact Anritsu Corporation or your nearest service representative for repairs.

## 9.3 Self-Diagnosis

### 9.3.1 Self-diagnosis at power on

The operating system (OS) installed in the OTDR checks the internal memory and the interface. If an error occurs, a message “Error” is displayed on the screen and operation stops.

If the message “Error” is displayed, turn off the power and then turn it on again. There is a possibility of failure if the message is displayed even after turning on the power. In this case please contact Anritsu Corporation or your nearest service representative for repairs.

The OTDR activates the internal program (Internal File System) after the OS has completed the above check. Therefore, it takes about one minute to display the Setup screen after the power is turned on.

If an error occurs during this period, the OTDR stops without displaying a message. If the Setup screen does not appear even after a lapse of one or two minutes, there is a possibility of failure. In this case please contact Anritsu Corporation or your nearest service representative for repairs.

### 9.3.2 Self-diagnosis function

The OTDR has a self-diagnosis function which can be used to check the internal program (Internal File System).

The procedure for executing the self-diagnosis function is shown below.

- (1) Make certain that the fiber is not connected to the I/O connector of the OTDR.
- (2) Press **Menu** on the measurement screen.
- (3) When the menu window opens, select Configuration with the **▲** and **▼** keys.
- (4) When Configuration is selected, the function key label F5 is indicated with Selftest.
- (5) When **F5** (Selftest) is pressed, the screen shown on the next page is displayed.

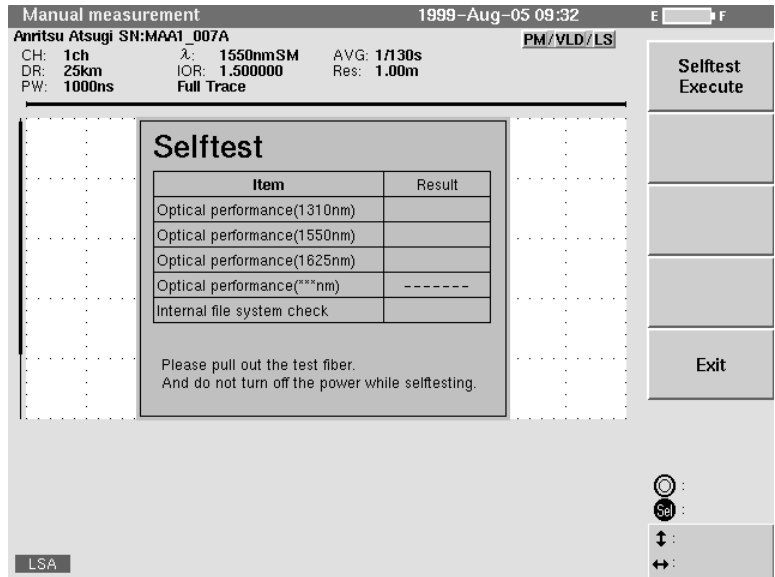

- (6) Pressing **F1** (Selftest Execute) starts the self-diagnosis test. Provided that an item is indicated with a horizontal line under Result in the Selftest window, it is not self-diagnosed.
- (7) If the self-diagnosis is successfully completed, OK (normal) or NG (abnormal) is displayed under Result in the Selftest window.

Execute self-diagnosis again when an error is occurred in Internal file System. The error may disappear if it is recovered. If NG is displayed even after self-diagnosis is executed again, there is a possibility of failure. In this case please contact Anritsu Corporation or your nearest service representative for repairs.

## CAUTION

**It takes about one minute to complete the self-diagnosis. Wait until it is completed (it cannot be stopped). If the power is turned off during self-diagnosis, the internal file system may be destroyed and the OTDR may not work properly.**

**When performing self-diagnosis, do not connect a fiber to the OTDR input/output connector. Self-diagnosis may not be executed properly.**

**Do not look into the connector because optical light is outputted from the OTDR input/output connector during self-diagnosis. It is recommended that the connector be covered with a dust cover.**

## 9.4 Suggestions for Storage

The following points should be kept in mind if the equipment is not to be used for a long period of time.

- (1) Store the equipment after removing the dust on it.
- (2) Do not store the equipment at a place where the temperature is greater than 60°C or less than -20°C, or where the humidity is greater than 85 %.
- (3) Do not store the equipment in a place where it is exposed to direct sunlight or dust.
- (4) Do not store the equipment in a place where there is a possibility of condensation or erosion by active gas.
- (5) Do not store the equipment in the place where there is a possibility of oxidation or strong vibrations.
- (6) It is recommended that the battery pack is removed from the equipment.

### **Recommended conditions for storage**

It is recommended that the equipment be stored in a place which satisfies the above requirements and the conditions below.

- (1) Temperature: from 5 to 30 °C
- (2) Humidity: from 40 to 75 %
- (3) Where the changes in temperature and humidity within one day are not large.

## 9.5 Method of Transportation

To transport this equipment, repack it using the packing materials used at the time of purchasing. If the packing materials have not been kept, repack it as indicated in step (3) and (4) below.

The repackaging procedure is as follows.

- (1) Clean the equipment surface with a dry cloth.
- (2) Check that the screws are tight.
- (3) Cover the projections and portions which can be easily deformed, and wrap this equipment in a polyester sheet.
- (4) Place the wrapped equipment into a corrugated paper box and seal the box with an adhesive tape. Then, insert this into a wooden box suitable for long-distance transportation.





These appendixes contain the following reference information.

Appendix A Specifications .....	A-1
(1) OTDR main unit (MW9076B/C) .....	A-1
(2) OTDR main unit (MW9076B1) .....	A-4
(3) OTDR main unit (MW9076D) .....	A-7
(4) OTDR main unit (MW9076D1) .....	A-10
(5) OTDR main unit (MW9076J) .....	A-13
(6) OTDR main unit (MW9076K) .....	A-16
(7) Display unit (MU250000A, MU250000A1, MU250000A4) .....	A-19
(8) Battery pack (CGR-B/802D or CGR-B/802E) .....	A-20
(9) AC adapter .....	A-20
(10) Visible LD (MW9076B/B1/C/D/D1/J/K-01) .....	A-20
(11) Optical power meter (MW9076B/B1/C-02) .....	A-21
(12) High input optical power meter (MW9076B/B1/C-03) .....	A-21
(13) Optical channel selector unit (MU960001A, MU960002A) .....	A-21
(14) Peripherals and parts .....	A-22
Appendix B Least Square Linear Approximation Method .....	B-1
Appendix C Splice Loss Measurement Principle ...	C-1
Appendix D Return Loss Measurement Principle ..	D-1
Appendix E Total Return Loss Measurement Principle .....	E-1
Appendix F Settings at Factory Shipment .....	F-1
Appendix G List of Recommended Printers .....	G-1
Appendix H Marker Resolution .....	H-1
Appendix I Simple OTDR Operation Method .....	I-1



# Appendix A Specifications

## (1) OTDR main unit (MW9076B/C)

Item	Standard	Remarks
Model name, unit name	MW9076B SMF 1.31/1.55 $\mu\text{m}$ OTDR MW9076C SMF 1.31/1.55/1.625 $\mu\text{m}$ OTDR	
Wavelength MW9076B MW9076C	1310/1550 $\pm$ 25 nm 1310/1550/1625 $\pm$ 25 nm	At 25 °C Pulse width: 1 $\mu\text{s}$
Fiber under test	10/125 m single mode fiber (ITU-T G.652)	
Optical connector	<ul style="list-style-type: none"> <li>• FC : Option 37</li> <li>• SC : Option 40</li> <li>• DIN : Option 39</li> <li>• HMS-10/A : Option 43</li> <li>• ST : Option 38</li> </ul> PC type FC•APC : Option 25 SC•APC : Option 26 HRL-10 : Option 47 APC type	Install one of them.  The connectors can be replaced by the user  Factory option
Automatic measurement *1 Measurement items Threshold value Splice loss Return loss Far end of fiber Detected events Auto setting Measurement time Connection check Communication light check	Total loss and Total return loss or Average loss Distance, splice loss, return loss, and reflectance of each event (Table display)  0.01 to 9.99 dB (0.01 dB increments) 20 to 60 dB (0.1 dB increments) 1 to 99 dB (1 dB increments) Up to 99 Distance range, pulse width, number of times of averaging (time) Within 60 seconds Check the connection status of mouth connector Check for communication light in the test optical fiber.	At Full Auto measurement
Manual measurement Measurement items Real time sweeping	Loss and distance between any two points, loss per unit length between two points, splice loss, return loss or reflectance, total return loss  Sweeping time: 0.1 to 0.2 seconds or less	At Quick mode

\*1 Automatic measurement is a supporting function which enables to operate easier, it doesn't assure results. As there is a case of miss detection, check the waveform as well.

## Appendix A Specifications

Item	Standard	Remarks
Distance range	1/2.5/5/10/25/50/100/200/250/400 km	IOR = 1.500000
Pulse width	10/20/50/100/500/1000/2000/4000/10000/20000 ns	
Dynamic range (SNR=1) MW9076B MW9076C	42.5/40.5 dB (1.31/1.55 $\mu$ m) Typical 45.0/43.0 (1.31/1.55 $\mu$ m) 41.5/39.5/37 dB (1.31/1.55/1.625 $\mu$ m)	At 25 °C, 20 $\mu$ s
Dead zone Back-scattered light Fresnel reflection	1.31 $\mu$ m : $\leq$ 8 m 1.55 $\mu$ m : $\leq$ 9 m 1.625 $\mu$ m : $\leq$ 12 m (MW9076C) 1.31 $\mu$ m : $\leq$ 1.6 m 1.55 $\mu$ m : $\leq$ 1.6 m 1.625 $\mu$ m : $\leq$ 1.6 m (MW9076C)	Pulse width: 10 ns Return loss: 40 dB Deviation: $\pm$ 0.1 dB Pulse width: 10 ns
Marker resolution	0.05 to 800 m	IOR = 1.500000
Sampling resolution	0.05 to 80 m	IOR = 1.500000
Number of sampling points Quick mode Normal mode High mode	5001 or 6251 20001 or 25001 40001 or 50001	*2
Vertical scale	0.25, 0.5, 1, 2.5, 5, 10, 15 dB/div	15 dB/div is indicated only at Auto and Full Auto measurement
IOR Settings	1.400000 to 1.699999 (0.000001 Steps)	
Distance measurement accuracy	$\pm 1 \text{ m} \pm 3 \times \text{measured distance} \times 10^{-5} \pm \text{marker resolution}$ * Uncertainty due to the index of refraction is excluded	
Loss measurement accuracy(linearity)	$\pm 0.05 \text{ dB/dB}$ or $\pm 0.1 \text{ dB}$ (whichever is greater)	
Return loss measurement accuracy	$\pm 2 \text{ dB}$	
Optical loss measurement light source Applicable fiber Optical connector Light emission element Central wavelength Spectral width Output level accuracy Optical output instantaneous stability: Output wavelength Warming up time Laser safety level	SM fiber (ITU-T G.652), PC Type Shared with OTDR (Same port) FP-LD 1310/1550 $\pm$ 25 nm (MW9076B) 1310/1550/1625 $\pm$ 25 nm (MW9076C) 5/10 nm or less (MW9076B) 5/10/10 nm or less (MW9076C) -3 $\pm$ 1.5 dBm 0.1 dB or less CW/270 Hz/1 kHz/2 kHz (Modulation light is square wave) Modulated frequency : 270 Hz/1 kHz/2 kHz $\pm$ 1.5 % 10 minutes 21CFRClass 1, IEC Pub60825-1Class 1	CW, at 25 °C CW, at 25 °C CW, at 25 °C, SM fiber 2 m, CW, one point at -10 to +40 °C ( $\pm$ 1 °C), Difference between the maximum and minimum values in one minute period. SM fiber 2 m

\*2 Either value is automatically selected in each mode, depending on the distance range.

Item		Standard	Remarks
Other functions		<ul style="list-style-type: none"> <li>• Waveform storage: Analysis format, Standard (GR-196-CORE) format, Standard.V2 (SR-4731) format</li> <li>• Printout: Centronics</li> <li>• Continuous measurement: Wavelength switching, waveform storage, and series of operations such as print-out can be performed with a single key stroke</li> <li>• Relative distance setting (zero cursor setting)</li> <li>• Waveform comparison</li> <li>• Calendar function</li> <li>• Distance unit setting: km, kf, mi, m, f</li> <li>• Title entry: 32 characters</li> <li>• Battery indication</li> </ul>	
Laser safety		21CFRClass 1, IEC Pub60825-1Class 1	
Power supply		Power is supplied from the MU250000A/A1 display unit. Refer to the specifications of the MU250000A/A1.	
Power consumption		35W max. (when charged), Standard 4 W	Including MU250000A power consumption
Continuous battery operation		6 h (typical) (CGR-B/802D) 7 h (typical) (CGR-B/802E)	Backlight low, measurement not executed
Dimension		194H × 290W × 30D mm 194H × 290W × 75D mm	MW9076B/C only Including MU250000A
Mass		1.4 kg or less (MW9076B/C only) 4.0 kg or less (including MU250000A, battery pack)	
Environmental conditions			
Operating temperature, humidity		-10 to +40 °C, ≤85 %	No condensation
Storage temperature, humidity		-20 to +60 °C, ≤85 %	
Vibration		Conforms to MIL-T-28800E Class 3	
Drop test		Height 76 cm, 6 surfaces, 8 corners	On a plywood 5 cm thick fixed on a concrete floor
Dust-proof		MIL-T-28800E	
Water-proof		MIL-T-28800E	
EMC	Emission	EN 61326-1: 2006 (Class A) EN 61000-3-2: 2006 (Class A equipment)	
	Immunity	EN 61326-1: 2006 (Table 2)	

## Appendix A Specifications

### (2) OTDR main unit (MW9076B1)

Item	Standard	Remarks
Model name, unit name	MW9076B1 SMF 1.31/1.55 $\mu$ m OTDR	
Wavelength	1310/1550 $\pm$ 25 nm	At 25 °C Pulse width: 1 $\mu$ s
Fiber under test	10/125 $\mu$ m single mode fiber (ITU-T G.652)	
Optical connector	<ul style="list-style-type: none"> <li>• FC : Option 37</li> <li>• SC : Option 40</li> <li>• DIN : Option 39</li> <li>• HMS-10/A : Option 43</li> <li>• ST : Option 38</li> </ul> PC type	Install one of them  The connectors can be replaced by the user
Automatic measurement *1		
Measurement items	Total loss and Total return loss or Average loss Distance, splice loss, return loss, and reflectance of each event (Table display)	
Threshold value		
Splice loss	0.01 to 9.99 dB (0.01 dB increments)	
Return loss	20 to 60 dB (0.1 dB increment)	
Far end of fiber	1 to 99 dB (1 dB increment)	
Detected events	Up to 99	
Auto setting	Distance range, pulse width, number of times of averaging (time)	
Measurement time		
At Full Auto measurement	Within 60 seconds	At Full Auto measurement
Connection check	Check the connection status of the light source connector	
Communication light check	Check for communication light in the test optical fiber.	
Manual measurement		
Measurement items	Loss and distance between any two points, loss per unit length between two points, splice loss, return loss or reflectance, total return loss	
Real time sweeping	Sweeping time: 0.1 to 0.2 seconds or less	At Quick mode

\*1 Automatic measurement is a supporting function which enables to operate easier, it doesn't assure results. As there is a case of miss detection, check the waveform as well.

Item	Standard	Remarks
Distance range	1/2.5/5/10/25/50/100/200/250/400 km	IOR = 1.500000
Pulse width	10/20/50/100/500/1000/2000/4000/10000/20000 ns	
Dynamic range (SNR=1)	38/36 dB (1.31/1.55 $\mu\text{m}$ ) Typical 40.5/38.5 dB (1.31/1.55 $\mu\text{m}$ )	At 25 °C, 20 $\mu\text{s}$
Dead zone		
Back-scattered light	1.31 $\mu\text{m}$ : $\leq 8$ m 1.55 $\mu\text{m}$ : $\leq 9$ m	Pulse width 10 ns Return loss 40 dB Deviation: $\pm 0.1$ dB
Fresnel reflection	1.31 $\mu\text{m}$ : $\leq 1.6$ m 1.55 $\mu\text{m}$ : $\leq 1.6$ m	Pulse width 10 ns
Marker resolution	0.05 to 800 m	IOR = 1.500000
Sampling resolution	0.05 to 80 m	IOR = 1.500000
Number of sampling points		*2
Quick mode	5001 or 6251	
Normal mode	20001 or 25001	
High mode	40001 or 50001	
Vertical scale	0.25, 0.5, 1, 2.5, 5, 10, 15 dB/div	15 dB/div is indicated only at Auto and Full Auto measurement
IOR Setting	1.400000 to 1.699999 (0.000001 steps)	
Distance measurement accuracy	$\pm 1 \text{ m} \pm 3 \times \text{measured distance} \times 10^{-5} \pm \text{marker resolution}$ * Uncertainty due to the index of refraction is excluded	
Loss measurement accuracy(linearity)	$\pm 0.05 \text{ dB/dB}$ or $\pm 0.1 \text{ dB}$ (whichever is greater)	
Return loss measurement accuracy	$\pm 2 \text{ dB}$	
Optical loss measurement light source	None	
Other functions	<ul style="list-style-type: none"> <li>• Waveform storage:     Analysis format, Standard (GR-196-CORE) format, Standard.V2 (SR-4731) format</li> <li>• Printout: Centronics</li> <li>• Continuous measurement:     Wavelength switching, waveform storage</li> <li>• A series of operations such as print-out can be performed with a single key stroke</li> <li>• Relative distance setting (zero cursor setting)</li> <li>• Waveform comparison</li> <li>• Calendar function</li> <li>• Distance unit setting: km, kf, mi, m, f</li> <li>• Title character entry: 32 characters</li> <li>• Battery indication</li> </ul>	

\*2 Either value is automatically selected in each mode, depending on the distance range.

**Appendix A Specifications**

Item		Standard	Remarks
Laser safety		21CFRClass 1, IEC Pub60825-1Class 1	
Power supply		Power is supplied from the MU250000A display unit. Refer to the specifications of MU250000A.	
Power consumption		35 W max. (when charged), Standard 4 W	Including MU250000A power consumption
Continuous battery operation		6 h (typical) (CGR-B/802D) 7 h (typical) (CGR-B/802E)	Backlight low, measurement not executed
Dimension		194 (H) × 290 (W) × 30 (D) mm 194 (H) × 290 (W) × 75 (D) mm	MW9076B1 only Including MU250000A
Mass		1.4 kg or less (MW9076B1 only) 4.0 kg or less (including MU250000A, battery pack)	
Environmental conditions			
Operating temperature, humidity		-10 to +40 °C, ≤85 %	No condensation  On a plywood 5 cm thick fixed on a concrete floor
Storage temperature, humidity		-20 to +60 °C, ≤85 %	
Vibration		Conforms to MIL-T-28800E Class 3	
Drop test		Height 76 cm, 6 surfaces, 8 corners	
Dust-proof		MIL-T-28800E	
Water-proof		MIL-T-28800E	
EMC	Emission	EN 61326-1: 2006 (Class A) EN 61000-3-2: 2006 (Class A equipment)	
	Immunity	EN 61326-1: 2006 (Table 2)	



## (3) OTDR main unit (MW9076D)

Item	Standard	Remarks
Model name, unit name	MW9076D SMF 1.31/1.41/1.55/1.625 mm OTDR	
Wavelength	1310/1410/1550/1625 $\pm$ 3 nm	At 25 °C Pulse width : 1 $\mu$ s
Fiber under test	10/125 mm single mode fiber (ITU-T G.652)	
Optical connector	<ul style="list-style-type: none"> <li>• FC : Option 37</li> <li>• SC : Option 40</li> <li>• DIN : Option 39</li> <li>• HMS-10/A : Option 43</li> <li>• ST : Option 38</li> </ul> PC type	Install one of them.  The connectors can be replaced by the user
Automatic measurement *1		
Measurement items	Total loss and Total return loss or Average loss Distance, splice loss, return loss, and reflectance of each event (Table display)	
Threshold value		
Splice loss	0.01 to 9.99 dB (0.01 dB increments)	
Return loss	20 to 60 dB (0.1 dB increment)	
Far end of fiber	1 to 99 dB (1 dB increment)	
Detected events	Up to 99	
Auto setting	Distance range, pulse width, number of times of averaging (time)	
Measurement time	Within 60 seconds	At Full Auto measurement
Connection check	Check the connection status of mouth connector.	
Communication light check	Check for communication light in the test optical fiber.	
Manual measurement		
Measurement items	Loss and distance between any two points, loss per unit length between two points, splice loss, return loss or reflectance, total return loss	
Real time sweeping	Sweeping time: 0.1 to 0.2 seconds or less	At Quick mode

\*1 Automatic measurement is a supporting function which enables to operate easier, it doesn't assure results. As there is a case of miss detection, check the waveform as well.

## Appendix A Specifications

Item	Standard	Remarks
Distance range	1/2.5/5/10/25/50/100/200/250/400 km	IOR = 1.500000
Pulse width	10/20/50/100/500/1000/2000/4000/10000/20000 ns	
Dynamic range (SNR=1)	34.5/33.5/32.5/30.0 dB (1.31/1.41/1.55/1.625 $\mu$ m)	At 25 °C, 20 $\mu$ s
Dead zone		
Back-scattered light	$\leq 25$ m	Pulse width 50 ns Return loss 40 dB Deviation: $\pm 0.1$ dB
Fresnel reflection	$\leq 3$ m	Pulse width 10 ns
Marker resolution	0.05 to 800 m	IOR = 1.500000
Sampling resolution	0.05 to 80 m	IOR = 1.500000
Number of sampling points		*2
Quick mode	5001 or 6251	
Normal mode	20001 or 25001	
High mode	40001 or 50001	
Vertical scale	0.25, 0.5, 1, 2.5, 5, 10, 15 dB/div	15 dB/div is indicated only at Auto and Full Auto measurement
IOR Setting	1.400000 to 1.699999 (0.000001 steps)	
Distance measurement accuracy	$\pm 0.1$ m $\pm 3 \times$ measured distance $\times 10^{-5}$ $\pm$ marker resolution * Uncertainty due to the index of refraction is excluded	
Loss measurement accuracy	$\pm 0.05$ dB/dB or $\pm 0.1$ dB (whichever the greater)	
Return loss measurement accuracy	$\pm 2$ dB	
Optical loss measurement light source	None	
Chromatic dispersion measurement function	Wavelength range 1300 to 1660 nm Wavelength accuracy $\pm 0.5$ nm* <sup>3</sup> (typical) Zero-dispersion repeatability $\pm 0.6$ nm* <sup>4</sup> (typical) Dispersion repeatability $\pm 0.05$ ps/(nm·km)* <sup>4</sup> (typical) Dynamic range 30 dB (4% Fresnel, typical)	Wavelength 1.55 $\mu$ m SMF 25 km

\*2 Either value is automatically selected in each mode, depending on the distance range.

\*3 Compared value with internal wavelength data at chromatic dispersion measurement

\*4 Measured with 25 km of 1.3  $\mu$ m zero-dispersion fiber. Not an error from absolute value but repeatability of measured results. Dispersion repeatability is the value of 1.55  $\mu$ m wavelength. Contact Anritsu in case of measuring ITU-T G.655 fiber.

Item		Standard	Remarks
Other functions		<ul style="list-style-type: none"> <li>• Waveform storage: Analysis format, Standard (GR-196-CORE) format, Standard.V2 (SR-4731) format</li> <li>• Printout: Centronics</li> <li>• Continuous measurement: Wavelength switching, waveform storage A series of operations such as print-out can be performed with a single key stroke</li> <li>• Relative distance setting (zero cursor setting)</li> <li>• Waveform comparison</li> <li>• Calendar function</li> <li>• Distance unit setting: km, kf, mi, m, f</li> <li>• Title entry: 32 characters</li> <li>• Battery indication</li> </ul>	
Laser safety		21 CFR Class 1, IEC Pub60825-1 Class 1	
Power supply		Power is supplied from the MU250000A display unit Refer to the specifications of MU250000A.	
Power consumption		35W at max. (when charged), Standard 4W	Including MU250000A power consumption
Continuous battery operation		6 h (typical) (CGR-B/802D) 7 h (typical) (CGR-B/802E)	Backlight low, measurement not executed
Dimension		194H × 290W × 77D mm 194H × 280W × 122D mm	MW9076D only Including MU250000A
Mass		3.1 kg or less (MW9076D only) 5.7 kg or less (including MU250000A, battery pack)	
Environmental conditions			No condensation
Operating temperature, humidity		-10 to +40 °C, ≤85 %	
Storage temperature, humidity		-20 to +60 °C, ≤85 %	
Vibration		Conforms to MIL-T-28800E Class 3	
Dust-proof		MIL-T-28800E	
Water-proof		MIL-T-28800E	
EMC	Emission	EN 61326-1: 2006 (Class A) EN 61000-3-2: 2006 (Class A equipment)	
	Immunity	EN 61326-1: 2006 (Table 2)	

## Appendix A Specifications

### (4) OTDR main unit (MW9076D1)

Item	Standard	Remarks
Model name, unit name	MW9076D1 SMF 1.31/1.45/1.55/1.625 μm OTDR	
Wavelength	1310/1450/1550/1625 ±3 nm	At 25 °C Pulse width : 1 μs
Fiber under test	10/125 μm single mode fiber (ITU-T G.652)	
Optical connector	<ul style="list-style-type: none"> <li>• FC : Option 37</li> <li>• SC : Option 40</li> <li>• DIN : Option 39</li> <li>• HMS-10/A : Option 43</li> <li>• ST : Option 38</li> </ul> PC type	Install one of them.  The connectors can be replaced by the user
Automatic measurement *1		
Measurement items	Total loss and Total return loss or Average loss Distance, splice loss, return loss, and reflectance of each event (Table display)	
Threshold value		
Splice loss	0.01 to 9.99 dB (0.01 dB increments)	
Return loss	20 to 60 dB (0.1 dB increment)	
Far end of fiber	1 to 99 dB (1 dB increment)	
Detected events	Up to 99	
Auto setting	Distance range, pulse width, number of times of averaging (time)	
Measurement time	Within 60 seconds	At Full Auto measurement
Connection check	Check the connection status of mouth connector.	
Communication light check	Check for communication light in the test optical fiber.	
Manual measurement		
Measurement items	Loss and distance between any two points, loss per unit length between two points, splice loss, return loss or reflectance, total return loss	
Real time sweeping	Sweeping time: 0.1 to 0.2 seconds or less	At Quick mode

\*1 Automatic measurement is a supporting function which enables to operate easier, it doesn't assure results. As there is a case of miss detection, check the waveform as well.

Item	Standard	Remarks
Distance range	1/2.5/5/10/25/50/100/200/250/400 km	IOR = 1.500000
Pulse width	10/20/50/100/500/1000/2000/4000/10000/20000 ns	
Dynamic range (SNR=1)	34.5/33.5/32.5/30.0 dB (1.31/1.45/1.55/1.625 $\mu$ m)	At 25 °C, 20 $\mu$ s
Dead zone Back-scattered light	$\leq 25$ m	Pulse width 50 ns Return loss 40 dB Deviation: $\pm 0.1$ dB
Fresnel reflection	$\leq 3$ m	Pulse width 10 ns
Marker resolution	0.05 to 800 m	IOR = 1.500000
Sampling resolution	0.05 to 80 m	IOR = 1.500000
Number of sampling points Quick mode Normal mode High mode	5001 or 6251 20001 or 25001 40001 or 50001	*2
Vertical scale	0.25, 0.5, 1, 2.5, 5, 10, 15 dB/div	15 dB/div is indicated only at Auto and Full Auto measurement
IOR Setting	1.400000 to 1.699999 (0.000001 steps)	
Distance measurement accuracy	$\pm 0.1$ m $\pm 3 \times$ measured distance $\times 10^{-5} \pm$ marker resolution * Uncertainty due to the index of refraction is excluded	
Loss measurement accuracy	$\pm 0.05$ dB/dB or $\pm 0.1$ dB (whichever the greater)	
Return loss measurement accuracy	$\pm 2$ dB	
Optical loss measurement light source	None	
Chromatic dispersion measurement function	Wavelength range 1300 to 1660 nm Wavelength accuracy $\pm 0.5$ nm* <sup>3</sup> (typical) Zero-dispersion repeatability $\pm 0.6$ nm* <sup>4</sup> (typical) Dispersion repeatability $\pm 0.05$ (ps/nm·km)* <sup>4</sup> (typical) Dynamic range 30 dB (4% Fresnel, typical)	Wavelength 1.55 $\mu$ m SMF 25 km

\*2 Either value is automatically selected in each mode, depending on the distance range.

\*3 Compared value with internal wavelength data at chromatic dispersion measurement

\*4 Measured with 25 km of 1.3  $\mu$ m zero-dispersion fiber. Not an error from absolute value but repeatability of measured results. Dispersion repeatability is the value of 1.55  $\mu$ m wavelength. Contact Anritsu in case of measuring ITU-T G.655 fiber.

## Appendix A Specifications

Item		Standard	Remarks
Other functions		<ul style="list-style-type: none"> <li>• Waveform storage: Analysis format, Standard (GR-196-CORE) format, Standard.V2 (SR-4731) format</li> <li>• Printout: Centronics</li> <li>• Continuous measurement: Wavelength switching, waveform storage A series of operations such as print-out can be performed with a single key stroke</li> <li>• Relative distance setting (zero cursor setting)</li> <li>• Waveform comparison</li> <li>• Calendar function</li> <li>• Distance unit setting: km, kf, mi, m, f</li> <li>• Title entry: 32 characters</li> <li>• Battery indication</li> </ul>	
Laser safety		21 CFR Class 1, IEC Pub60825-1 Class 1	
Power supply		Power is supplied from the MU250000A display unit Refer to the specifications of MU250000A.	
Power consumption		35W at max. (when charged), Standard 4W	Including MU250000A power consumption
Continuous battery operation		6 h (typical) (CGR-B/802D) 7 h (typical) (CGR-B/802E)	Backlight low, measurement not executed
Dimension		194H × 290W × 77D mm 194H × 280W × 122D mm	MW9076D1 only Including MU250000A
Mass		3.1 kg or less (MW9076D1 only) 5.7 kg or less (including MU250000A, battery pack)	
Environmental conditions			No condensation
Operating temperature, humidity		-10 to +40 °C, ≤85 %	
Storage temperature, humidity		-20 to +60 °C, ≤85 %	
Vibration		Conforms to MIL-T-28800E Class 3	
Dust-proof		MIL-T-28800E	
Water-proof		MIL-T-28800E	
EMC	Emission	EN 61326-1: 2006 (Class A) EN 61000-3-2: 2006 (Class A equipment)	
	Immunity	EN 61326-1: 2006 (Table 2)	

## (5) OTDR main unit (MW9076J)

Item	Standard	Remarks
Model name, unit name	MW9076J GIF 0.85 $\mu$ m OTDR	
Wavelength	850 $\pm$ 30 nm	At 25 °C Pulse width: 100 ns
Fiber under test	62.5/125 m multi-mode fiber *2	
Optical connector	<ul style="list-style-type: none"> <li>• FC : Option 37</li> <li>• ST : Option 38</li> <li>• DIN : Option 39</li> <li>• SC : Option 40</li> </ul> PC type	Install one of them  The connectors can be replaced by the user
Automatic measurement *1	Total loss and total return loss Distance, splice loss, return loss, and reflectance of each event (Table display)	
Measurement items		
Threshold value	0.01 to 9.99 dB (0.01 dB increments)	
Splice loss	20 to 60 dB (0.1 dB increment)	
Return loss	1 to 99 dB (1 dB increment)	
Far end of fiber	Up to 99	
Detected events	Distance range, pulse width, number of times of averaging (time)	
Auto setting	Within 60 seconds	At Full Auto measurement
Measurement time	Check the connection status of the light source connector	
Connection check	Check for communication light in the test optical fiber.	
Communication light check		
Manual measurement		
Measurement items	Loss and distance between any two points, loss per unit length between two points, splice loss, return loss or reflectance, total return loss	
Real time sweeping	Sweeping time: 0.1 to 0.2 seconds or less	At Quick mode

\*1 Automatic measurement is a supporting function which enables to operate easier, it doesn't assure results. As there is a case of miss detection, check the waveform as well.

\*2 This specification is defined with the GI fiber of Core diameter: 62.5  $\pm$  3  $\mu$ m, NA: 0.275 $\pm$ 0.015, Loss:  $\leq$  3.2/0.9 [dB/km] (Wavelength 0.85/1.3  $\mu$ m).

When a 50/125  $\mu$ m optical fiber is used, the dynamic range becomes narrower by approximately 3 dB.

## Appendix A Specifications

Item	Standard	Remarks
Distance range	1/2.5/5/10/25/50/100 km	IOR = 1.500000
Pulse width	10/20/50/100 ns	
Dynamic range (SNR=1)	21 dB	At 25°C, 100 ns
Dead zone		
Back-scattered light	≤7 m	Pulse width: 10 ns Return loss: 30 dB Deviation: ± 0.5 dB
	≤50 m	Deviation: ± 0.1 dB
Fresnel reflection	≤2 m	Pulse width: 10 ns
Marker resolution	0.05 to 200 m	IOR = 1.500000
Sampling resolution	0.05 to 20 m	IOR = 1.500000
Number of sampling points		*3
Quick mode	5001 or 6251	
Normal mode	20001 or 25001	
High mode	40001 or 50001	
Vertical scale	0.25, 0.5, 1, 2.5, 5, 10, 15 dB/div	15 dB/div is indicated only at Auto and Full Auto measurement
IOR Setting	1.400000 to 1.699999 (0.000001 steps)	
Distance measurement accuracy	±1 m ±3 × measured distance × 10 <sup>-5</sup> ± marker resolution * Uncertainty due to the index of refraction is excluded	
Loss measurement accuracy (linearity)	±0.05 dB/dB or ± 0.1 dB (whichever the greater)	
Return loss measurement accuracy	±4 dB	
Other functions	<ul style="list-style-type: none"> <li>• Waveform storage:     Analysis format, Standard (GR-196-CORE) format, Standard.V2 (SR-4731) format</li> <li>• Printout: Centronics</li> <li>• Continuous measurement:     Wavelength switching, waveform storage     A series of operations such as print-out can be performed with a single key stroke</li> <li>• Relative distance setting (zero cursor setting)</li> <li>• Waveform comparison</li> <li>• Calendar function</li> <li>• Distance unit setting: m, km, f, kf, mi</li> <li>• Title entry: 32 characters</li> <li>• Battery indication</li> </ul>	

\*3 Either value is automatically selected in each mode, depending on the distance range.



Item		Standard	Remarks
Laser safety		21CFRClass 1, IEC Pub60825-1Class 1	
Power supply		Power is supplied from the MU250000A display unit. Refer to the specifications of MU250000A.	
Power consumption		35 W max. (when charged), Standard 4 W	Including MU250000A power consumption
Continuous battery operation		6 h (typical) (CGR-B/802D) 7 h (typical) (CGR-B/802E)	Backlight low, measurement not executed
Dimension		194 (H) × 290 (W) × 30 (D) mm 194 (H) × 290 (W) × 75 (D) mm	MW9076J only Including MU250000A
Mass		1.4 kg or less (MW9076J only) 4.0 kg or less (including MU250000A, battery pack)	
Environmental conditions			No condensation
Operating temperature, humidity		-10 to +40 °C, ≤85 %	
Storage temperature, humidity		-20 to +60 °C, ≤85 %	
Vibration		Conforms to MIL-T-28800E Class 3	
Dust-proof		MIL-T-28800E	
Water-proof		MIL-T-28800E	
EMC	Emission	EN 61326-1: 2006 (Class A) EN 61000-3-2: 2006 (Class A equipment)	
	Immunity	EN 61326-1: 2006 (Table 2)	

## Appendix A Specifications

### (6) OTDR main unit (MW9076K)

Item	Standard	Remarks
Model name, unit name	MW9076K GIF 0.85/1.3 μm OTDR	
Wavelength	850/1300 ± 30 nm	At 25 °C Pulse width: 100 ns
Fiber under test	62.5/125 μm multi-mode fiber *2	
Optical connector	<ul style="list-style-type: none"> <li>• FC : Option 37</li> <li>• ST : Option 38</li> <li>• DIN : Option 39</li> <li>• SC : Option 40</li> </ul> PC type	Install one of them  The connectors can be replaced by the user.
Automatic measurement *1		
Measurement items	Total loss and total return loss or Average loss Distance, splice loss, return loss, and reflectance of each event (Table display)	
Threshold value	0.01 to 9.99 dB (0.01 dB increments)	
Splice loss	20 to 60 dB (0.1 dB increment)	
Return loss	1 to 99 dB (1 dB increment)	
Far end of fiber	Up to 99	
Detected events	Distance range, pulse width, number of times of averaging (time)	
Auto setting	Within 60 seconds	At Full Auto measurement
Measurement time	Check the connection status of the light source connector	
Connection check	Check for communication light in the test optical fiber.	
Communication light check		
Manual measurement		
Measurement items	Loss and distance between any two points, loss per unit length between two points, splice loss, return loss or reflectance, total return loss	
Real time sweeping	Sweeping time: 0.1 to 0.2 seconds or less	At Quick mode

\*1 Automatic measurement is a supporting function which enables to operate easier, it doesn't assure results. As there is a case of miss detection, check the waveform as well.

\*2 This specification is defined with the GI fiber of Core diameter:  $62.5 \pm 3 \mu\text{m}$ , NA:  $0.275 \pm 0.015$ , Loss:  $\leq 3.2/0.9$  [dB/km] (Wavelength 0.85/1.3 μm).

When a 50/125 μm optical fiber is used, the dynamic range becomes narrower by approximately 3 dB.

Item	Standard	Remarks
Distance range	1/2.5/5/10/25/50/100 km	IOR = 1.500000
Pulse width	10/20/50/100/500/1000 ns	500 ns, 1 $\mu$ s is only for wavelength 1.3 $\mu$ m
Dynamic range (SNR=1)	21/25 dB	0.85 $\mu$ m at 25 °C Pulse width 100 ns Pulse width 1 $\mu$ s at 1.3 $\mu$ m
Dead zone Back-scattered light	$\leq$ 7/10 m (850 nm/1300 nm)	Pulse width: 10 ns Return loss: 30 dB Deviation: $\pm$ 0.5 dB
Fresnel reflection	$\leq$ 50 m $\leq$ 2 m	Deviation: $\pm$ 0.1 dB Pulse width: 10 ns
Marker resolution	0.05 to 200 m	IOR = 1.500000
Sampling resolution	0.05 to 20 m	IOR = 1.500000
Number of sampling points Quick mode Normal mode High mode	5001 or 6251 20001 or 25001 40001 or 50001	*3
Vertical scale	0.25, 0.5, 1, 2.5, 5, 10, 15 dB/div	15 dB/div is indicated only at Auto and Full Auto measurement
IOR Setting	1.400000 to 1.699999 (0.000001 steps)	
Distance measurement accuracy	$\pm$ 1 m $\pm$ 3 $\times$ measured distance $\pm$ 10 <sup>-5</sup> $\pm$ marker resolution * Uncertainty due to the index of refraction is excluded	
Loss measurement accuracy (linearity)	$\pm$ 0.05 dB/dB or $\pm$ 0.1 dB (whichever the greater)	
Return loss measurement accuracy	$\pm$ 4 dB	
Other functions	<ul style="list-style-type: none"> <li>• Waveform storage: Analysis format, Standard (GR-196-CORE) format, Standard.V2 (SR-4731) format</li> <li>• Printout: Centronics</li> <li>• Continuous measurement: Wavelength switching, waveform storage A series of operations such as print-out can be performed with a single key stroke</li> <li>• Relative distance setting (zero cursor setting)</li> <li>• Waveform comparison</li> <li>• Calendar function</li> <li>• Distance unit setting: m, km, f, kf, mi</li> <li>• Title entry: 32 characters</li> <li>• Battery indication</li> </ul>	

\*3 Either value is automatically selected in each mode, depending on the distance range.

## Appendix A Specifications

Item		Standard	Remarks
Laser safety		21CFRClass 1, IEC Pub60825-1Class 1	
Power supply		Power is supplied from the MU250000A display unit. Refer to the specifications of MU250000A.	
Power consumption		35 W max. (when charged), Standard 4 W	Including MU250000A power consumption
Continuous battery operation		6 h (typical) (CGR-B/802D) 7 h (typical) (CGR-B/802E)	Backlight low, measurement not executed
Dimension		194 (H) × 290 (W) × 30 (D) mm 194 (H) × 290 (W) × 75 (D) mm	MW9076K only Including MU250000A
Mass		1.4 kg or less (MW9076K only) 4.0 kg or less (including MU250000A, battery pack)	
Environmental conditions			No condensation
Operating temperature, humidity		-10 to +40 °C, ≤85 %	
Storage temperature, humidity		-20 to +60 °C, ≤85 %	
Vibration		Conforms to MIL-T-28800E Class 3	
Dust-proof		MIL-T-28800E	
Water-proof		MIL-T-28800E	
EMC	Emission	EN 61326-1: 2006 (Class A) EN 61000-3-2: 2006 (Class A equipment)	
	Immunity	EN 61326-1: 2006 (Table 2)	

## (7) Display unit (MU250000A, MU250000A1, MU250000A4)

Item	Standard	Remarks
Model name, unit name	MU250000A/A1/A4 Display Unit	
Monitor	8.4-inch color TFT-LCD (640 × 480, transmission type, with back light) 7.2-inch color STN-LCD (640 × 480, semi-transmission type, with back light) 7.8-inch color STN-LCD (640 × 480, reflection type, with front light)	MU250000A  MU250000A1  MU250000A4
Interface		
Serial	RS232C-1 (115.2 kbit/s max.), Connector : D-sub 9p RS232C-2 (57.6 kbit/s max.), Connector : Mini DIN 8p	Centronics-compatible
Printer	8-bit parallel interface, Connector : D-sub 25p	
Keyboard	IBM US ENGLISH (101 keys) 106 ready Connector : Mini DIN 6p	
VGA output	Connector : Mini DIN 10p	
Power supply	DC : 10 to 26.4 V AC (Rating) : 100 to 240 V, 50/60 Hz, 50 VA max (When special AC adapter is used) Battery: CGR-B/802D or CGR-B/802E lithium ion battery pack is available (installed in OTDR main unit)	
Power consumption	35 W max.	
Dimension	194 (H) × 290 (W) × 45 (D) mm	
Mass	2.2 kg or less	
Environmental conditions	Subject to limitations of memory card specification when memory card is used and subject to environmental conditions of AC adapter if AC adapter is used.	
Operating temperature, humidity		
When FDD is not operated	-10 to +40 °C, ≤85 %	No condensation
When FDD is operated	+5 to +40 °C, ≤80 %	No condensation
Storage temperature, humidity	-20 to +60 °C, ≤85 %	
Vibration	Conforming to MIL-T-28800E Class 3	
Dust-proof	MIL-T-28800E	
Water-proof	MIL-T-28800E	
EMC		
Emission	EN 61326-1: 2006 (Class A) EN 61000-3-2: 2006 (Class A equipment)	
Immunity	EN 61326-1: 2006 (Table 2)	

## Appendix A Specifications

### (8) Battery pack (CGR-B/802D, CGR-B/802E)

Item	Standard	Remarks
Battery type	Li ion secondary battery	
Voltage, capacity	14.4 V, 2550 mAh (36.72 Wh)	CGR-B/802D
	14.4 V, 3400 mAh (48.96 Wh)	CGR-B/802E
Continuous operation time	Refer to the specifications of the MW9076 OTDR main unit.	
Charging time	3 hours or less	
Dimension	98.5 (H) × 134.5 (W) × 20.5 (D) mm	
Mass	390 g or less	CGR-B/802D
	420 g or less	CGR-B/802E

The battery pack is a consumable item.

### (9) AC adapter

Item	Standard	Remarks
AC nominal input	AC100 to 240 V, 50/60 Hz	
DC nominal input	DC24 V, 2.5 A	
Safety standard	UL, CSA, TÜV/GS, CE, PSE, CB, NORDIC	
Environmental conditions		
Operating temperature, humidity	0 to +40 °C, ≤80 %	
Storage temperature, humidity	−20 to +80 °C, ≤95 %	

### (10) Visible LD (MW9076B/B1/C/D/D1/J/K-01)

Item	Standard	Remarks
Central wavelength	635 ± 15 nm	At 25 °C
Optical output	−3 ± 1.5 dBm	
Output optical fiber	10/125 μm single mode (ITU-T G.652)	
Optical connector	FC/SC/ST/DIN/DIAMOND (HMS-10/A)	Replaceable
Optical safety	IEC Class 1M, 21CFR Class 2	
Environmental conditions	Same as the MW9076 OTDR main unit	

## (11) Optical power meter (MW9076B/B1/C-02)

Item	Standard	Remarks
Applicable optical fiber	10/125 mm single mode (ITU-T G.652)	
Optical connector	FC/SC/ST/DIN/DIAMOND (HMS-10/A)	Replaceable
Wavelength range	1.2 to 1.7 $\mu\text{m}$	
Measurement range	+3 to -70 dBm (Continuous light) 0 to -75 dBm (Modulated light)	
Measurement accuracy	$\pm 5\%$	-10 dBm, Continuous light, 1.31/1.55 $\mu\text{m}$
Environmental conditions	Same as the MW9076 OTDR main unit	

## (12) High input optical power meter (MW9076B/B1/C-03)

Item	Standard	Remarks
Applicable optical fiber	10/125 mm single mode (ITU-T G.652)	
Optical connector	FC/SC/ST/DIN/DIAMOND (HMS-10/A)	Replaceable
Wavelength range	1.2 to 1.7 $\mu\text{m}$	
Measurement range	+23 to -50 dBm (Continuous light) +20 to -55 dBm (Modulated light)	
Measurement accuracy	$\pm 5\%$	-10 dBm, Continuous light, 1.31/1.55 $\mu\text{m}$
Environmental conditions	Same as the MW9076 OTDR main unit	

## (13) Optical channel selector unit (MU960001A, MU960002A)

Item	Standard	Remarks
Configuration	1 $\times$ 4 (MU960001A) 1 $\times$ 8 (MU960002A)	
Wavelength range	1.2 to 1.65 $\mu\text{m}$	
Optical fiber	10/125 $\mu\text{m}$ single mode (ITU-T G.652)	
Optical connector	FC/SC/ST/DIN/DIAMOND (HMS-10/A)	Replaceable
Insertion loss	2.5 dB or less (MU960001A) 4.5 dB or less (MU960002A)	
Environmental conditions	Same as the MW9076 OTDR main unit	
Size	194 (H) $\times$ 290 (W) $\times$ 47 (D) mm	
Mass	1.5 kg or less (MU960001A) 2.0 kg or less (MU960002A)	

## Appendix A Specifications

### (14) Peripherals and parts

Item	Specification	Model name
AC adapter	AC 100 to 240 V 50/60 Hz	Z0695
Car charger	Adapter for the car battery, DC 10 to 15 V	SPC60-3020
Lithium ion battery pack		Z0619
MW9076 Series Operation Manual		W1659AE
MW9076 Series Serial Interface Operation Manual		W1660AE
Printer	Thermal printer, AC100 V, 0 to 40 °C	DPU-414-31B
Thermal Printer	Operates only with AC adapter, printing width 72 mm, printing speed approximately 13 s (manual measurement result with header) , 0 to +40 °C, 119(W)×77(H)×174(D)mm	BL-80R2
AC adapter	For BL-80R2, AC100 to 240 V	BL-100W
CF Card	PC Card adapter is also supplied, 256 MB	ANR-CFX40T256P
Printer connection cable	Centronics-compatible	
FC type adapter		FC-AP
Optical fiber cable with FC-PC at both ends for SM fiber		J0635 □ *1
FDDI-FC conversion cable		J0699 □ *1
FDDI-ST conversion cable		J0700 □ *1
FDDI-SC conversion cable		J0701 □ *1
Soft carrying case	Handbag type (440 W × 310 H × 110 D)	B0442
Soft carrying case	Handbag type (430 W × 300 H × 170 D)	Z0435
Hard carrying case	Main unit, unit and thermal printer can be accommodated.	Z0436
Replaceable FC optical connector		J0617B
Replaceable ST optical connector		J0618D
Replaceable DIN optical connector		J0618E
Replaceable HMS-10/A optical connector		J0618F
Replaceable SC optical connector		J0619B
Serial interface cable	For remote control with IBM-PC or J-3100	J0654A
Serial interface cable	For connecting optical channel selector	J0977
VGA conversion cable	External monitor connecting cable	J0978
Keyboard (PS/2)		Z0321A
Plotting paper	For DPU414 thermal printer (10 rolls/pack)	TP411-28CL
Printer paper	For BL-80R2(10rolls/set)	BL-80-30
Ferrule cleaner		Z0282
Replacement real for ferrule cleaner	For Ferrule cleaner (6pcs/set)	Z0283
Cleaner for optical adapter	Stick type (200/set)	Z0284

**Note:**

\*1 Specify A to C at the □ mark according to the length of the cable.  
(A: 1 m, B: 2 m, C: 3 m)



# Appendix B Least Square Linear Approximation Method

When splice loss is measured, assume two lines, L1 and L2, from the measurement data and obtain the loss as shown in the figure below.

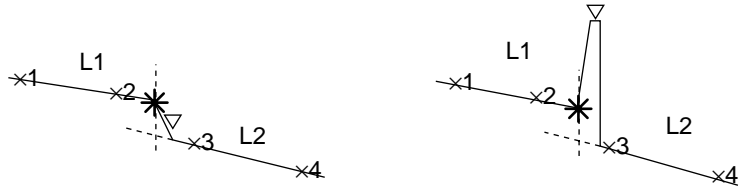

There are two methods for determining these lines: the LSA and 2PA methods. Of these methods, this section explains the LSA (Least Square Approximation) method.

The Least Square Approximation method obtains a straight line such that the variation of distances from all the measurement data points that exist between the markers to the straight line is a minimum.

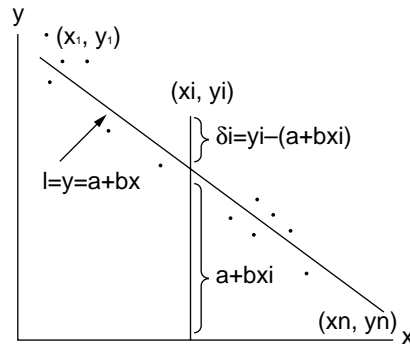

As shown in the figure above, let see this the straight line L from which the variation of distances from n data points  $(x_1, y_1), (x_2, y_2), \dots (x_n, y_n)$  becomes minimum be  $y = a + bx$ . The straight line L is determined by finding the deviation from each point  $(\delta_1, \delta_2, \delta_3, \dots)$  to the straight line L as a value including the variables a and b and finding the variables a and b so that the sum E of the squares of the deviation of points  $\delta_i$  becomes minimum.

$$\delta_i = y_i - (a + bx_i)$$

$$E = \sum_{i=1}^n \delta_i^2 = (y_1 - a - bx_1)^2 + (y_2 - a - bx_2)^2 + \dots + (y_n - a - bx_n)^2$$

In the above equation, the necessary and sufficient condition to minimize E is:

$$\frac{\partial E}{\partial a} = 0, \quad \frac{\partial E}{\partial b} = 0$$

When this equation is solved, the variables a and b can be found as shown below.

$$a = \frac{\bar{y} \sum_{i=1}^n (x_i)^2 - \bar{x} \sum_{i=1}^n (x_i y_i)}{\sum_{i=1}^n (x_i)^2 - n(\bar{x})^2}, \quad b = \frac{\sum_{i=1}^n (x_i y_i) - n\bar{x} \bar{y}}{\sum_{i=1}^n (x_i)^2 - n(\bar{x})^2}$$

$$\text{where, } \bar{x} = \frac{1}{n} \sum_{i=1}^n (x_i), \quad \bar{y} = \frac{1}{n} \sum_{i=1}^n (y_i)$$



# Appendix C Splice Loss Measurement Principle

The trace waveform at the splice point should be displayed as indicated by the dotted line in the figure below, but is actually displayed as indicated by the solid line. The reason why section L is generated is because the waveform inputted to the OTDR shows a sharp falling edge at the splice point so that the circuit cannot respond correctly. Section L increases as the pulse width increases.

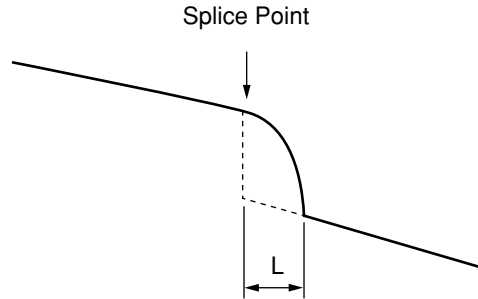

Therefore, the splice loss cannot be measured correctly in the Loss mode. In the Splice & Return Loss mode, two markers are set on each side of the splice point. The splice loss is calculated as shown below.

Draw Lines L1 and L2 as shown below. The part of the straight line immediately after the splice point is the forward projection of straight line L2. The splice loss is found by dropping a perpendicular from the splice point to this projection of L2 and measuring the level difference between the splice point and the intersection.

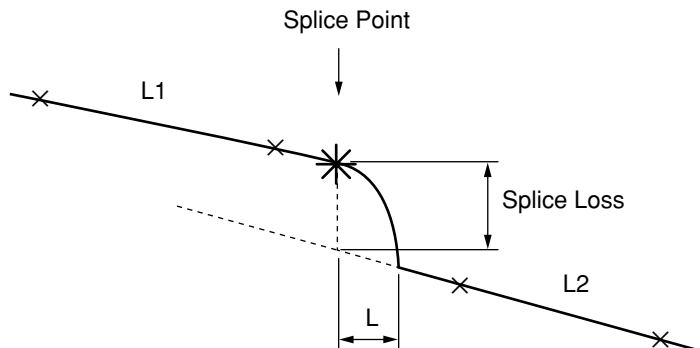



# Appendix D Return Loss Measurement Principle

The return loss R is found from the following equation.

$$R = - (10 \log_{10} \text{bsl} + 10 \log_{10} (10^{L/5} - 1))$$

$$\text{bsl} = S \cdot \alpha_R \cdot V \cdot \frac{W}{2}$$

$$S = K \cdot \frac{N1^2 - N2^2}{N1^2}$$

$$V = \frac{C}{N_e}$$

W (sec): Currently set pulse width

L: Difference of levels between \* and ∇ markers

BSL = 10 log<sub>10</sub>bsl: Back-scattered light level

S: Back-scattered coefficient

α<sub>R</sub>: Rayleigh scattering loss (Np/m)

$$= 0.23026 \times 10^{-3} \times \text{RSL}$$

RSL: Rayleigh scattering loss (dB/km)

V: Group velocity in optical fiber

K: Available constant of optical fiber

N1: Index of refraction of optical fiber core

N2: Index of refraction of optical fiber cladding

N<sub>e</sub>: Effective group index of refraction of optical fiber

C (m/s): Speed of light (3 × 10<sup>8</sup>)



# Appendix E Total Return Loss Measurement Principle

Use the following equation to obtain the total return loss, or TRL, in dB.

$$\begin{aligned} \text{TRL} &= -10\log_{10} \frac{E_R}{E_{in}} \\ &= -10\log_{10} \frac{\int_0^{\infty} P(t) dt}{P_0 W} \\ &= -10\log_{10} \frac{\text{bsl} \int_0^{\infty} P'(t) dt}{W} \quad \text{where, } P'(t) = \frac{P(t)}{P_0 \text{bsl}} \\ &= -10\log_{10} \text{bsl} + 10\log_{10} W - 10\log_{10} \int_0^{\infty} P'(t) dt \end{aligned}$$

$E_R$ : Reflected light energy

$E_{in}$ : Incident light energy

$P(t)$ : OTDR measurement power

$P_0$ : Incident light pulse peak power at  $t = 0$

$W$ : Incident light pulse width

$10\log_{10}\text{bsl}$ : Back-scattered light level

$\int_0^{\infty} P'(t) dt$ : Measured waveform normalized and integrated over the back-scattered light intensity at the incident end

## Reference:

bsl is determined according to the fiber, wavelength, and pulse width. Typical values for 1.3  $\mu\text{m}$  single mode optical fiber are shown below.

Pulse width	Back-scatter level (dB)	
	$\lambda = 1.31 \mu\text{m}$	$\lambda = 1.55 \mu\text{m}$
100 ns	-60	-62.5
1 $\mu\text{s}$	-50	-52.5
10 $\mu\text{s}$	-40	-42.5





# Appendix F Settings at Factory Shipment

The DFN file is factory-set as shown below.

System	OTDR
Channel	None
Measurement mode	Full Auto
Event	Auto Search
Wavelength	1310 nm (MW9076B/B1/C/D/D1) 850 nm (MW9076J/K)
Distance range	Auto
Pulse Width	Auto
Attenuator	Auto (Available OTDR main unit only)
IOR	Depend on OTDR main units
Average Setting item	Auto
Backscatter level	0.00 dB
Sampling data points	QUICK
Sampling resolution	Auto
Sampling range	Full scale
Event threshold	
Splice Loss	0.30 dB
Return Loss	25.0 dB
Fiber end	5.0 dB
Warning On/Off	Off
Warning level	
Splice Loss	0.50 dB
Connection Loss	0.20 dB
Return Loss	25.0 dB
Fiber Loss	0.50 dB/km
Total Loss	20.0 dB
Total Return Loss	25.0 dB
Average Loss	0.50 dB/km
Connection check	OFF
Visible LD	OFF
Communication check	OFF
Title	Anritsu
Header	None
V-Scale	10 dB/div
H-Scale	Full scale
V-Shift	14 dB
H-Shift	0 km
Full View	OFF
Real Time / Average	Average
Event Comment	None
Landmark	None
Optical Switch	None

## Appendix F Settings at Factory Shipment

---

H-Offset	0 km
File Type	Standard
File Compress	Off
Media	INT Memory
Directory	Root
Printer	DPU-414
Print Format Printer	Waveform & Data
Date	On
Date format	Y-M-D
Time	On
Auto power off	15 minutes
Auto backlight off	5 minutes
Sound	On
Distance unit	km

# Appendix G List of Recommended Printers

---

The printers listed below have undergone a performance test by our company.

Seiko Instruments DPU 412

Canon BJC50V and BJC400J

Epson MJ-800C

HP Deskjet 500/500C

Sanei Electric Inc. BL-80R2



# Appendix H Marker Resolution

Distance range [km]	1		2.5		5		10		25					
	5001	20001	5001	25001	5001	25001	5001	20001	5001	25001				
Sampling points	No setting	No setting	Marker resolution [m]											
1	0.2	0.05	0.5	0.1	0.05	1	0.2	0.1	2	0.5	0.2	5	1	0.5
2.5	0.2	0.05	0.5	0.1	0.05	1	0.2	0.1	2	0.5	0.2	5	1	0.5
5	0.2	0.1	0.5	0.1		1	0.2	0.1	2	0.5	0.2	5	1	0.5
10	0.2		0.5	0.2		1	0.2		2	0.5	0.2	5	1	0.5
25	0.5			0.5		1	0.5		2	0.5		5	1	0.5
50	1			1		1			2	1		5	1	
100	2			2		2			2			5		2
250	-			5		5			5			5		5
500	-			-		10			10			10		10
1 k	-			-		-			20			20		20
2.5 k	-			-		-			-			-		50

Distance range [km]	50		100		200		250		400			
	5001	25001	5001	20001	5001	20001	6250	25001	5001	20001		
Sampling points	Marker resolution [m]											
1	10	2	1	20	5	2	40	10	5	40	20	10
2.5	10	2	1	20	5	2	40	10	5	40	20	10
5	10	2	1	20	5	2	40	10	5	40	20	10
10	10	2	1	20	5	2	40	10	5	40	20	10
25	10	2	1	20	5	2	40	10	5	40	20	10
50	10	2	1	20	5	2	40	10	5	40	20	10
100	10	2	1	20	5	2	40	10	5	40	20	10
250	10	5		20	5		40	10	5	40	20	10
500	10	10		20	10		40	10	10	40	20	10
1 k	20	20		20	20		40	20	20	40	20	10
2.5 k	50	50		50	50		40	50	50	40	20	20
5 k	100	100		100	100		40	100	100	80	50	50
10 k	-	-		200	200		40	200	200	80	100	100
20 k	-	-		-	-		400	400	400	80	200	200
25 k	-	-		-	-		-	500	500	80	400	400
40 k	-	-		-	-		-	-	800	80	500	500



# Appendix I Simple OTDR Operation Method

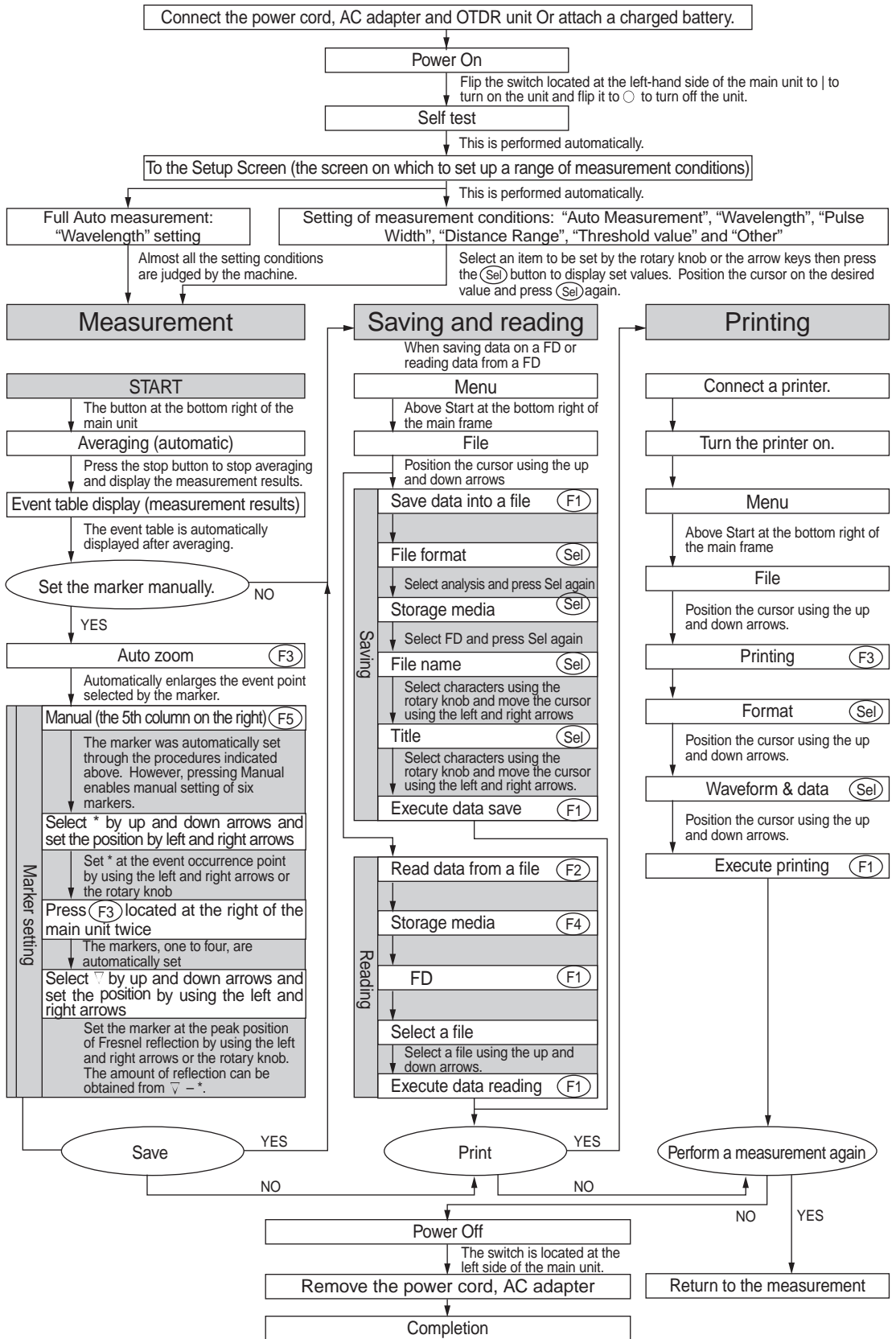

# Appendix I Simple OTDR Operation Method

## Operation for MW9076D/D1 Wavelength Dispersion Measurement (Quick Reference Chart)

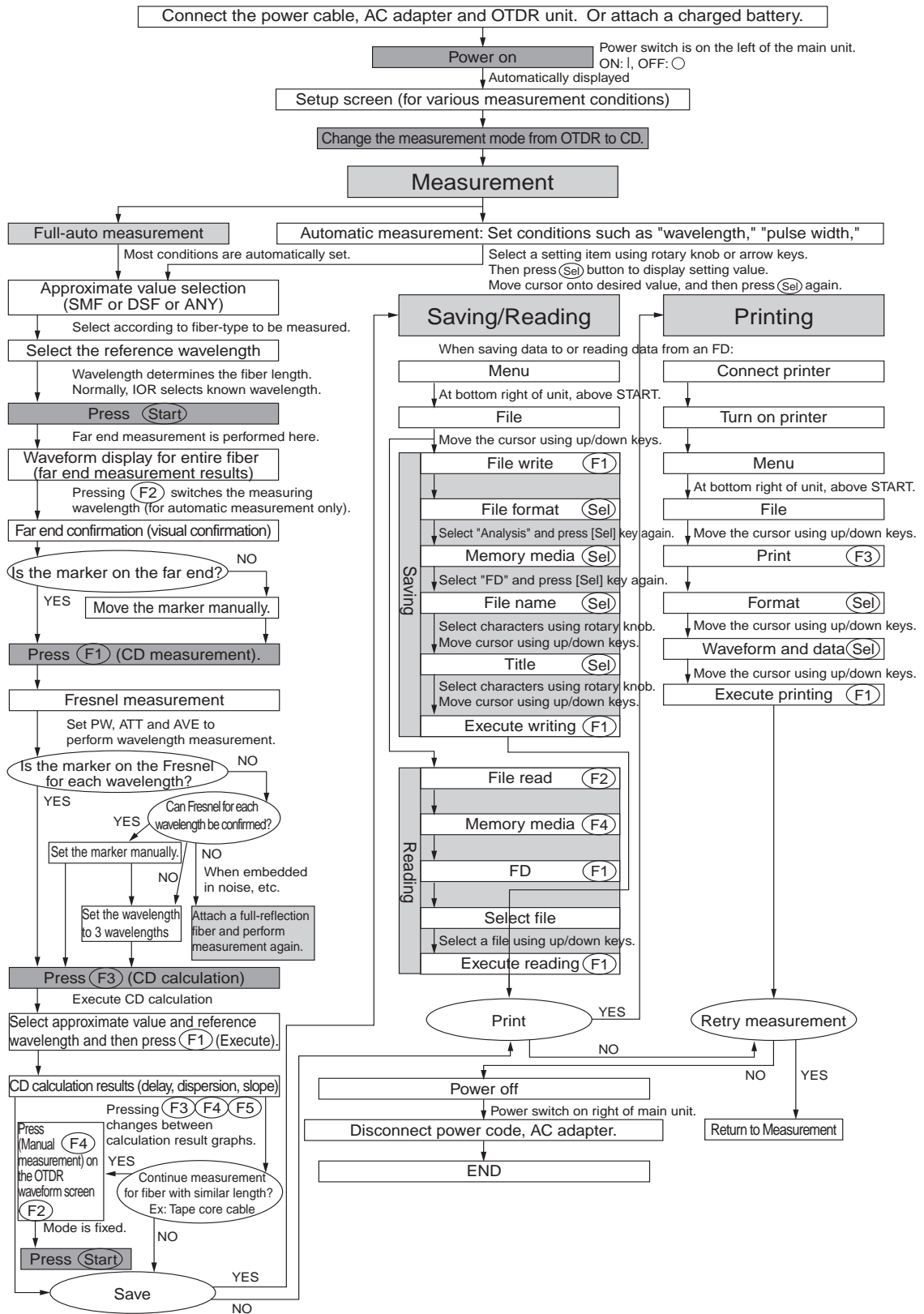



21 CFR 1040.10 .....	v
2PA (Two Point Approximation) Method .....	1-14

## A

Active fiber check .....	3-11
Adding an event .....	4-17
adjustment .....	4-14
Analysis .....	7-9
attenuator .....	3-7, 3-8
Auto .....	3-7
Auto Backlight Off .....	3-17
Auto Increment Function .....	7-25
Auto Mode .....	1-4
Auto power off .....	1-9
Auto Search .....	3-7
Automatic allocation of the marker .....	1-9
automatic waveform save .....	1-9
Average Limit Item .....	3-9
Average Limit Value .....	3-9
Average Number .....	5-6
Averaging .....	1-8

## B

Backscatter level .....	3-9
Battery pack	
Charging the battery pack .....	2-8
Installing the battery pack .....	2-6
Removing the battery pack .....	2-7
Baud rate .....	3-21
Built-in optical channel selector .....	1-11

## C

Cable Code .....	3-14
Cable ID .....	3-14
card .....	2-11
CD .....	3-6
Channel .....	3-6, 5-5
Charging the battery pack .....	2-7
Checking the communication light .....	1-7
Chromatic Dispersion .....	1-10
Cleaning the Floppy Disk Drive .....	9-3
Cleaning the Optical Connector .....	9-2
Comment .....	3-14
Connecting a computer .....	2-22
Connecting a keyboard .....	2-24

Connecting a printer ..... 2-21  
Connecting an external monitor ..... 2-23  
Connecting an optical channel selector ..... 2-17  
Connecting the AC adapter ..... 2-5  
Connecting the Optical Fiber Cable ..... 2-14  
Connecting the Power Supply ..... 2-5  
Connection ..... 3-21  
Connection check ..... 3-11  
Continuous automatic measurement ..... 1-6  
Continuous Printing ..... 7-6  
Copy ..... 7-23  
Cursor Keys ..... 2-9  
Customer ..... 3-14, 3-31

**D**

Data ..... 7-4  
Data bit ..... 3-21  
Data Flag ..... 3-14, 3-31  
Data points ..... 3-10  
Delete ..... 7-13, 7-19  
Deleting an event ..... 4-20  
Difference in time ..... 3-16  
Directory ..... 4-36, 7-11  
display unit ..... 1-2

**E**

Editing the event points ..... 1-8  
Editing the Events ..... 4-16  
emulation mode ..... 7-17  
Entering an event comment ..... 4-22  
Event ..... 3-7  
Event Comment ..... 3-31  
Event Comment On/Off ..... 7-5  
Event registration function ..... 1-8  
Event Table ..... 4-10  
Event Threshold ..... 3-12

**F**

Fiber End ..... 3-12  
Fiber ID ..... 3-14  
Fiber Loss ..... 3-12  
File Compress ..... 4-36  
File Name ..... 4-36  
File name ..... 7-13  
File Type ..... 4-36, 7-9

Fixed .....	3-7
Flow Control .....	3-21
Format .....	3-31
Full Auto .....	3-7
Full Auto Mode .....	1-4
Function Keys .....	2-9

**H**

Header .....	3-14
high resolution .....	1-7
high speed .....	1-7
How to perform an accurate measurement .....	4-28

**I**

Initialize .....	7-22
Inserting and removing a floppy disk .....	2-16
Inserting and removing a memory card .....	2-15
Installing the battery pack .....	2-6
Installing the OTDR main unit .....	2-13
IOR (Index of Reflection) .....	3-9

**L**

Language .....	3-17
Linear approximation method .....	4-27
Log Table .....	4-32
Loss and Total Return Loss .....	1-11
Loss and Total Return Loss Measurement .....	1-11
LSA .....	1-14

**M**

Making high resolution .....	1-7
Manual Mode .....	1-5
Measurement conditions .....	4-10
Measurement mode .....	3-7
Measurement Parameter .....	3-8
Measurement results .....	4-27
Measuring the absolute distance .....	4-48
Measuring the connection loss (connector) .....	4-52
Measuring the connection loss (splice) .....	4-51
Measuring the relative distance .....	4-49
Measuring the return loss .....	4-55
Measuring the transmission loss .....	4-54
Media .....	4-36, 7-10
Menu Key .....	2-9
Method of entering a title .....	3-13

Modulation ..... 5-5  
More ..... 4-13  
Moving an event ..... 4-19  
Moving to the Manual Measurement Screen ..... 4-26

**N**

Nameplate ..... 2-10  
normal speed ..... 1-7

**O**

OLTS (Optical Loss Test Set) measurement ..... 1-10  
OLTS Function ..... 5-2  
Operator ..... 3-14, 3-31  
optical channel selector ..... 1-6  
Optical Loss Measurement ..... 5-13  
Optical Power Meter ..... 1-2  
optical power meter ..... 5-2  
Org Loc ..... 3-14, 3-31  
OTDR main unit ..... 1-2  
Owner ..... 3-14, 3-31

**P**

Parity ..... 3-21  
PCMCIA Drv1 ..... 7-10  
PCMCIA Drv2 ..... 7-10  
Power switch ..... 2-8  
Preview ..... 3-32  
Preview mode ..... 1-6  
Print ..... 4-36, 7-2  
Print Format ..... 7-4  
Printing the Settings ..... 3-26  
Printing the settings ..... 3-30  
Pulse Width ..... 3-8

**R**

Range ..... 3-10  
Range Hold ..... 5-7  
Reading the DFN file ..... 3-26  
Reading the measurement result ..... 4-37  
real-time ..... 1-8  
Recall ..... 7-15  
Reference Level ..... 5-7  
reflectance ..... 3-24  
Reflection Measurement ..... 1-12  
Reflective type ..... 3-24

Registering and researching an event ..... 4-16

Relative Distance Measurement ..... 4-39

Removing the battery pack ..... 2-6

Removing the OTDR Main Unit ..... 2-13

Repeat Channel ..... 4-33

Repeat Task Function ..... 4-30

Repeat Wavelength ..... 4-34

Replacing the Optical Connector ..... 2-12

researching an event ..... 4-21

Resolution ..... 3-10

Return Loss ..... 3-12

Returning to the Event Table screen ..... 4-29

Rotary Knob ..... 2-9

**S**

Sample Information ..... 3-10

Save ..... 7-8

Saving the DFN file ..... 3-28

Search results ..... 4-10

Select CH ..... 3-33

Select Key ..... 2-9

Select 1 ..... 3-33

Select the data to be printed ..... 7-4

Self-Diagnosis ..... 9-4

Setting items ..... 3-2

Setting the color on the screen ..... 3-25

Setting the display on the screen ..... 3-23

Setting the Measurement Conditions ..... 4-4

Setting the optical channel selector ..... 3-22

Setting the printer ..... 3-18

Setting the serial port ..... 3-20

Setting the system ..... 3-15

Setup ..... 7-4

Setup Screens ..... 3-6

Sort ..... 4-37

Sound ..... 3-17

Splice Loss ..... 3-12

Stand ..... 2-10

Standard ..... 7-9

Standard.V2 ..... 7-9

Start Key ..... 2-9

Starting a Measurement ..... 4-9

Status Display Lamp ..... 2-9

Stop bit ..... 3-21

System ..... 3-6, 5-5

**T**

Term Loc ..... 3-14, 3-31  
Time ..... 3-9  
Title ..... 3-13  
Total Loss ..... 3-12  
Total Return Loss ..... 1-11, 3-12  
total return loss ..... 3-9  
Trace waveform ..... 4-11

**V**

Visible LD ..... 1-9, 3-11, 5-6

**W**

Warning Level ..... 3-12  
warning level ..... 1-7  
Waveform & Data ..... 7-4  
Waveform comparison ..... 1-9  
Wavelength ..... 3-8  
Wavelength for Cal ..... 5-6

**Z**

zero cursor ..... 4-39